



065 CATALOGUE



Pinasco[®]
PURE PASSION

**SCOOTER & SCOOTER RACING
YOUNG BIKE
VESPA & VESPA RACING
VESPAMATIC
MOPED**



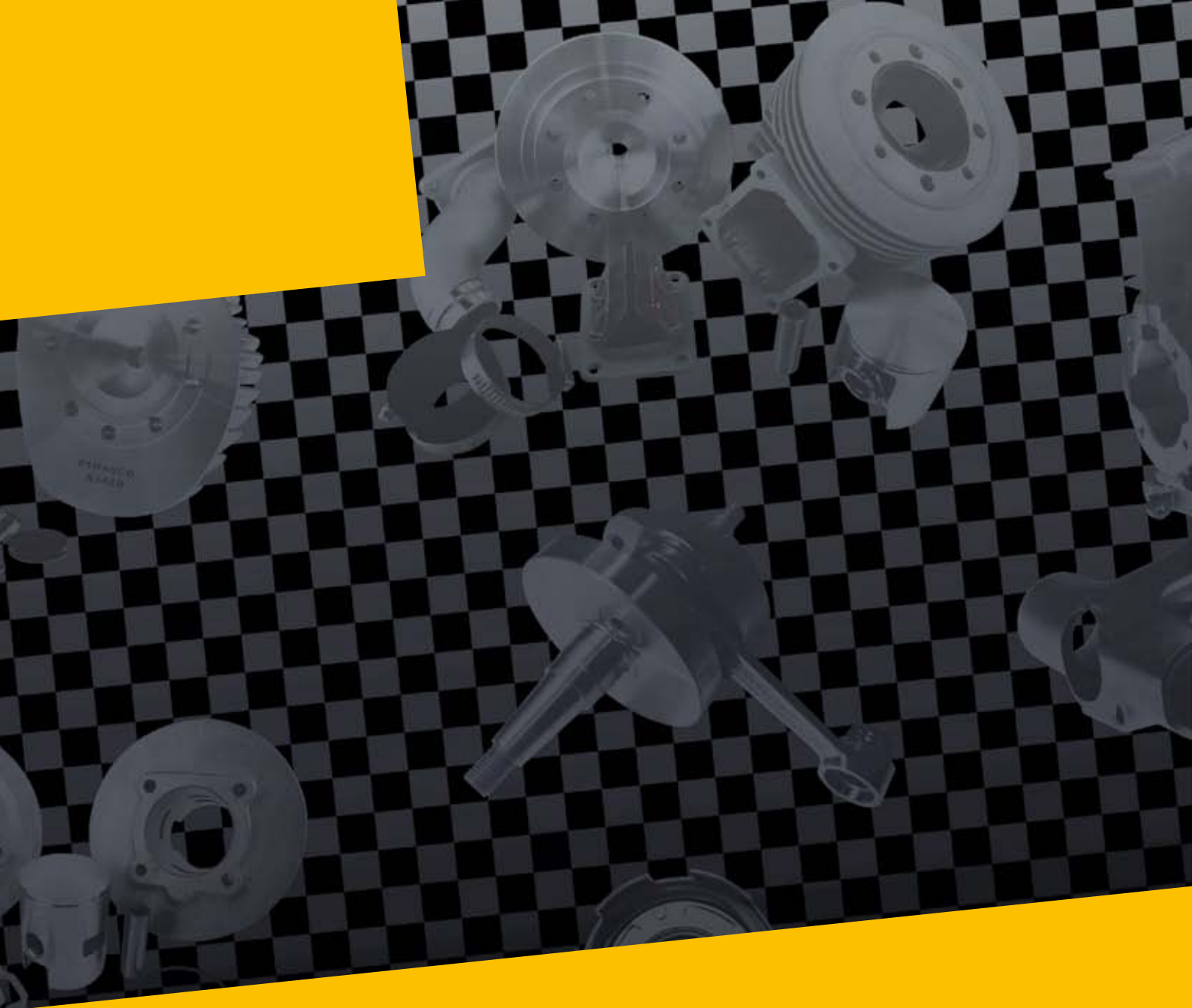

www.pinasco.com

INDICE|INDEX

**SCOOTER &
SCOOTER RACING**

4

YOUNG BIKE

82

VESPA

85

VESPA RACING

125

VESPAMATIC

134

MOPED

142

**CARBURATORI
& RICAMBI**

146

MERCHANDISING

150

Tutte le foto presenti in questo catalogo sono di riferimento.
All photographs are to be considered as reference.

I prodotti Pinasco sono progettati e costruiti per l'impiego agonistico.
L'utilizzo su strada pubblica è vietato.
*Pinasco products are designed and made exclusively for racing purposes.
Use on public road is prohibited.*

Gruppi Termici in Ghisa TForce Cast Iron Cylinder Kits TForce

Cilindro in ghisa perlitica additivata con distribuzione a 5 luci di travaso. Travaseraia concepita per garantire un'erogazione estremamente vigorosa sin dai bassi regimi. Testa di tipo troncoconico con banda di squish calcolata. Pistone in lega di alluminio ad alto tenore di silicio con due segmenti.

Luca di scarico di forma ellittica ad ampia superficie e profilo tale da aumentare la durata dei segmenti. Diagramma studiato per garantire il giusto equilibrio tra coppia ai bassi regimi e potenza massima.

Cast iron cylinder pearlitic additivity with distribution 5 lights racking. The openings designed to ensure supply extremely vigorous since the low revs. Head with a truncated cone squish band calculated.

Alloy piston high standard with two rings. Light exhaust elliptical in shape to large surface and profile that increase the duration of the segments. Diagram designed to ensure the right balance between the pair low revs and maximum power.

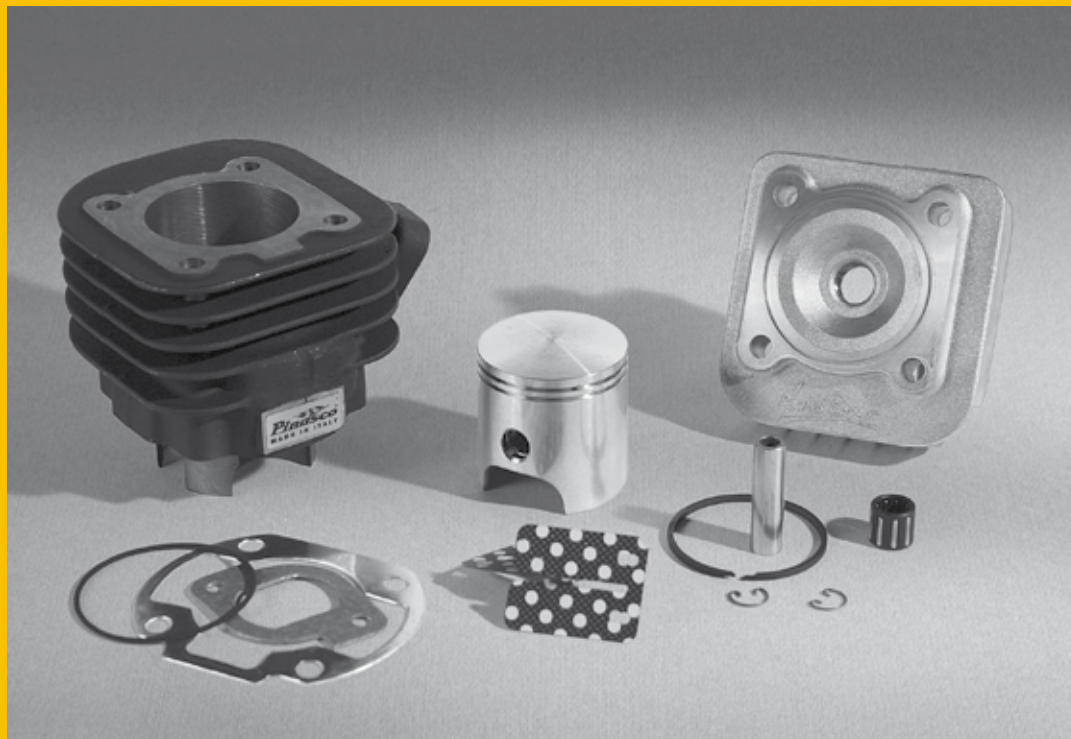

MARCA	MODELLO	Ø	CC	TEMPI	CODICE
BRAND	MODEL	Ø	CC	STROKE	ITEM
APRILIA	Amico *50	47	68	2	10040403
APRILIA	Area 51	47	68	2	10040404
APRILIA	Gulliver *50	47	68	2	10040406
APRILIA	Gulliver *50 LC	47	68	2	10040404
APRILIA	Mojito *50 Custom	47	68	2	10040408
APRILIA	Rally *50	47	68	2	10040406
APRILIA	Rally *50 LC	47	68	2	10040404
APRILIA	Scarabeo *50 2T	47	68	2	10040406
APRILIA	Scarabeo *50 2T Street Carburatore	47	68	2	10040408
APRILIA	Sonic *50	47	68	2	10040406
APRILIA	Sonic *50 LC	47	68	2	10040404
APRILIA	SR *50 <-1993	47	68	2	10040403
APRILIA	SR *50 1994->	47	68	2	10040406
APRILIA	SR *50 2004 / Piaggio Carburatore	47	68	2	10040402
APRILIA	SR *50 DiTech GP1 / Piaggio Iniezione	47	68	2	10040410
APRILIA	SR *50 Netscaper LC	47	68	2	10040404
APRILIA	SR *50 R / Piaggio Carburatore	47	68	2	10040402
APRILIA	SR *50 R Factory	47	68	2	10040410
APRILIA	SR *50 Racing LC	47	68	2	10040404
APRILIA	SR *50 Replica LC	47	68	2	10040404
APRILIA	SR *50 Stealth LC	47	68	2	10040404
APRILIA	SR *50 WWW	47	68	2	10040406
ATALA	Carosello *50	47	68	2	10040406
BENELLI	491 Gt	47	68	2	10040406
BENELLI	491 Sport LC	47	68	2	10040404
BENELLI	K2 *50	47	68	2	10040406

MARCA	MODELLO	Ø	CC	TEMPI	CODICE
BRAND	MODEL	Ø	CC	STROKE	ITEM
BENELLI	K2 *50 LC	47	68	2	10040404
BENELLI	Naked *50	47	68	2	10040406
BENELLI	Pepe *50	47	68	2	10040406
BENELLI	Pepe LX *50 euro 2	47	68	2	10040411
BENELLI	QuattroNove X *50 euro 2	47	68	2	10040411
BETA	Ark *50	47	68	2	10040406
BETA	Ark *50 LC	47	68	2	10040404
BETA	Chrono	47	68	2	10040406
BETA	Eikon *50 LC	47	68	2	10040404
BETA	Quadra	47	68	2	10040406
BETA	Tempo	47	68	2	10040406
BSV	Ax	47	68	2	10040406
BSV	Gz	47	68	2	10040406
CPI	Aragon GP - Hussar - Oliver - Popcorn 2003 >	47	68	2	10040411
CPI	Hussar - Oliver - Popcorn < 2002	47	68	2	10040406
CPI	Aragon GP - Hussar - Oliver - Popcorn > 2003	47	68	2	10040411
DERBI	Atlantis *50	47	68	2	10040408
DERBI	Bullet *50	47	68	2	10040408
DERBI	GP1 *50 LC	47	68	2	10040402
DERBI	GP1 *50 OPEN	47	68	2	10040402
DERBI	GP1 *50 REVOLUTION	47	68	2	10040402
EXPLORER	Cracker *50 2003>	47	68	2	10040411
FANTIC	Big Wheel *50 2T	47	68	2	10040403
GARELLI	Gsp *50	47	68	2	10040404
GARELLI	Pony *50	47	68	2	10040403
GARELLI	Sr *50	47	68	2	10040403
GARELLI	Tiesse *50 R	47	68	2	10040411
GILERA	DNA *50 LC	47	68	2	10040402
GILERA	Easy Moving	47	68	2	10040408
GILERA	Ice *50 2T	47	68	2	10040408
GILERA	Runner *50 LC < 2005	47	68	2	10040402
GILERA	Runner *50 PureJet <-2005	47	68	2	10040410
GILERA	Runner *50 PureJet 2006->	47	68	2	10040410
GILERA	Runner *50 SP LC <-2005	47	68	2	10040402
GILERA	Runner *50 SP LC Carburatore 2006->	47	68	2	10040402
GILERA	Stalker	47	68	2	10040408
GILERA	Storm	47	68	2	10040408
GILERA	Typhoon	47	68	2	10040408
GILERA	Typhoon *50 X	47	68	2	10040408
HUPPER	Montecarlo 30 2T	47	68	2	10040411
ITALJET	Bazooka	47	68	2	10040403
ITALJET	Dragster *50 LC	47	68	2	10040404
ITALJET	Jet Set *50	47	68	2	10040408
ITALJET	Pista	47	68	2	10040403
ITALJET	Pista 2	47	68	2	10040403
ITALJET	Reporter	47	68	2	10040403
ITALJET	Scoop	47	68	2	10040403
ITALJET	Torpedo *50 2T New	47	68	2	10040408
ITALJET	Yankee	47	68	2	10040403
KEEWAY	F-ACT	47	68	2	10040411
KEEWAY	Goccia	47	68	2	10040411
KEEWAY	Hurricane	47	68	2	10040411
KEEWAY	Matrix	47	68	2	10040411
KEEWAY	Pixel	47	68	2	10040411
KEEWAY	RY8	47	68	2	10040411
LEM	Flash *50 2T	47	68	2	10040403
LEM	Ghibli *50 2T	47	68	2	10040403
LEM	Tornado *50 2T	47	68	2	10040403
MALAGUTI	Centro *50 2T	47	68	2	10040406
MALAGUTI	Ciak *50	47	68	2	10040406
MALAGUTI	F10	47	68	2	10040406
MALAGUTI	F10 Wap	47	68	2	10040411
MALAGUTI	F12 Digit KAT 50 LC	47	68	2	10040404
MALAGUTI	F12 Digit KAT 50 LC euro 2	47	68	2	10040404
MALAGUTI	F12 Phantom *50	47	68	2	10040406
MALAGUTI	F12 Phantom *50 LC	47	68	2	10040404
MALAGUTI	F12 R AIR euro 2	47	68	2	10040411
MALAGUTI	F12 R LC euro 2	47	68	2	10040404
MALAGUTI	F15 Firefox LC	47	68	2	10040404
MALAGUTI	Yesterday	47	68	2	10040406

MARCA	MODELLO	Ø	CC	TEMPI	CODICE
BRAND	MODEL	Ø	CC	STROKE	ITEM
MBK	Booster *50 euro 0-1	47	68	2	10040403
MBK	Booster *50 Naked euro 2	47	68	2	10040403
MBK	Booster *50 NG euro 0-1	47	68	2	10040403
MBK	Booster *50 NG euro 2	47	68	2	10040403
MBK	Booster *50 Spirit euro 0-1	47	68	2	10040403
MBK	Evolis	47	68	2	10040406
MBK	Fizz	47	68	2	10040406
MBK	Flipper	47	68	2	10040406
MBK	Forte	47	68	2	10040406
MBK	Hot Champ	47	68	2	10040406
MBK	Mach G 50	47	68	2	10040406
MBK	Mach G 50 LC	47	68	2	10040404
MBK	Nitro *50	47	68	2	10040404
MBK	Ovetto *50	47	68	2	10040406
MBK	Rocket	47	68	2	10040403
MBK	Rocket 50 euro 2	47	68	2	10040403
MBK	Sorriso *50 2T <-1995	47	68	2	10040403
MBK	Sorriso *50 2T 1996->	47	68	2	10040406
MBK	Stunt *50 2T euro 0-1	47	68	2	10040403
MBK	Stunt *50 2T euro 2	47	68	2	10040403
MBK	Target *50 2T	47	68	2	10040403
P.G.O.	Big Max *50 2T	47	68	2	10040406
PIAGGIO	Diesis *50 2T	47	68	2	10040408
PIAGGIO	Fly *50 2T	47	68	2	10040408
PIAGGIO	Free *50 2T	47	68	2	10040408
PIAGGIO	Liberty *50 2T	47	68	2	10040408
PIAGGIO	NRG *50 LC	47	68	2	10040402
PIAGGIO	NRG Extreme	47	68	2	10040408
PIAGGIO	NRG Extreme LC	47	68	2	10040402
PIAGGIO	NRG Mc2 LC <-1997	47	68	2	10040402
PIAGGIO	NRG Mc2 LC 1998->	47	68	2	10040402
PIAGGIO	NRG Mc3 DD LC	47	68	2	10040402
PIAGGIO	NRG Mc3 DT	47	68	2	10040408
PIAGGIO	NRG Mc3 PureJet LC	47	68	2	10040410
PIAGGIO	NRG Power DD LC	47	68	2	10040402
PIAGGIO	NRG Power DT LC	47	68	2	10040408
PIAGGIO	NRG Power PureJet	47	68	2	10040410
PIAGGIO	NTT LC	47	68	2	10040402
PIAGGIO	Quartz LC	47	68	2	10040402
PIAGGIO	Sfera *50	47	68	2	10040408
PIAGGIO	Sfera *50 Rst	47	68	2	10040408
PIAGGIO	Typhoon *50 2T 2007->2010	47	68	2	10040408
PIAGGIO	Typhoon *50 2T euro 2 - 2011->	47	68	2	10040408
PIAGGIO	Zip *50 2T	47	68	2	10040408
PIAGGIO	Zip *50 2T / 2000	47	68	2	10040408
PIAGGIO	Zip Fast Rider	47	68	2	10040408
PIAGGIO	Zip SP LC ->2000	47	68	2	10040402
PIAGGIO	Zip SP LC 2001->	47	68	2	10040402
YAMAHA	Aerox *50 euro 0-1	47	68	2	10040404
YAMAHA	Aerox *50 euro 2	47	68	2	10040404
YAMAHA	Axis *50 2T	47	68	2	10040406
YAMAHA	Breeze *50 2T	47	68	2	10040406
YAMAHA	BW'S *50 euro 0-1	47	68	2	10040403
YAMAHA	BW'S *50 NG euro 0-1	47	68	2	10040403
YAMAHA	BW'S *50 NG euro 2	47	68	2	10040403
YAMAHA	BW'S *50 Original / Naked 2T euro 2 > 2010	47	68	2	10040403
YAMAHA	CRZ *50 2T	47	68	2	10040403
YAMAHA	CT *50 2T	47	68	2	10040403
YAMAHA	Jog *50	47	68	2	10040406
YAMAHA	Jog *50 ER	47	68	2	10040406
YAMAHA	Jog *50 R	47	68	2	10040406
YAMAHA	Jog *50 RR	47	68	2	10040404
YAMAHA	Jog *50 Z	47	68	2	10040406
YAMAHA	Neo's *50 2T	47	68	2	10040406
YAMAHA	Slider *50 2T	47	68	2	10040403
YAMAHA	Spy *50 2T	47	68	2	10040403
YAMAHA	Vino *50 2T	47	68	2	10040406
YAMAHA	Why *50 2T	47	68	2	10040406
YAMAHA	Zest *50 2T	47	68	2	10040406
YAMAHA	Zuma *50 2T	47	68	2	10040403

Gruppi Termici in Ghisa TForce Spinotto Ø 12 Cast Iron Cylinder Kits TForce Piston pin Ø 12

Cilindro in ghisa perlitica additivata con distribuzione a 5 luci di travaso. Travasera concepita per garantire un'erogazione estremamente vigorosa sin dai bassi regimi. Testa di tipo troncoconico con banda di squish calcolata. Pistone in lega di alluminio ad alto tenore di silicio con due segmenti. Luce di scarico di forma ellittica ad ampia superficie e profilo tale da aumentare la durata dei segmenti. Diagramma studiato per garantire il giusto equilibrio tra coppia ai bassi regimi e potenza massima.

Cast iron cylinder pearlitic additivity with distribution 5 lights racking. The openings designed to ensure supply extremely vigorous since the low revs. Head with a truncated cone squish band calculated. Alloy piston high standard with two rings. Light exhaust elliptical in shape to large surface and profile that increase the duration of the segments. Diagram designed to ensure the right balance between the pair low revs and maximum power.



MARCA	MODELLO	Ø	CC	TEMPI	CODICE
BRAND	MODEL	Ø	CC	STROKE	ITEM
APRILIA	Area 51	47	68	2	10040424
APRILIA	Gulliver *50	47	68	2	10040426
APRILIA	Gulliver *50 LC	47	68	2	10040424
APRILIA	Rally *50	47	68	2	10040426
APRILIA	Rally *50 LC	47	68	2	10040424
APRILIA	Scarabeo *50 2T	47	68	2	10040426
APRILIA	Sonic *50	47	68	2	10040426
APRILIA	Sonic *50 LC	47	68	2	10040424
APRILIA	SR *50 1994->	47	68	2	10040426
APRILIA	SR *50 Netscaper LC	47	68	2	10040424
APRILIA	SR *50 Racing LC	47	68	2	10040424
APRILIA	SR *50 Replica LC	47	68	2	10040424
APRILIA	SR *50 Stealth LC	47	68	2	10040424
APRILIA	SR *50 WWW	47	68	2	10040426
ATALA	Carosello *50	47	68	2	10040426
BENELLI	491 Gt	47	68	2	10040426
BENELLI	491 Sport LC	47	68	2	10040424
BENELLI	K2 *50	47	68	2	10040426
BENELLI	K2 *50 LC	47	68	2	10040424
BENELLI	Naked *50	47	68	2	10040426
BENELLI	Pepe *50	47	68	2	10040426
BETA	Ark *50	47	68	2	10040426
BETA	Ark *50 LC	47	68	2	10040424
BETA	Chrono	47	68	2	10040426
BETA	Eikon *50 LC	47	68	2	10040424
BETA	Quadra	47	68	2	10040426
BETA	Tempo	47	68	2	10040426
BSV	Ax	47	68	2	10040426
BSV	Gz	47	68	2	10040426
CPI	Hussar - Oliver - Popcorn < 2002	47	68	2	10040426
GARELLI	Gsp *50	47	68	2	10040424
ITALJET	Dragster *50 LC	47	68	2	10040424
MALAGUTI	Centro *50 2T	47	68	2	10040426

MARCA	MODELLO	Ø	CC	TEMPI	CODICE
BRAND	MODEL	Ø	CC	STROKE	ITEM
MALAGUTI	Ciak *50	47	68	2	10040426
MALAGUTI	F10	47	68	2	10040426
MALAGUTI	F12 Digit KAT 50 LC	47	68	2	10040424
MALAGUTI	F12 Digit KAT 50 LC euro 2	47	68	2	10040424
MALAGUTI	F12 Phantom *50	47	68	2	10040426
MALAGUTI	F12 Phantom *50 LC	47	68	2	10040424
MALAGUTI	F12 R LC euro 2	47	68	2	10040424
MALAGUTI	F15 Firefox LC	47	68	2	10040424
MALAGUTI	Yesterday	47	68	2	10040426
MBK	Evolis	47	68	2	10040426
MBK	Fizz	47	68	2	10040426
MBK	Flipper	47	68	2	10040426
MBK	Forte	47	68	2	10040426
MBK	Hot Champ	47	68	2	10040426
MBK	Mach G 50	47	68	2	10040426
MBK	Mach G 50 LC	47	68	2	10040424
MBK	Nitro *50	47	68	2	10040424
MBK	Ovetto *50	47	68	2	10040426
MBK	Sorriso *50 2T 1996->	47	68	2	10040426
P.G.O.	Big Max *50 2T	47	68	2	10040426
YAMAHA	Aerox *50 euro 0-1	47	68	2	10040424
YAMAHA	Aerox *50 euro 2	47	68	2	10040424
YAMAHA	Axis *50 2T	47	68	2	10040426
YAMAHA	Breeze *50 2T	47	68	2	10040426
YAMAHA	Jog *50	47	68	2	10040426
YAMAHA	Jog *50 ER	47	68	2	10040426
YAMAHA	Jog *50 R	47	68	2	10040426
YAMAHA	Jog *50 RR	47	68	2	10040424
YAMAHA	Jog *50 Z	47	68	2	10040426
YAMAHA	Neo's *50 2T	47	68	2	10040426
YAMAHA	Vino *50 2T	47	68	2	10040426
YAMAHA	Why *50 2T	47	68	2	10040426
YAMAHA	Zest *50 2T	47	68	2	10040426

Gruppi Termici in Ghisa TForce Monofascia Cast Iron Cylinder Kits TForce Single Ring

Cilindro in ghisa perlitica additivata con distribuzione a 5 luci di travaso. Travaseria concepita per garantire un'erogazione estremamente vigorosa sin dai bassi regimi. Testa di tipo troncoconico con banda di squish calcolata. Pistone in lega di alluminio mono fascia ad alto tenore di silicio. Luce di scarico di forma ellittica ad ampia superficie e profilo tale da aumentare la durata dei segmenti. Diagramma studiato per garantire il giusto equilibrio tra coppia ai bassi regimi e potenza massima.

Cast iron cylinder pearlitic additivity with distribution to 5 lights racking. The openings conceived to ensure supply very strong sin from low revs. Head of a kind truncated cone with band squish calculated. Alloy mono-ring piston high standard. Light exhaust form a large elliptical surface and profile to raise length of the rings. Diagram designed to ensure fair balance between torque at low revs and maximum power.



MARCA	MODELLO	Ø	CC	TEMPI	CODICE
BRAND	MODEL	Ø	CC	STROKE	ITEM
APRILIA	Amico *50	47	68	2	10041403
APRILIA	Area 51	47	68	2	10041404
APRILIA	Gulliver *50	47	68	2	10041406
APRILIA	Gulliver *50 LC	47	68	2	10041404
APRILIA	Mojito *50 Custom	47	68	2	10041408
APRILIA	Rally *50	47	68	2	10041406
APRILIA	Rally *50 LC	47	68	2	10041404
APRILIA	Scarabeo *50 2T	47	68	2	10041406
APRILIA	Scarabeo *50 2T Street Carburatore	47	68	2	10041408
APRILIA	Sonic *50	47	68	2	10041406
APRILIA	Sonic *50 LC	47	68	2	10041404
APRILIA	SR *50 <-1993	47	68	2	10041403
APRILIA	SR *50 1994->	47	68	2	10041406
APRILIA	SR *50 2004 / Piaggio Carburatore	47	68	2	10041402
APRILIA	SR *50 Netscaper LC	47	68	2	10041404
APRILIA	SR *50 R / Piaggio Carburatore	47	68	2	10041402
APRILIA	SR *50 Racing LC	47	68	2	10041404
APRILIA	SR *50 Replica LC	47	68	2	10041404
APRILIA	SR *50 Stealth LC	47	68	2	10041404
APRILIA	SR *50 WWW	47	68	2	10041406
ATALA	Carosello *50	47	68	2	10041406

MARCA	MODELLO	Ø	CC	TEMPI	CODICE
BRAND	MODEL	Ø	CC	STROKE	ITEM
BENELLI	491 Gt	47	68	2	10041406
BENELLI	491 Sport LC	47	68	2	10041404
BENELLI	K2 *50	47	68	2	10041406
BENELLI	K2 *50 LC	47	68	2	10041404
BENELLI	Naked *50	47	68	2	10041406
BENELLI	Pepe *50	47	68	2	10041406
BETA	Ark *50	47	68	2	10041406
BETA	Ark *50 LC	47	68	2	10041404
BETA	Chrono	47	68	2	10041406
BETA	Eikon *50 LC	47	68	2	10041404
BETA	Quadra	47	68	2	10041406
BETA	Tempo	47	68	2	10041406
BSV	Ax	47	68	2	10041406
BSV	Gz	47	68	2	10041406
CPI	Aragon GP - Hussar - Oliver - Popcorn 2003 >	47	68	2	10041411
CPI	Hussar - Oliver - Popcorn < 2002	47	68	2	10041406
DERBI	Atlantis *50	47	68	2	10041408
DERBI	Bullet *50	47	68	2	10041408
DERBI	GP1 *50 LC	47	68	2	10041402
DERBI	GP1 *50 OPEN	47	68	2	10041402
DERBI	GP1 *50 REVOLUTION	47	68	2	10041402



MARCA	MODELLO	Ø	CC	TEMPI	CODICE
BRAND	MODEL	Ø	CC	STROKE	ITEM
FANTIC	Big Wheel *50 2T	47	68	2	10041403
GARELLI	Gsp *50	47	68	2	10041404
GARELLI	Pony *50	47	68	2	10041403
GARELLI	Sr *50	47	68	2	10041403
GILERA	DNA *50 LC	47	68	2	10041402
GILERA	Easy Moving	47	68	2	10041408
GILERA	Ice *50 2T	47	68	2	10041408
GILERA	Runner *50 LC < 2005	47	68	2	10041402
GILERA	Runner *50 SP LC <-2005	47	68	2	10041402
GILERA	Runner *50 SP LC Carburatore 2006->	47	68	2	10041402
GILERA	Stalker	47	68	2	10041408
GILERA	Storm	47	68	2	10041408
GILERA	Typhoon	47	68	2	10041408
GILERA	Typhoon *50 X	47	68	2	10041408
ITALJET	Bazooka	47	68	2	10041403
ITALJET	Dragster *50 LC	47	68	2	10041404
ITALJET	Jet Set *50	47	68	2	10041408
ITALJET	Pista	47	68	2	10041403
ITALJET	Pista 2	47	68	2	10041403
ITALJET	Reporter	47	68	2	10041403
ITALJET	Scoop	47	68	2	10041403
ITALJET	Torpedo *50 2T New	47	68	2	10041408
ITALJET	Yankee	47	68	2	10041403
KEEWAY	F-ACT	47	68	2	10041411
KEEWAY	Hurricane	47	68	2	10041411
KEEWAY	Matrix	47	68	2	10041411
LEM	Flash *50 2T	47	68	2	10041403
LEM	Ghibli *50 2T	47	68	2	10041403
LEM	Tornado *50 2T	47	68	2	10041403
MALAGUTI	Centro *50 2T	47	68	2	10041406
MALAGUTI	Ciak *50	47	68	2	10041406
MALAGUTI	F10	47	68	2	10041406
MALAGUTI	F12 Digit KAT 50 LC	47	68	2	10041404
MALAGUTI	F12 Digit KAT 50 LC euro 2	47	68	2	10041404
MALAGUTI	F12 Phantom *50	47	68	2	10041406
MALAGUTI	F12 Phantom *50 LC	47	68	2	10041404
MALAGUTI	F12 R AIR euro 2	47	68	2	10041411
MALAGUTI	F12 R LC euro 2	47	68	2	10041404
MALAGUTI	F15 Firefox LC	47	68	2	10041404
MALAGUTI	Yesterday	47	68	2	10041406
MBK	Booster *50 euro 0-1	47	68	2	10041403
MBK	Booster *50 Naked euro 2	47	68	2	10041403
MBK	Booster *50 NG euro 0-1	47	68	2	10041403
MBK	Booster *50 NG euro 2	47	68	2	10041403
MBK	Booster *50 Spirit euro 0-1	47	68	2	10041403
MBK	Evolis	47	68	2	10041406
MBK	Fizz	47	68	2	10041406
MBK	Flipper	47	68	2	10041406
MBK	Forte	47	68	2	10041406
MBK	Hot Champ	47	68	2	10041406
MBK	Mach G 50	47	68	2	10041406
MBK	Mach G 50 LC	47	68	2	10041404
MBK	Nitro *50	47	68	2	10041404
MBK	Ovetto *50	47	68	2	10041406

MARCA	MODELLO	Ø	CC	TEMPI	CODICE
BRAND	MODEL	Ø	CC	STROKE	ITEM
MBK	Rocket	47	68	2	10041403
MBK	Rocket 50 euro 2	47	68	2	10041403
MBK	Sorriso *50 2T <-1995	47	68	2	10041403
MBK	Sorriso *50 2T 1996->	47	68	2	10041406
MBK	Stunt *50 2T euro 0-1	47	68	2	10041403
MBK	Stunt *50 2T euro 2	47	68	2	10041403
MBK	Target *50 2T	47	68	2	10041403
P.G.O.	Big Max *50 2T	47	68	2	10041406
PIAGGIO	Diesis *50 2T	47	68	2	10041408
PIAGGIO	Fly *50 2T	47	68	2	10041408
PIAGGIO	Free *50 2T	47	68	2	10041408
PIAGGIO	Liberty *50 2T	47	68	2	10041408
PIAGGIO	NRG *50 LC	47	68	2	10041402
PIAGGIO	NRG Extreme	47	68	2	10041408
PIAGGIO	NRG Extreme LC	47	68	2	10041402
PIAGGIO	NRG Mc2 LC <-1997	47	68	2	10041402
PIAGGIO	NRG Mc2 LC 1998->	47	68	2	10041402
PIAGGIO	NRG Mc3 DD LC	47	68	2	10041402
PIAGGIO	NRG Mc3 DT	47	68	2	10041408
PIAGGIO	NRG Power DD LC	47	68	2	10041402
PIAGGIO	NRG Power DT LC	47	68	2	10041408
PIAGGIO	NTT LC	47	68	2	10041402
PIAGGIO	Quartz LC	47	68	2	10041402
PIAGGIO	Sfera *50	47	68	2	10041408
PIAGGIO	Sfera *50 Rst	47	68	2	10041408
PIAGGIO	Typhoon *50 2T 2007->2010	47	68	2	10041408
PIAGGIO	Typhoon *50 2T euro 2 - 2011->	47	68	2	10041408
PIAGGIO	Zip *50 2T	47	68	2	10041408
PIAGGIO	Zip *50 2T / 2000	47	68	2	10041408
PIAGGIO	Zip Fast Rider	47	68	2	10041408
PIAGGIO	Zip SP LC ->2000	47	68	2	10041402
PIAGGIO	Zip SP LC 2001->	47	68	2	10041402
YAMAHA	Aerox *50 euro 0-1	47	68	2	10041404
YAMAHA	Aerox *50 euro 2	47	68	2	10041404
YAMAHA	Axis *50 2T	47	68	2	10041406
YAMAHA	Breeze *50 2T	47	68	2	10041406
YAMAHA	BW'S *50 euro 0-1	47	68	2	10041403
YAMAHA	BW'S *50 NG euro 0-1	47	68	2	10041403
YAMAHA	BW'S *50 NG euro 2	47	68	2	10041403
YAMAHA	BW'S *50 Original / Naked 2T euro 2 > 2010	47	68	2	10041403
YAMAHA	CRZ *50 2T	47	68	2	10041403
YAMAHA	CT *50 2T	47	68	2	10041403
YAMAHA	Jog *50	47	68	2	10041406
YAMAHA	Jog *50 ER	47	68	2	10041406
YAMAHA	Jog *50 R	47	68	2	10041406
YAMAHA	Jog *50 RR	47	68	2	10041404
YAMAHA	Jog *50 Z	47	68	2	10041406
YAMAHA	Neo's *50 2T	47	68	2	10041406
YAMAHA	Slider *50 2T	47	68	2	10041403
YAMAHA	Spy *50 2T	47	68	2	10041403
YAMAHA	Vino *50 2T	47	68	2	10041406
YAMAHA	Why *50 2T	47	68	2	10041406
YAMAHA	Zest *50 2T	47	68	2	10041406
YAMAHA	Zuma *50 2T	47	68	2	10041403

Gruppi Termici in Ghisa TForce Spinotto Ø 12 Monofascia Cast Iron Cylinder Kits TForce Piston pin Ø 12 Single Ring

Cilindro in ghisa perlitica additivata con distribuzione a 5 luci di travaso. Travaseraia concepita per garantire un'erogazione estremamente vigorosa sin dai bassi regimi. Testa di tipo troncoconico con banda di squish calcolata. Pistone in lega di alluminio mono fascia ad alto tenore di silicio. Luce di scarico di forma ellittica ad ampia superficie e profilo tale da aumentare la durata dei segmenti. Diagramma studiato per garantire il giusto equilibrio tra coppia ai bassi regimi e potenza massima.

Cast iron cylinder pearlitic additivity with distribution to 5 lights racking. The openings conceived to ensure supply very strong sin from low revs. Head of a kind truncated cone with band squish calculated. Alloy mono-ring piston high standard. Light exhaust form a large elliptical surface and profile to raise length of the rings. Diagram designed to ensure fair balance between torque at low revs and maximum power.



MARCA	MODELLO	Ø	CC	TEMPI	CODICE
BRAND	MODEL	Ø	CC	STROKE	ITEM
APRILIA	Area 51	47	68	2	10041424
APRILIA	Gulliver *50	47	68	2	10041426
APRILIA	Gulliver *50 LC	47	68	2	10041424
APRILIA	Rally *50	47	68	2	10041426
APRILIA	Rally *50 LC	47	68	2	10041424
APRILIA	Scarabeo *50 2T	47	68	2	10041426
APRILIA	Sonic *50	47	68	2	10041426
APRILIA	Sonic *50 LC	47	68	2	10041424
APRILIA	SR *50 1994->	47	68	2	10041426
APRILIA	SR *50 Netscaper LC	47	68	2	10041424
APRILIA	SR *50 Racing LC	47	68	2	10041424
APRILIA	SR *50 Replica LC	47	68	2	10041424
APRILIA	SR *50 Stealth LC	47	68	2	10041424
APRILIA	SR *50 WWW	47	68	2	10041426
ATALA	Carosello *50	47	68	2	10041426
BENELLI	491 Gt	47	68	2	10041426
BENELLI	491 Sport LC	47	68	2	10041424
BENELLI	K2 *50	47	68	2	10041426
BENELLI	K2 *50 LC	47	68	2	10041424
BENELLI	Naked *50	47	68	2	10041426
BENELLI	Pepe *50	47	68	2	10041426
BETA	Ark *50	47	68	2	10041426
BETA	Ark *50 LC	47	68	2	10041424
BETA	Chrono	47	68	2	10041426
BETA	Eikon *50 LC	47	68	2	10041424
BETA	Quadra	47	68	2	10041426
BETA	Tempo	47	68	2	10041426
BSV	Ax	47	68	2	10041426
BSV	Gz	47	68	2	10041426
CPI	Hussar - Oliver - Popcorn < 2002	47	68	2	10041426
GARELLI	Gsp *50	47	68	2	10041424
ITALJET	Dragster *50 LC	47	68	2	10041424
MALAGUTI	Centro *50 2T	47	68	2	10041426

MARCA	MODELLO	Ø	CC	TEMPI	CODICE
BRAND	MODEL	Ø	CC	STROKE	ITEM
MALAGUTI	Ciak *50	47	68	2	10041426
MALAGUTI	F10	47	68	2	10041426
MALAGUTI	F12 Digit KAT 50 LC	47	68	2	10041424
MALAGUTI	F12 Digit KAT 50 LC euro 2	47	68	2	10041424
MALAGUTI	F12 Phantom *50	47	68	2	10041426
MALAGUTI	F12 Phantom *50 LC	47	68	2	10041424
MALAGUTI	F12 R LC euro 2	47	68	2	10041424
MALAGUTI	F15 Firefox LC	47	68	2	10041424
MALAGUTI	Yesterday	47	68	2	10041426
MBK	Evolis	47	68	2	10041426
MBK	Fizz	47	68	2	10041426
MBK	Flipper	47	68	2	10041426
MBK	Forte	47	68	2	10041426
MBK	Hot Champ	47	68	2	10041426
MBK	Mach G 50	47	68	2	10041426
MBK	Mach G 50 LC	47	68	2	10041424
MBK	Nitro *50	47	68	2	10041424
MBK	Ovetto *50	47	68	2	10041426
MBK	Sorriso *50 2T 1996->	47	68	2	10041426
P.G.O.	Big Max *50 2T	47	68	2	10041426
YAMAHA	Aerox *50 euro 0-1	47	68	2	10041424
YAMAHA	Aerox *50 euro 2	47	68	2	10041424
YAMAHA	Axis *50 2T	47	68	2	10041426
YAMAHA	Breeze *50 2T	47	68	2	10041426
YAMAHA	Jog *50	47	68	2	10041426
YAMAHA	Jog *50 ER	47	68	2	10041426
YAMAHA	Jog *50 R	47	68	2	10041426
YAMAHA	Jog *50 RR	47	68	2	10041424
YAMAHA	Jog *50 Z	47	68	2	10041426
YAMAHA	Neo's *50 2T	47	68	2	10041426
YAMAHA	Vino *50 2T	47	68	2	10041426
YAMAHA	Why *50 2T	47	68	2	10041426
YAMAHA	Zest *50 2T	47	68	2	10041426

Gruppi Termici in Alluminio GForce Aluminum Cylinder Kits GForce

Realizzati in alluminio con riporto galvanico, sono caratterizzati da un diagramma di distribuzione ed una conformazione delle luci tali da garantire un compromesso ideale tra coppia e potenza massima erogate. Le teste sono state sviluppate per l'uso di benzina senza piombo. I pistoni sono a due segmenti per un'affidabilità totale.

Made from aluminium with galvanized coating, the thermal units have a distribution diagram and conformation of the openings that provide the ideal compromise between the torque and maximum power supplied. The heads have been developed for use with unleaded petrol. The pistons are made in two segments to give complete reliability.



MARCA	MODELLO	Ø	CC	TEMPI	CODICE
BRAND	MODEL	Ø	CC	STROKE	ITEM
APRILIA	Amico *50	47	68	2	10059903
APRILIA	Area 51	47	68	2	10059904
APRILIA	Gulliver *50	47	68	2	10059906
APRILIA	Gulliver *50 LC	47	68	2	10059904
APRILIA	Habana *50	47	68	2	10059905
APRILIA	Mojito *50	47	68	2	10059905
APRILIA	Mojito *50 Custom	47	68	2	10059908
APRILIA	Rally *50	47	68	2	10059906
APRILIA	Rally *50 LC	47	68	2	10059904
APRILIA	Scarabeo *50 2T	47	68	2	10059906
APRILIA	Scarabeo *50 2T Street Carburatore	47	68	2	10059908
APRILIA	Sonic *50	47	68	2	10059906
APRILIA	Sonic *50 LC	47	68	2	10059904
APRILIA	SR *50 <-1993	47	68	2	10059903
APRILIA	SR *50 1994->	47	68	2	10059906
APRILIA	SR *50 2004 / Piaggio Carburatore	47	68	2	10059902
APRILIA	SR *50 Netscaper LC	47	68	2	10059904
APRILIA	SR *50 R / Piaggio Carburatore	47	68	2	10059902
APRILIA	SR *50 Racing LC	47	68	2	10059904
APRILIA	SR *50 Replica LC	47	68	2	10059904
APRILIA	SR *50 Replica LC 2000 / Aprilia	47	68	2	10059907

MARCA	MODELLO	Ø	CC	TEMPI	CODICE
BRAND	MODEL	Ø	CC	STROKE	ITEM
APRILIA	SR *50 Stealth LC	47	68	2	10059904
APRILIA	SR *50 WWW	47	68	2	10059906
ATALA	Carosello *50	47	68	2	10059906
ATALA	Hacker *50	47	68	2	10059905
BENELLI	491 Gt	47	68	2	10059906
BENELLI	491 Sport LC	47	68	2	10059904
BENELLI	K2 *50	47	68	2	10059906
BENELLI	K2 *50 LC	47	68	2	10059904
BENELLI	Naked *50	47	68	2	10059906
BENELLI	Pepe *50	47	68	2	10059906
BETA	Ark *50	47	68	2	10059906
BETA	Ark *50 LC	47	68	2	10059904
BETA	Chrono	47	68	2	10059906
BETA	Eikon *50 LC	47	68	2	10059904
BETA	Quadra	47	68	2	10059906
BETA	Tempo	47	68	2	10059906
BSV	Ax	47	68	2	10059906
BSV	Gz	47	68	2	10059906
CPI	Hussar - Oliver - Popcorn < 2002	47	68	2	10059906
DERBI	Atlantis *50	47	68	2	10059908
DERBI	Bullet *50	47	68	2	10059908

MARCA	MODELLO	Ø	CC	TEMPI	CODICE
BRAND	MODEL	Ø	CC	STROKE	ITEM
DERBI	GP1 *50 LC	47	68	2	10059902
DERBI	GP1 *50 OPEN	47	68	2	10059902
DERBI	GP1 *50 REVOLUTION	47	68	2	10059902
FANTIC	Big Wheel *50 2T	47	68	2	10059903
GARELLI	Gsp *50	47	68	2	10059904
GARELLI	Pony *50	47	68	2	10059903
GARELLI	Sr *50	47	68	2	10059903
GILERA	DNA *50 LC	47	68	2	10059902
GILERA	Easy Moving	47	68	2	10059908
GILERA	Ice *50 2T	47	68	2	10059908
GILERA	Runner *50 LC < 2005	47	68	2	10059902
GILERA	Runner *50 SP LC <-2005	47	68	2	10059902
GILERA	Runner *50 SP LC Carburatore 2006->	47	68	2	10059902
GILERA	Stalker	47	68	2	10059908
GILERA	Storm	47	68	2	10059908
GILERA	Typhoon	47	68	2	10059908
GILERA	Typhoon *50 X	47	68	2	10059908
ITALJET	Bazooka	47	68	2	10059903
ITALJET	Dragster *50 LC	47	68	2	10059904
ITALJET	Formula *50	47	68	2	10059905
ITALJET	Jet Set *50	47	68	2	10059908
ITALJET	Pista	47	68	2	10059903
ITALJET	Pista 2	47	68	2	10059903
ITALJET	Reporter	47	68	2	10059903
ITALJET	Scoop	47	68	2	10059903
ITALJET	Torpedo *50 2T	47	68	2	10059905
ITALJET	Torpedo *50 2T New	47	68	2	10059908
ITALJET	Velocifero	47	68	2	10059905
ITALJET	Yankee	47	68	2	10059903
LEM	Flash *50 2T	47	68	2	10059903
LEM	Ghibli *50 2T	47	68	2	10059903
LEM	Tornado *50 2T	47	68	2	10059903
MALAGUTI	Centro *50 2T	47	68	2	10059906
MALAGUTI	Ciak *50	47	68	2	10059906
MALAGUTI	Crosser CR1	47	68	2	10059905
MALAGUTI	F10	47	68	2	10059906
MALAGUTI	F12 Digit KAT 50 LC	47	68	2	10059904
MALAGUTI	F12 Digit KAT 50 LC euro 2	47	68	2	10059904
MALAGUTI	F12 Phantom *50	47	68	2	10059906
MALAGUTI	F12 Phantom *50 LC	47	68	2	10059904
MALAGUTI	F12 R LC euro 2	47	68	2	10059904
MALAGUTI	F15 Firefox LC	47	68	2	10059904
MALAGUTI	Yesterday	47	68	2	10059906
MBK	Booster *50 euro 0-1	47	68	2	10059903
MBK	Booster *50 Naked euro 2	47	68	2	10059903
MBK	Booster *50 NG euro 0-1	47	68	2	10059903
MBK	Booster *50 NG euro 2	47	68	2	10059903
MBK	Booster *50 Spirit euro 0-1	47	68	2	10059903
MBK	Evolis	47	68	2	10059906
MBK	Fizz	47	68	2	10059906
MBK	Flipper	47	68	2	10059906
MBK	Forte	47	68	2	10059906
MBK	Hot Champ	47	68	2	10059906
MBK	Mach G 50	47	68	2	10059906
MBK	Mach G 50 LC	47	68	2	10059904
MBK	Nitro *50	47	68	2	10059904
MBK	Ovetto *50	47	68	2	10059906
MBK	Rocket	47	68	2	10059903
MBK	Rocket 50 euro 2	47	68	2	10059903
MBK	Sorriso *50 2T <-1995	47	68	2	10059903
MBK	Sorriso *50 2T 1996->	47	68	2	10059906
MBK	Stunt *50 2T euro 0-1	47	68	2	10059903

MARCA	MODELLO	Ø	CC	TEMPI	CODICE
BRAND	MODEL	Ø	CC	STROKE	ITEM
MBK	Stunt *50 2T euro 2	47	68	2	10059903
MBK	Target *50 2T	47	68	2	10059903
MBK	Thunder 125	47	68	2	10059903
P.G.O.	Big Max *50 2T	47	68	2	10059906
PIAGGIO	Diesis *50 2T	47	68	2	10059908
PIAGGIO	Fly *50 2T	47	68	2	10059908
PIAGGIO	Free *50 2T	47	68	2	10059908
PIAGGIO	Liberty *50 2T	47	68	2	10059908
PIAGGIO	NRG *50 LC	47	68	2	10059902
PIAGGIO	NRG Extreme	47	68	2	10059908
PIAGGIO	NRG Extreme LC	47	68	2	10059902
PIAGGIO	NRG Mc2 LC <-1997	47	68	2	10059902
PIAGGIO	NRG Mc2 LC 1998->	47	68	2	10059902
PIAGGIO	NRG Mc3 DD LC	47	68	2	10059902
PIAGGIO	NRG Mc3 DT	47	68	2	10059908
PIAGGIO	NRG Power DD LC	47	68	2	10059902
PIAGGIO	NRG Power DT LC	47	68	2	10059908
PIAGGIO	NTT LC	47	68	2	10059902
PIAGGIO	Quartz LC	47	68	2	10059902
PIAGGIO	Sfera *50	47	68	2	10059908
PIAGGIO	Sfera *50 Rst	47	68	2	10059908
PIAGGIO	Typhoon *50 2T 2007->2010	47	68	2	10059908
PIAGGIO	Typhoon *50 2T euro 2 - 2011->	47	68	2	10059908
PIAGGIO	Zip *50 2T	47	68	2	10059908
PIAGGIO	Zip *50 2T / 2000	47	68	2	10059908
PIAGGIO	Zip Fast Rider	47	68	2	10059908
PIAGGIO	Zip SP LC ->2000	47	68	2	10059902
PIAGGIO	Zip SP LC 2001->	47	68	2	10059902
RIZZATO	Vamos	47	68	2	10059905
SUZUKI	Address Ah 50 2T	47	68	2	10059905
SUZUKI	AP *50 2T	47	68	2	10059905
SUZUKI	Estilete - UF 50 2T	47	68	2	10059905
SUZUKI	Katana *50 - 1999->	47	68	2	10059905
SUZUKI	Katana *50 <-1998	47	68	2	10059905
SUZUKI	Katana *50 LC <-1998	47	68	2	10059907
SUZUKI	Katana *50 LC 1999->	47	68	2	10059907
SUZUKI	Sepia *50 2T	47	68	2	10059905
SUZUKI	Sepia *50 ZZ 2T	47	68	2	10059905
SUZUKI	Street Magic	47	68	2	10059905
SUZUKI	Zillion *50 2T	47	68	2	10059907
YAMAHA	Aerox *50 euro 0-1	47	68	2	10059904
YAMAHA	Aerox *50 euro 2	47	68	2	10059904
YAMAHA	Axis *50 2T	47	68	2	10059906
YAMAHA	Breeze *50 2T	47	68	2	10059906
YAMAHA	BW'S *50 euro 0-1	47	68	2	10059903
YAMAHA	BW'S *50 NG euro 0-1	47	68	2	10059903
YAMAHA	BW'S *50 NG euro 2	47	68	2	10059903
YAMAHA	BW'S *50 Original / Naked 2T euro 2 > 2010	47	68	2	10059903
YAMAHA	CRZ *50 2T	47	68	2	10059903
YAMAHA	CT *50 2T	47	68	2	10059903
YAMAHA	Jog *50	47	68	2	10059906
YAMAHA	Jog *50 ER	47	68	2	10059906
YAMAHA	Jog *50 R	47	68	2	10059906
YAMAHA	Jog *50 RR	47	68	2	10059904
YAMAHA	Jog *50 Z	47	68	2	10059906
YAMAHA	Neo's *50 2T	47	68	2	10059906
YAMAHA	Slider *50 2T	47	68	2	10059903
YAMAHA	Spy *50 2T	47	68	2	10059903
YAMAHA	Vino *50 2T	47	68	2	10059906
YAMAHA	Why *50 2T	47	68	2	10059906
YAMAHA	Zest *50 2T	47	68	2	10059906
YAMAHA	Zuma *50 2T	47	68	2	10059903

Gruppi Termici in Alluminio GForce Spinotto Ø 12 Aluminum Cylinder Kits GForce Piston pin Ø 12

Realizzati in alluminio con riporto galvanico, sono caratterizzati da un diagramma di distribuzione ed una conformazione delle luci tali da garantire un compromesso ideale tra coppia e potenza massima erogate. Le teste sono state sviluppate per l'uso di benzina senza piombo. I pistoni sono a due segmenti per un'affidabilità totale.

Made from aluminium with galvanized coating, the thermal units have a distribution diagram and conformation of the openings that provide the ideal compromise between the torque and maximum power supplied. The heads have been developed for use with unleaded petrol. The pistons are made in two segments to give complete reliability.



MARCA	MODELLO	Ø	CC	TEMPI	CODICE
BRAND	MODEL	Ø	CC	STROKE	ITEM
APRILIA	Area 51	47	68	2	10059924
APRILIA	Gulliver *50	47	68	2	10059926
APRILIA	Gulliver *50 LC	47	68	2	10059924
APRILIA	Rally *50	47	68	2	10059926
APRILIA	Rally *50 LC	47	68	2	10059924
APRILIA	Scarabeo *50 2T	47	68	2	10059926
APRILIA	Sonic *50	47	68	2	10059926
APRILIA	Sonic *50 LC	47	68	2	10059924
APRILIA	SR *50 1994->	47	68	2	10059926
APRILIA	SR *50 Netscaper LC	47	68	2	10059924
APRILIA	SR *50 Racing LC	47	68	2	10059924
APRILIA	SR *50 Replica LC	47	68	2	10059924
APRILIA	SR *50 Stealth LC	47	68	2	10059924
APRILIA	SR *50 WWW	47	68	2	10059926
ATALA	Carosello *50	47	68	2	10059926
BENELLI	491 Gt	47	68	2	10059926
BENELLI	491 Sport LC	47	68	2	10059924
BENELLI	K2 *50	47	68	2	10059926
BENELLI	K2 *50 LC	47	68	2	10059924
BENELLI	Naked *50	47	68	2	10059926
BENELLI	Pepe *50	47	68	2	10059926
BETA	Ark *50	47	68	2	10059926
BETA	Ark *50 LC	47	68	2	10059924
BETA	Chrono	47	68	2	10059926
BETA	Eikon *50 LC	47	68	2	10059924
BETA	Quadra	47	68	2	10059926
BETA	Tempo	47	68	2	10059926
BSV	Ax	47	68	2	10059926
BSV	Gz	47	68	2	10059926
CPI	Hussar - Oliver - Popcorn < 2002	47	68	2	10059926
GARELLI	Gsp *50	47	68	2	10059924
ITALJET	Dragster *50 LC	47	68	2	10059924
MALAGUTI	Centro *50 2T	47	68	2	10059926

MARCA	MODELLO	Ø	CC	TEMPI	CODICE
BRAND	MODEL	Ø	CC	STROKE	ITEM
MALAGUTI	Ciak *50	47	68	2	10059926
MALAGUTI	F10	47	68	2	10059925
MALAGUTI	F12 Digit KAT 50 LC	47	68	2	10059924
MALAGUTI	F12 Digit KAT 50 LC euro 2	47	68	2	10059924
MALAGUTI	F12 Phantom *50	47	68	2	10059926
MALAGUTI	F12 Phantom *50 LC	47	68	2	10059924
MALAGUTI	F12 R LC euro 2	47	68	2	10059924
MALAGUTI	F15 Firefox LC	47	68	2	10059924
MALAGUTI	Yesterday	47	68	2	10059926
MBK	Evolis	47	68	2	10059926
MBK	Fizz	47	68	2	10059926
MBK	Flipper	47	68	2	10059926
MBK	Forte	47	68	2	10059926
MBK	Hot Champ	47	68	2	10059926
MBK	Mach G 50	47	68	2	10059926
MBK	Mach G 50 LC	47	68	2	10059924
MBK	Nitro *50	47	68	2	10059924
MBK	Ovetto *50	47	68	2	10059926
MBK	Sorriso *50 2T 1996->	47	68	2	10059926
P.G.O.	Big Max *50 2T	47	68	2	10059926
YAMAHA	Aerox *50 euro 0-1	47	68	2	10059924
YAMAHA	Aerox *50 euro 2	47	68	2	10059924
YAMAHA	Axis *50 2T	47	68	2	10059926
YAMAHA	Breeze *50 2T	47	68	2	10059926
YAMAHA	Jog *50	47	68	2	10059926
YAMAHA	Jog *50 ER	47	68	2	10059926
YAMAHA	Jog *50 R	47	68	2	10059926
YAMAHA	Jog *50 RR	47	68	2	10059924
YAMAHA	Jog *50 Z	47	68	2	10059926
YAMAHA	Neo's *50 2T	47	68	2	10059926
YAMAHA	Vino *50 2T	47	68	2	10059926
YAMAHA	Why *50 2T	47	68	2	10059926
YAMAHA	Zest *50 2T	47	68	2	10059926

Gruppi Termici in Alluminio GForce Monofascia Aluminum Cylinder Kits GForce Single Ring

Realizzati in alluminio con riporto galvanico, sono caratterizzati da un diagramma di distribuzione ed una conformazione delle luci tali da garantire un compromesso ideale tra coppia e potenza massima erogate. Le teste sono state sviluppate per l'uso di benzina senza piombo. I pistoni sono ad 1 segmento per garantire il massimo delle prestazioni.

Made from aluminium with galvanized coating, the thermal units have a distribution diagram and conformation of the openings that provide the ideal compromise between the torque and maximum power supplied. The heads have been developed for use with unleaded petrol. The pistons are made in one segment to allow maximum performances.



MARCA	MODELLO	Ø	CC	TEMPI	CODICE
BRAND	MODEL	Ø	CC	STROKE	ITEM
APRILIA	Amico *50	47	68	2	10051903
APRILIA	Area 51	47	68	2	10051904
APRILIA	Gulliver *50	47	68	2	10051906
APRILIA	Gulliver *50 LC	47	68	2	10051904
APRILIA	Rally *50	47	68	2	10051906
APRILIA	Rally *50 LC	47	68	2	10051904
APRILIA	Scarabeo *50 2T	47	68	2	10051906
APRILIA	Scarabeo *50 2T Street Carburatore	47	68	2	10051908
APRILIA	Sonic *50	47	68	2	10051906
APRILIA	Sonic *50 LC	47	68	2	10051904
APRILIA	SR *50 <-1993	47	68	2	10051903
APRILIA	SR *50 1994->	47	68	2	10051906
APRILIA	SR *50 2004 / Piaggio Carburatore	47	68	2	10051902
APRILIA	SR *50 Netscaper LC	47	68	2	10051904
APRILIA	SR *50 R / Piaggio Carburatore	47	68	2	10051902
APRILIA	SR *50 Racing LC	47	68	2	10051904
APRILIA	SR *50 Replica LC	47	68	2	10051904
APRILIA	SR *50 Replica LC 2000 / Aprilia	47	68	2	10051907

MARCA	MODELLO	Ø	CC	TEMPI	CODICE
BRAND	MODEL	Ø	CC	STROKE	ITEM
APRILIA	SR *50 Stealth LC	47	68	2	10051904
APRILIA	SR *50 WWW	47	68	2	10051906
ATALA	Carosello *50	47	68	2	10051906
BENELLI	491 Gt	47	68	2	10051906
BENELLI	491 Sport LC	47	68	2	10051904
BENELLI	K2 *50	47	68	2	10051906
BENELLI	K2 *50 LC	47	68	2	10051904
BENELLI	Naked *50	47	68	2	10051906
BENELLI	Pepe *50	47	68	2	10051906
BETA	Ark *50	47	68	2	10051906
BETA	Ark *50 LC	47	68	2	10051904
BETA	Chrono	47	68	2	10051906
BETA	Eikon *50 LC	47	68	2	10051904
BETA	Quadra	47	68	2	10051906
BETA	Tempo	47	68	2	10051906
BSV	Ax	47	68	2	10051906
BSV	Gz	47	68	2	10051906
CPI	Hussar - Oliver - Popcorn < 2002	47	68	2	10051906



MARCA	MODELLO	Ø	CC	TEMPI	CODICE	MARCA	MODELLO	Ø	CC	TEMPI	CODICE
BRAND	MODEL	Ø	CC	STROKE	ITEM	BRAND	MODEL	Ø	CC	STROKE	ITEM
DERBI	Atlantis *50	47	68	2	10051908	MBK	Sorriso *50 2T <-1995	47	68	2	10051903
DERBI	Bullet *50	47	68	2	10051908	MBK	Sorriso *50 2T 1996->	47	68	2	10051906
DERBI	GP1 *50 LC	47	68	2	10051902	MBK	Stunt *50 2T euro 0-1	47	68	2	10051903
DERBI	GP1 *50 OPEN	47	68	2	10051902	MBK	Stunt *50 2T euro 2	47	68	2	10051903
DERBI	GP1 *50 REVOLUTION	47	68	2	10051902	MBK	Target *50 2T	47	68	2	10051903
FANTIC	Big Wheel *50 2T	47	68	2	10051903	MBK	Thunder 125	47	68	2	10051903
GARELLI	Gsp *50	47	68	2	10051904	P.G.O.	Big Max *50 2T	47	68	2	10051906
GARELLI	Pony *50	47	68	2	10051903	PIAGGIO	Diesis *50 2T	47	68	2	10051908
GARELLI	Sr *50	47	68	2	10051903	PIAGGIO	Fly *50 2T	47	68	2	10051908
GILERA	DNA *50 LC	47	68	2	10051902	PIAGGIO	Free *50 2T	47	68	2	10051908
GILERA	Easy Moving	47	68	2	10051908	PIAGGIO	Liberty *50 2T	47	68	2	10051908
GILERA	Ice *50 2T	47	68	2	10051908	PIAGGIO	NRG *50 LC	47	68	2	10051902
GILERA	Runner *50 LC < 2005	47	68	2	10051902	PIAGGIO	NRG Extreme	47	68	2	10051908
GILERA	Runner *50 SP LC <-2005	47	68	2	10051902	PIAGGIO	NRG Extreme LC	47	68	2	10051902
GILERA	Runner *50 SP LC Carburatore 2006->	47	68	2	10051902	PIAGGIO	NRG Mc2 LC <-1997	47	68	2	10051902
GILERA	Stalker	47	68	2	10051908	PIAGGIO	NRG Mc2 LC 1998->	47	68	2	10051902
GILERA	Storm	47	68	2	10051908	PIAGGIO	NRG Mc3 DD LC	47	68	2	10051902
GILERA	Typhoon	47	68	2	10051908	PIAGGIO	NRG Mc3 DT	47	68	2	10051908
GILERA	Typhoon *50 X	47	68	2	10051908	PIAGGIO	NRG Power DD LC	47	68	2	10051902
ITALJET	Bazooka	47	68	2	10051903	PIAGGIO	NRG Power DT LC	47	68	2	10051908
ITALJET	Dragster *50 LC	47	68	2	10051904	PIAGGIO	NTT LC	47	68	2	10051902
ITALJET	Jet Set *50	47	68	2	10051908	PIAGGIO	Quartz LC	47	68	2	10051902
ITALJET	Pista	47	68	2	10051903	PIAGGIO	Sfera *50	47	68	2	10051908
ITALJET	Pista 2	47	68	2	10051903	PIAGGIO	Sfera *50 Rst	47	68	2	10051908
ITALJET	Reporter	47	68	2	10051903	PIAGGIO	Typhoon *50 2T 2007->2010	47	68	2	10051908
ITALJET	Scoop	47	68	2	10051903	PIAGGIO	Typhoon *50 2T euro 2 - 2011->	47	68	2	10051908
ITALJET	Torpedo *50 2T New	47	68	2	10051908	PIAGGIO	Zip *50 2T	47	68	2	10051908
ITALJET	Yankee	47	68	2	10051903	PIAGGIO	Zip *50 2T / 2000	47	68	2	10051908
LEM	Flash *50 2T	47	68	2	10051903	PIAGGIO	Zip Fast Rider	47	68	2	10051908
LEM	Ghibli *50 2T	47	68	2	10051903	PIAGGIO	Zip SP LC ->2000	47	68	2	10051902
LEM	Tornado *50 2T	47	68	2	10051903	PIAGGIO	Zip SP LC 2001->	47	68	2	10051902
MALAGUTI	Centro *50 2T	47	68	2	10051906	SUZUKI	Katana *50 LC <-1998	47	68	2	10051907
MALAGUTI	Ciak *50	47	68	2	10051906	SUZUKI	Katana *50 LC 1999->	47	68	2	10051907
MALAGUTI	F10	47	68	2	10051906	SUZUKI	Zillion *50 2T	47	68	2	10051907
MALAGUTI	F12 Digit KAT 50 LC	47	68	2	10051904	YAMAHA	Aerox *50 euro 0-1	47	68	2	10051904
MALAGUTI	F12 Digit KAT 50 LC euro 2	47	68	2	10051904	YAMAHA	Aerox *50 euro 2	47	68	2	10051904
MALAGUTI	F12 Phantom *50	47	68	2	10051906	YAMAHA	Axis *50 2T	47	68	2	10051906
MALAGUTI	F12 Phantom *50 LC	47	68	2	10051904	YAMAHA	Breeze *50 2T	47	68	2	10051906
MALAGUTI	F12 R LC euro 2	47	68	2	10051904	YAMAHA	BW'S *50 euro 0-1	47	68	2	10051903
MALAGUTI	F15 Firefox LC	47	68	2	10051904	YAMAHA	BW'S *50 NG euro 0-1	47	68	2	10051903
MALAGUTI	Yesterday	47	68	2	10051906	YAMAHA	BW'S *50 NG euro 2	47	68	2	10051903
MBK	Booster *50 euro 0-1	47	68	2	10051903	YAMAHA	BW'S *50 Original / Naked 2T euro 2 -> 2010	47	68	2	10051903
MBK	Booster *50 Naked euro 2	47	68	2	10051903	YAMAHA	CRZ *50 2T	47	68	2	10051903
MBK	Booster *50 NG euro 0-1	47	68	2	10051903	YAMAHA	CT *50 2T	47	68	2	10051903
MBK	Booster *50 NG euro 2	47	68	2	10051903	YAMAHA	Jog *50	47	68	2	10051906
MBK	Booster *50 Spirit euro 0-1	47	68	2	10051903	YAMAHA	Jog *50 ER	47	68	2	10051906
MBK	Evolis	47	68	2	10051906	YAMAHA	Jog *50 R	47	68	2	10051906
MBK	Fizz	47	68	2	10051906	YAMAHA	Jog *50 RR	47	68	2	10051904
MBK	Flipper	47	68	2	10051906	YAMAHA	Jog *50 Z	47	68	2	10051906
MBK	Forte	47	68	2	10051906	YAMAHA	Neo's *50 2T	47	68	2	10051906
MBK	Hot Champ	47	68	2	10051906	YAMAHA	Slider *50 2T	47	68	2	10051903
MBK	Mach G 50	47	68	2	10051906	YAMAHA	Spy *50 2T	47	68	2	10051903
MBK	Mach G 50 LC	47	68	2	10051904	YAMAHA	Vino *50 2T	47	68	2	10051906
MBK	Nitro *50	47	68	2	10051904	YAMAHA	Why *50 2T	47	68	2	10051906
MBK	Ovetto *50	47	68	2	10051906	YAMAHA	Zest *50 2T	47	68	2	10051906
MBK	Rocket	47	68	2	10051903	YAMAHA	Zuma *50 2T	47	68	2	10051903
MBK	Rocket 50 euro 2	47	68	2	10051903						

Gruppi Termici in Alluminio GForce Spinotto Ø12 Monofascia Aluminum Cylinder Kits GForce Piston pin Ø 12 Single Ring

Realizzati in alluminio con riporto galvanico, sono caratterizzati da un diagramma di distribuzione ed una conformazione delle luci tali da garantire un compromesso ideale tra coppia e potenza massima erogate. Le teste sono state sviluppate per l'uso di benzina senza piombo. I pistoni sono ad 1 segmento per garantire il massimo delle prestazioni.

Made from aluminium with galvanized coating, the thermal units have a distribution diagram and conformation of the openings that provide the ideal compromise between the torque and maximum power supplied. The heads have been developed for use with unleaded petrol. The pistons are made in one segment to allow maximum performances.



MARCA	MODELLO	Ø	CC	TEMPI	CODICE
BRAND	MODEL	Ø	CC	STROKE	ITEM
APRILIA	Area 51	47	68	2	10051924
APRILIA	Gulliver *50	47	68	2	10051926
APRILIA	Gulliver *50 LC	47	68	2	10051924
APRILIA	Rally *50	47	68	2	10051926
APRILIA	Rally *50 LC	47	68	2	10051924
APRILIA	Scarabeo *50 2T	47	68	2	10051926
APRILIA	Sonic *50	47	68	2	10051926
APRILIA	Sonic *50 LC	47	68	2	10051924
APRILIA	SR *50 1994->	47	68	2	10051926
APRILIA	SR *50 Netscaper LC	47	68	2	10051924
APRILIA	SR *50 Racing LC	47	68	2	10051924
APRILIA	SR *50 Replica LC	47	68	2	10051924
APRILIA	SR *50 Stealth LC	47	68	2	10051924
APRILIA	SR *50 WWW	47	68	2	10051926
ATALA	Carosello *50	47	68	2	10051926
BENELLI	491 Gt	47	68	2	10051926
BENELLI	491 Sport LC	47	68	2	10051924
BENELLI	K2 *50	47	68	2	10051926
BENELLI	K2 *50 LC	47	68	2	10051924
BENELLI	Naked *50	47	68	2	10051926
BENELLI	Pepe *50	47	68	2	10051926
BETA	Ark *50	47	68	2	10051926
BETA	Ark *50 LC	47	68	2	10051924
BETA	Chrono	47	68	2	10051926
BETA	Eikon *50 LC	47	68	2	10051924
BETA	Quadra	47	68	2	10051926
BETA	Tempo	47	68	2	10051926
BSV	Ax	47	68	2	10051926
BSV	Gz	47	68	2	10051926
CPI	Hussar - Oliver - Popcorn < 2002	47	68	2	10051926
GARELLI	Gsp *50	47	68	2	10051924
ITALJET	Dragster *50 LC	47	68	2	10051924
MALAGUTI	Centro *50 2T	47	68	2	10051926

MARCA	MODELLO	Ø	CC	TEMPI	CODICE
BRAND	MODEL	Ø	CC	STROKE	ITEM
MALAGUTI	Ciak *50	47	68	2	10051926
MALAGUTI	F10	47	68	2	10051925
MALAGUTI	F12 Digit KAT 50 LC	47	68	2	10051924
MALAGUTI	F12 Digit KAT 50 LC euro 2	47	68	2	10051924
MALAGUTI	F12 Phantom *50	47	68	2	10051926
MALAGUTI	F12 Phantom *50 LC	47	68	2	10051924
MALAGUTI	F12 R LC euro 2	47	68	2	10051924
MALAGUTI	F15 Firefox LC	47	68	2	10051924
MALAGUTI	Yesterday	47	68	2	10051926
MBK	Evolis	47	68	2	10051926
MBK	Fizz	47	68	2	10051926
MBK	Flipper	47	68	2	10051926
MBK	Forte	47	68	2	10051926
MBK	Hot Champ	47	68	2	10051926
MBK	Mach G 50	47	68	2	10051926
MBK	Mach G 50 LC	47	68	2	10051924
MBK	Nitro *50	47	68	2	10051924
MBK	Ovetto *50	47	68	2	10051926
MBK	Sorriso *50 2T 1996->	47	68	2	10051926
P.G.O.	Big Max *50 2T	47	68	2	10051926
YAMAHA	Aerox *50 euro 0-1	47	68	2	10051924
YAMAHA	Aerox *50 euro 2	47	68	2	10051924
YAMAHA	Axis *50 2T	47	68	2	10051926
YAMAHA	Breeze *50 2T	47	68	2	10051926
YAMAHA	Jog *50	47	68	2	10051926
YAMAHA	Jog *50 ER	47	68	2	10051926
YAMAHA	Jog *50 R	47	68	2	10051926
YAMAHA	Jog *50 RR	47	68	2	10051924
YAMAHA	Jog *50 Z	47	68	2	10051926
YAMAHA	Neo's *50 2T	47	68	2	10051926
YAMAHA	Vino *50 2T	47	68	2	10051926
YAMAHA	Why *50 2T	47	68	2	10051926
YAMAHA	Zest *50 2T	47	68	2	10051926

Ricambi | Spare parts

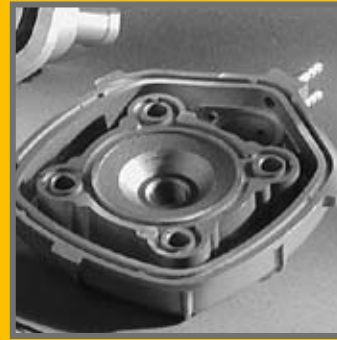
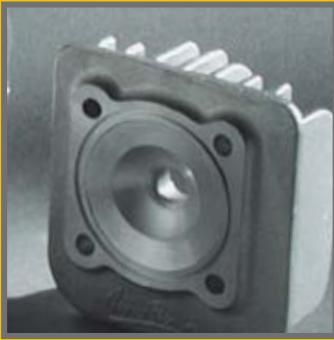

CODICE	APPLICAZIONE	TIPO	Ø	PISTONE COMPLETO	SEGMENTO	SERIE SEGMENTI	TESTA	SERIE GUARNIZ.
ITEM	MODEL	MODE	Ø	COMPLETE PISTON	RING	RING SET	HEAD	GASKET SET
10040402	Gilera Runner - Piaggio Zip SP	LC	47	10121197 - Ø 47,0 10121201 - Ø 47,4	-	10173504 - Ø 47,0 10173505 - Ø 47,4	10243636	10332102
10040403	Aprilia Amico - MbK Booster	AIR	47	10121198 - Ø 47,0 10121199 - Ø 47,4	-	10173504 - Ø 47,0 10173505 - Ø 47,4	10241028	10332103
10040404	Aprilia Sr Replica LC - Malaguti F12 LC	LC	47	10121196 - Ø 47,0 10121200 - Ø 47,4	-	10173504 - Ø 47,0 10173505 - Ø 47,4	10243633	10332104
10040406	Aprilia Sr - Malaguti F12	AIR	47	10121196 - Ø 47,0 10121200 - Ø 47,4	-	10173504 - Ø 47,0 10173505 - Ø 47,4	10241027	10332106
10040407	Aprilia Sr Replica 2000 LC - Suzuki Katana LC	LC	47	-	-	-	-	-
10040408	Gilera Typhoon - Piaggio Zip	AIR	47	10121197 - Ø 47,0 10121201 - Ø 47,4	-	10173504 - Ø 47,0 10173505 - Ø 47,4	-	10332108
10040424	Aprilia Sr Replica LC - Malaguti F12 LC / SP. Ø 12	LC	47	10121197 - Ø 47,0 10121201 - Ø 47,4	-	10173504 - Ø 47,0 10173505 - Ø 47,4	10243633	10332104
10040426	Aprilia Sr - Malaguti F12 / SP. Ø 12	AIR	47	10121197 - Ø 47,0 10121201 - Ø 47,4	-	10173504 - Ø 47,0 10173505 - Ø 47,4	10241027	10332106
10041402	Gilera Runner - Piaggio Zip SP	LC	47	10121102 - Ø 47,0	10114506	-	10243636	10332102
10041403	Aprilia Amico - MbK Booster	AIR	47	10121104 - Ø 47,0	10114506	-	10241028	10332103
10041404	Aprilia Sr Replica LC - Malaguti F12 LC	LC	47	10121103 - Ø 47,0	10114506	-	10243633	10332104
10041406	Aprilia Sr - Malaguti F12	AIR	47	10121103 - Ø 47,0	10114506	-	10241027	10332106
10041408	Gilera Typhoon - Piaggio Zip	AIR	47	10121102 - Ø 47,0	10114506	-	10241026	10332108
10041424	Aprilia Sr Replica LC - Malaguti F12 LC / SP. Ø 12	AIR	47	10121102 - Ø 47,0	10114506	-	10243633	10332104
10041426	Aprilia Sr - Malaguti F12 / SP. Ø 12	LC	47	10121102 - Ø 47,0	10114506	-	10241027	10332106
10051902	Gilera Runner - Piaggio Zip SP	LC	47	10121100	10114504	-	10243636	10332002
10051903	Aprilia Amico - MbK Booster	AIR	47	10121105	10114504	-	10241028	10332003
10051904	Aprilia Sr Replica LC - Malaguti F12 LC	LC	47	10121101	10114504	-	10243633	10332004
10051906	Aprilia Sr - Malaguti F12	AIR	47	10121101	10114504	-	10241027	10332006
10051908	Gilera Typhoon - Piaggio Zip	AIR	47	10121100	10114504	-	10241026	10332008
10051924	Aprilia Sr Replica LC - Malaguti F12 LC / SP. Ø 12	AIR	47	10121101	10114504	-	10243633	10332004
10051926	Aprilia Sr - Malaguti F12 / SP. Ø 12	LC	47	10121101	10114504	-	10241027	10332006
10059901	Gilera Typhoon - Piaggio Zip	AIR	46	10121190	-	10173501	10241029	10332001
10059902	Gilera Runner - Piaggio Zip SP	LC	47	10121191	-	10173502	10243636	10332002
10059903	Aprilia Amico - MbK Booster	AIR	47	10121193	-	10173502	10241028	10332003
10059904	Aprilia Sr Replica LC - Malaguti F12 LC	LC	47	10121192	-	10173502	10243633	10332004
10059905	Italjet Formula - Suzuki Katana	AIR	46	10121194	-	-	-	10332005
10059906	Aprilia Sr - Malaguti F12	AIR	47	10121192	-	10173502	10241027	10332006
10059907	Aprilia Sr Replica 2000 LC - Suzuki Katana LC	LC	47	-	-	-	-	10332007
10059908	Gilera Typhoon - Piaggio Zip	AIR	47	10121191	-	10173502	10241026	10332008
10059909	Aprilia - Beta - HM - Yamaha / Motore AM	LC	47	10121195	-	10173503	-	10332009

Marmitte Powersound Powersound Silencers

Interamente realizzate a mano con i migliori materiali e con grande attenzione per la finitura, sono prive di paratie di silenziamento interno per fornire prestazioni elevatissime sia ai bassi che agli alti regimi. Un accurato studio del silenziatore ha permesso di contenere le emissioni sonore entro valori estremamente bassi.

Entirely handmade from the best materials available and with great attention paid to their finish, the silencers have no internal muffler walls so that they give excellent performance at both high and low engine speeds. Careful design of the silencers means that sound emissions are kept to very low levels.



MARCA	MODELLO	MARMITTE Powersound	OMOLOGATA 97/24
BRAND	MODEL	PowerSound Silencers	HOMOLOGATION 97/24
APRILIA	Amico *50	10561124	NO
APRILIA	Gulliver *50	10561127	NO
APRILIA	Gulliver *50 LC	10561127	NO
APRILIA	Rally *50	10561127	SI/YES
APRILIA	Rally *50 LC	10561127	SI/YES
APRILIA	Scarabeo *50 2T	10561127	NO
APRILIA	Scarabeo *50 2T Street Carburatore	10561130	SI/YES
APRILIA	Sonic *50	10561127	NO
APRILIA	Sonic *50 LC	10561127	NO
APRILIA	SR *50 <-1993	10561124	NO
APRILIA	SR *50 1994->	10561127	SI/YES
APRILIA	SR *50 2004 / Piaggio Carburatore	10561125	NO
APRILIA	SR *50 DiTech GP1 / Piaggio Iniezione	10561130	SI/YES
APRILIA	SR *50 Netscaper LC	10561127	SI/YES
APRILIA	SR *50 R / Piaggio Carburatore	10561130	SI/YES
APRILIA	SR *50 R Factory	10561130	SI/YES
APRILIA	SR *50 Racing LC	10561127	SI/YES
APRILIA	SR *50 Replica LC	10561127	SI/YES
APRILIA	SR *50 Stealth LC	10561127	SI/YES
APRILIA	SR *50 WWW	10561127	SI/YES
BENELLI	491 Gt	10561127	NO

MARCA	MODELLO	MARMITTE Powersound	OMOLOGATA 97/24
BRAND	MODEL	PowerSound Silencers	HOMOLOGATION 97/24
BENELLI	491 Sport LC	10561127	NO
BENELLI	K2 *50	10561127	NO
BENELLI	K2 *50 LC	10561127	NO
BENELLI	Naked *50	10561127	NO
BETA	Ark *50	10561127	NO
BETA	Ark *50 LC	10561127	NO
BETA	Chrono	10561127	NO
BETA	Quadra	10561127	NO
BSV	Ax	10561127	NO
BSV	Gz	10561127	NO
FANTIC	Big Wheel *50 2T	10561124	NO
GILERA	Easy Moving	10561125	NO
GILERA	Runner *50 LC < 2005	10561125	SI/YES
GILERA	Runner *50 PureJet <-2005	10561130	SI/YES
GILERA	Runner *50 PureJet 2006->	10561130	SI/YES
GILERA	Runner *50 SP LC <-2005	10561125	SI/YES
GILERA	Runner *50 SP LC Carburatore 2006->	10561125	SI/YES
GILERA	Stalker	10561125	SI/YES
GILERA	Storm	10561125	NO
GILERA	Typhoon	10561125	SI/YES
GILERA	Typhoon *50 X	10561125	SI/YES

MARCA	MODELLO	MARMITTE PowerSound	OMOLOGATA 97/24
BRAND	MODEL	PowerSound Silencers	HOMOLOGATION 97/24
ITALJET	Pista	10561124	NO
ITALJET	Scoop	10561124	NO
ITALJET	Yankee	10561124	NO
MALAGUTI	F10	10561127	SI/YES
MALAGUTI	F12 Digit KAT 50 LC	10561127	NO
MALAGUTI	F12 Digit KAT 50 LC euro 2	10561127	NO
MALAGUTI	F12 Phantom *50	10561127	SI/YES
MALAGUTI	F12 Phantom *50 LC	10561127	SI/YES
MALAGUTI	F12 R LC euro 2	10561127	NO
MALAGUTI	F15 Firefox LC	10561127	NO
MALAGUTI	Yesterday	10561127	NO
MBK	Booster *50 euro 0-1	10561124	SI/YES
MBK	Booster *50 Naked euro 2	10561124	NO
MBK	Booster *50 NG euro 0-1	10561124	SI/YES
MBK	Booster *50 NG euro 2	10561124	NO
MBK	Booster *50 Spirit euro 0-1	10561124	SI/YES
MBK	Evolis	10561127	NO
MBK	Fizz	10561127	NO
MBK	Flipper	10561127	NO
MBK	Forte	10561127	NO
MBK	Hot Champ	10561127	NO
MBK	Nitro *50	10561123	SI/YES
MBK	Ovetto *50	10561127	SI/YES
MBK	Rocket	10561124	NO
MBK	Rocket 50 euro 2	10561124	NO
MBK	Sorriso *50 2T 1996->	10561127	NO
MBK	Stunt *50 2T euro 2	10561124	NO
MBK	Target *50 2T	10561124	NO
MBK	Thunder 125	10561124	NO
PIAGGIO	Free *50 2T	10561125	NO
PIAGGIO	Liberty *50 2T	10561125	NO
PIAGGIO	NRG *50 LC	10561125	NO
PIAGGIO	NRG Extreme	10561125	NO
PIAGGIO	NRG Extreme LC	10561125	NO
PIAGGIO	NRG Mc2 LC <-1997	10561125	SI/YES
PIAGGIO	NRG Mc2 LC 1998->	10561125	SI/YES
PIAGGIO	NRG Mc3 DD LC	10561125	SI/YES
PIAGGIO	NRG Mc3 DT	10561125	SI/YES
PIAGGIO	NRG Mc3 PureJet LC	10561130	SI/YES
PIAGGIO	NRG Power DD LC	10561125	NO
PIAGGIO	NRG Power DT LC	10561125	NO
PIAGGIO	NRG Power PureJet	10561130	SI/YES
PIAGGIO	NTT LC	10561125	NO
PIAGGIO	Quartz LC	10561125	NO
PIAGGIO	Sfera *50 Rst	10561125	NO
PIAGGIO	Typhoon *50 2T euro 2 - 2011->	10561125	NO
PIAGGIO	Zip *50 2T	10561125	NO
PIAGGIO	Zip *50 2T / 2000	10561125	NO
PIAGGIO	Zip Fast Rider	10561125	NO
PIAGGIO	Zip SP LC ->2000	10561125	NO
PIAGGIO	Zip SP LC 2001->	10561125	NO
VESPA	Vespa ET2 *50 - Carburatore	10561125	NO
YAMAHA	Aerox *50 euro 0-1	10561123	SI/YES
YAMAHA	Aerox *50 euro 2	10561123	NO
YAMAHA	Axis *50 2T	10561127	NO
YAMAHA	Breeze *50 2T	10561127	NO
YAMAHA	BW'S *50 euro 0-1	10561124	SI/YES
YAMAHA	BW'S *50 NG euro 0-1	10561124	SI/YES
YAMAHA	BW'S *50 NG euro 2	10561124	SI/YES
YAMAHA	BW'S *50 Original / Naked 2T euro 2 > 2010	10561124	NO
YAMAHA	Jog *50	10561127	NO
YAMAHA	Jog *50 ER	10561127	NO
YAMAHA	Jog *50 R	10561127	NO
YAMAHA	Jog *50 Z	10561127	NO
YAMAHA	Neo's *50 2T	10561127	NO
YAMAHA	Spy *50 2T	10561124	NO
YAMAHA	Zest *50 2T	10561127	NO
YAMAHA	Zuma *50 2T	10561124	NO



Ricambi | Spare parts

CODICE	APPLICAZIONE
ITEM	APPLICATION
10340001	SILENZIATORE IN ALLUMINIO
10340524	COLLETTORE SCARICO MARMITTA POWERSOUND 10561124
10340525	COLLETTORE SCARICO MARMITTA POWERSOUND 10561125
10340527	COLLETTORE SCARICO MARMITTA POWERSOUND 10561127 / 10561123
10340530	COLLETTORE SCARICO MARMITTA POWERSOUND 10561130
10341000	LANA DI ROCCIA PER SILENZIATORE
10341001	FASCETTA SILENZIATORE POWERSOUND
10341002	GUARNIZIONE SILENZIATORE POWERSOUND
10341124	KIT STAFFA + COLLETTORE SCARICO 10561124
10341125	KIT STAFFA + COLLETTORE SCARICO 10561125
10341127	KIT STAFFA + COLLETTORE SCARICO 10561127
10341130	KIT STAFFA + COLLETTORE SCARICO 10561130

Alberi motore Crankshafts

Alberi motore realizzati in acciaio K2D trattato termicamente, lavorati con macchinari a controllo numerico, assemblati e centrati con la massima cura utilizzando cuscinetti di biella di altissima qualità e bielle specifiche per competizione.

Crankshafts made of K2D steel heat-treated, CNC machined, assembled and centered, top quality rods and rod bearings.

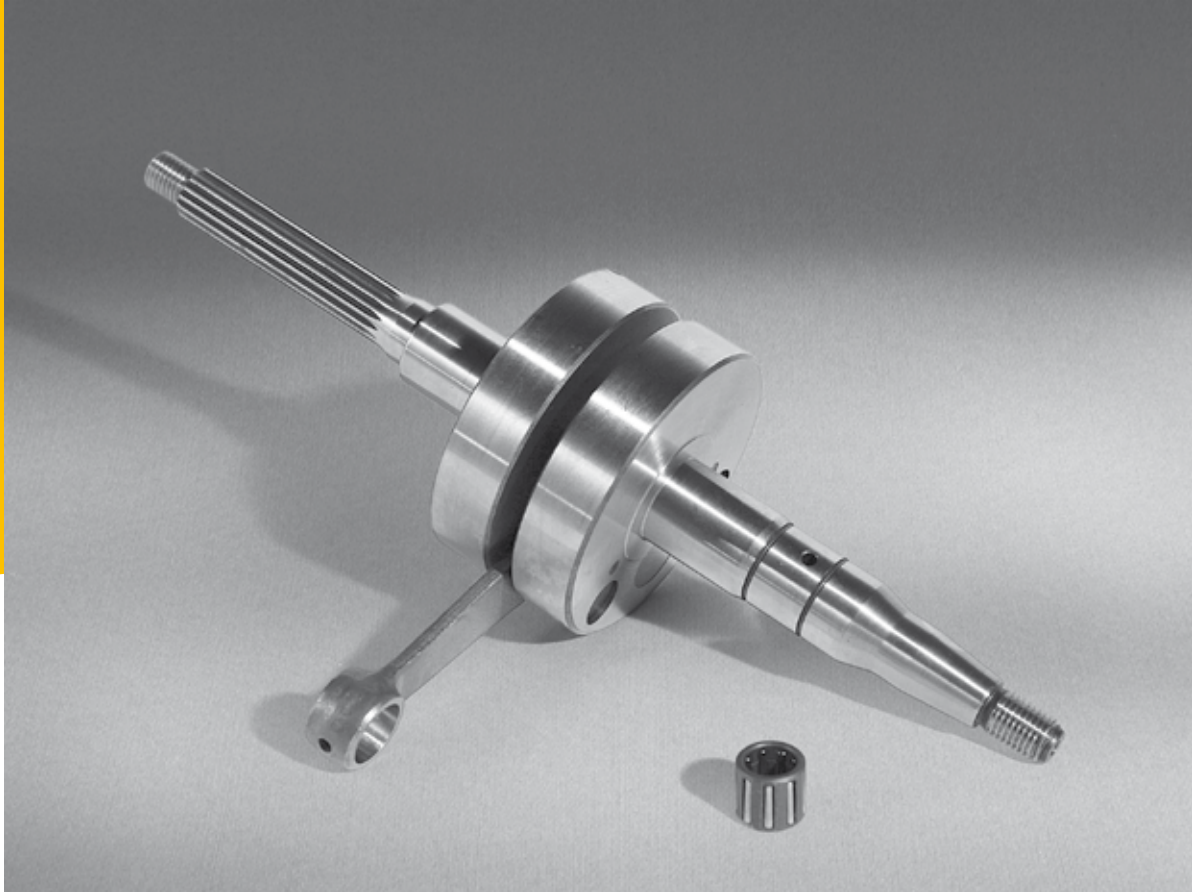

CODICE	APPLICAZIONE	CC	TEMPI	ALBERI MOTORE Ø10	ALBERI MOTORE Ø12
ITEM	MODEL	CC	STROKE	CRANKSHAFT Ø10	CRANKSHAFT Ø12
APRILIA	Amico *50	50	2	10080803	-
APRILIA	Area 51	50	2	10080806	10080804
APRILIA	Gulliver *50	50	2	10080806	10080804
APRILIA	Gulliver *50 LC	50	2	10080806	10080804
APRILIA	Mojito *50 Custom	50	2	-	10080802
APRILIA	Rally *50	50	2	10080806	10080804
APRILIA	Rally *50 LC	50	2	10080806	10080804
APRILIA	Scarabeo *50 2T	50	2	10080806	10080804
APRILIA	Scarabeo *50 2T Street Carburatore	50	2	-	10080802
APRILIA	Sonic *50	50	2	10080806	10080804
APRILIA	Sonic *50 LC	50	2	10080806	10080804
APRILIA	SR *50 <-1993	50	2	10080803	-
APRILIA	SR *50 1994->	50	2	10080806	10080804
APRILIA	SR *50 2004 / Piaggio Carburatore	50	2	-	10080802
APRILIA	SR *50 Netscaper LC	50	2	10080806	10080804
APRILIA	SR *50 R / Piaggio Carburatore	50	2	-	10080802
APRILIA	SR *50 Racing LC	50	2	10080806	10080804
APRILIA	SR *50 Replica LC	50	2	10080806	10080804
APRILIA	SR *50 Stealth LC	50	2	10080806	10080804
APRILIA	SR *50 WWW	50	2	10080806	10080804
ATALA	Carosello *50	50	2	10080806	10080804
BENELLI	491 Gt	50	2	10080806	10080804
BENELLI	491 Sport LC	50	2	10080806	10080804
BENELLI	K2 *50	50	2	10080806	10080804
BENELLI	K2 *50 LC	50	2	10080806	10080804

CODICE	APPLICAZIONE	CC	TEMPI	ALBERI MOTORE Ø10	ALBERI MOTORE Ø12
ITEM	MODEL	CC	STROKE	CRANKSHAFT Ø10	CRANKSHAFT Ø12
BENELLI	Naked *50	50	2	10080806	10080804
BENELLI	Pepe *50	50	2	10080806	10080804
BENELLI	Pepe LX *50 euro 2	50	2	-	10080811
BENELLI	QuattroNove X *50 euro 2	50	2	-	10080811
BETA	Ark *50	50	2	10080806	10080804
BETA	Ark *50 LC	50	2	10080806	10080804
BETA	Chrono	50	2	10080806	10080804
BETA	Eikon *50 LC	50	2	10080806	10080804
BETA	Quadra	50	2	10080806	10080804
BETA	Tempo	50	2	10080806	10080804
BSV	Ax	50	2	10080806	10080804
BSV	Gz	50	2	10080806	10080804
CPI	Aragon GP - Hussar - Oliver - Popcorn 2003 >	50	2	-	10080811
CPI	Hussar - Oliver - Popcorn < 2002	50	2	10080806	10080804
CPI	Aragon GP - Hussar - Oliver - Popcorn > 2003	50	2	-	10080811
DERBI	Atlantis *50	50	2	-	10080802
DERBI	Atlantis *50 LC	50	2	-	10080802
DERBI	Bullet *50	50	2	-	10080802
DERBI	GP1 *50 LC	50	2	-	10080802
DERBI	GP1 *50 OPEN	50	2	-	10080802
DERBI	GP1 *50 REVOLUTION	50	2	-	10080802
EXPLORER	Cracker *50 2003>	50	2	-	10080811
FANTIC	Big Wheel *50 2T	50	2	10080803	-
GARELLI	Gsp *50	50	2	10080806	10080804
GARELLI	Pony *50	50	2	10080803	-
GARELLI	Sr *50	50	2	10080803	-
GARELLI	Tiesse *50 R	50	2	-	10080811
GILERA	DNA *50 LC	50	2	-	10080802
GILERA	Easy Moving	50	2	-	10080802
GILERA	Ice *50 2T	50	2	-	10080802
GILERA	Runner *50 LC < 2005	50	2	-	10080802
GILERA	Runner *50 SP LC <-2005	50	2	-	10080802
GILERA	Runner *50 SP LC Carburatore 2006->	50	2	-	10080802
GILERA	Stalker	50	2	-	10080802
GILERA	Storm	50	2	-	10080802
GILERA	Typhoon	50	2	-	10080802
GILERA	Typhoon *50 X	50	2	-	10080802
HONDA	Bali *50	50	2	-	10080802
HUPPER	Montecarlo 30 2T	50	2	-	10080811
ITALJET	Bazooka	50	2	10080803	-
ITALJET	Dragster *50 LC	50	2	10080806	10080804
ITALJET	Pista	50	2	10080803	-
ITALJET	Pista 2	50	2	10080803	-
ITALJET	Reporter	50	2	10080803	-
ITALJET	Scoop	50	2	10080803	-
ITALJET	Yankee	50	2	10080803	-
KEEWAY	F-ACT	50	2	-	10080811
KEEWAY	Goccia	50	2	-	10080811
KEEWAY	Hurricane	50	2	-	10080811
KEEWAY	Matrix	50	2	-	10080811
KEEWAY	Pixel	50	2	-	10080811
KEEWAY	RY8	50	2	-	10080811
LEM	Flash *50 2T	50	2	10080803	-
LEM	Ghibli *50 2T	50	2	10080803	-
LEM	Tornado *50 2T	50	2	10080803	-
MALAGUTI	Centro *50 2T	50	2	10080806	10080804
MALAGUTI	Ciak *50	50	2	10080806	10080804
MALAGUTI	F10	50	2	10080806	10080804
MALAGUTI	F10 Wap	50	2	-	10080811
MALAGUTI	F12 Digit KAT 50 LC	50	2	10080806	10080802
MALAGUTI	F12 Digit KAT 50 LC euro 2	50	2	10080806	10080803
MALAGUTI	F12 Phantom *50	50	2	10080806	10080804
MALAGUTI	F12 Phantom *50 LC	50	2	10080806	10080804
MALAGUTI	F12 R AIR euro 2	50	2	-	10080811
MALAGUTI	F12 R LC euro 2	50	2	10080806	10080804
MALAGUTI	F15 Firefox LC	50	2	10080806	10080804
MALAGUTI	Yesterday	50	2	10080806	10080804



CODICE	APPLICAZIONE	CC	TEMPI	ALBERI MOTORE Ø10	ALBERI MOTORE Ø12
ITEM	MODEL	CC	STROKE	CRANKSHAFT Ø10	CRANKSHAFT Ø12
MBK	Booster *50 euro 0-1	50	2	10080803	-
MBK	Booster *50 Naked euro 2	50	2	10080803	-
MBK	Booster *50 NG euro 0-1	50	2	10080803	-
MBK	Booster *50 NG euro 2	50	2	10080803	-
MBK	Booster *50 Spirit euro 0-1	50	2	10080803	-
MBK	Evolis	50	2	10080806	10080804
MBK	Fizz	50	2	10080806	10080804
MBK	Flipper	50	2	10080806	10080804
MBK	Forte	50	2	10080806	10080804
MBK	Hot Champ	50	2	10080806	10080804
MBK	Mach G 50	50	2	10080806	10080804
MBK	Mach G 50 LC	50	2	10080806	10080804
MBK	Nitro *50	50	2	10080806	10080804
MBK	Ovetto *50	50	2	10080806	10080804
MBK	Rocket	50	2	10080803	-
MBK	Rocket 50 euro 2	50	2	10080803	-
MBK	Sorriso *50 2T <-1995	50	2	10080803	-
MBK	Sorriso *50 2T 1996->	50	2	10080806	10080804
MBK	Stunt *50 2T euro 0-1	50	2	10080803	-
MBK	Stunt *50 2T euro 2	50	2	10080803	-
MBK	Target *50 2T	50	2	10080803	-
P.G.O.	Big Max *50 2T	50	2	10080806	10080804
PIAGGIO	Diesis *50 2T	50	2	-	10080802
PIAGGIO	Fly *50 2T	50	2	-	10080802
PIAGGIO	Free *50 2T	50	2	-	10080802
PIAGGIO	Liberty *50 2T	50	2	-	10080802
PIAGGIO	NRG *50 LC	50	2	-	10080802
PIAGGIO	NRG Extreme	50	2	-	10080802
PIAGGIO	NRG Extreme LC	50	2	-	10080802
PIAGGIO	NRG Mc2 LC <-1997	50	2	-	10080802
PIAGGIO	NRG Mc2 LC 1998->	50	2	-	10080802
PIAGGIO	NRG Mc3 DD LC	50	2	-	10080802
PIAGGIO	NRG Mc3 DT	50	2	-	10080802
PIAGGIO	NRG Power DD LC	50	2	-	10080802
PIAGGIO	NTT LC	50	2	-	10080802
PIAGGIO	Quartz LC	50	2	-	10080802
PIAGGIO	Sfera *50	50	2	-	10080802
PIAGGIO	Sfera *50 Rst	50	2	-	10080802
PIAGGIO	Typhoon *50 2T 2007->2010	50	2	-	10080802
PIAGGIO	Typhoon *50 2T euro 2 - 2011->	50	2	-	10080802
PIAGGIO	Zip *50 2T	50	2	-	10080802
PIAGGIO	Zip *50 2T / 2000	50	2	-	10080802
PIAGGIO	Zip Fast Rider	50	2	-	10080802
PIAGGIO	Zip SP LC ->2000	50	2	-	10080802
PIAGGIO	Zip SP LC 2001->	50	2	-	10080802
YAMAHA	Aerox *50 euro 0-1	50	2	10080806	10080804
YAMAHA	Aerox *50 euro 2	50	2	10080806	10080804
YAMAHA	Axis *50 2T	50	2	10080806	10080804
YAMAHA	Breeze *50 2T	50	2	10080806	10080804
YAMAHA	BW'S *50 euro 0-1	50	2	10080803	-
YAMAHA	BW'S *50 NG euro 0-1	50	2	10080803	-
YAMAHA	BW'S *50 NG euro 2	50	2	10080803	-
YAMAHA	BW'S *50 Original / Naked 2T euro 2 > 2010	50	2	10080803	-
YAMAHA	CRZ *50 2T	50	2	10080803	-
YAMAHA	CT *50 2T	50	2	10080803	-
YAMAHA	Jog *50	50	2	10080806	10080804
YAMAHA	Jog *50 ER	50	2	10080806	10080804
YAMAHA	Jog *50 R	50	2	10080806	10080804
YAMAHA	Jog *50 RR	50	2	10080806	10080804
YAMAHA	Jog *50 Z	50	2	10080806	10080804
YAMAHA	Neo's *50 2T	50	2	10080806	10080804
YAMAHA	Slider *50 2T	50	2	10080803	-
YAMAHA	Spy *50 2T	50	2	10080803	-
YAMAHA	Vino *50 2T	50	2	10080806	10080804
YAMAHA	Why *50 2T	50	2	10080806	10080804
YAMAHA	Zest *50 2T	50	2	10080806	10080804
YAMAHA	Zuma *50 2T	50	2	10080803	-



Carburatori Ø 17,5 Carburettors Ø 17,5

Uno tra i carburatori scooter più evoluti in commercio, grazie al diffusore centrato ed alla conformazione a scudetto della valvola gas. Fornito con starter manuale o automatico, con tutti gli accessori per il montaggio e già tarato per ogni scooter.

One of the most advanced scooter carburettors available, thanks to the centred choke and shield conformation of the gas valve. Supplied with a manual or automatic starter, with all mounting accessories and pre-calibrated for each scooter.



MARCA	MODELLO	CC	TEMPI	CODICE
BRAND	MODEL	CC	STROKE	ITEM
APRILIA	Amico *50	50	2	10294896
APRILIA	Area 51	50	2	10294896
APRILIA	Gulliver *50	50	2	10294896
APRILIA	Gulliver *50 LC	50	2	10294896
APRILIA	Mojito *50 Custom	50	2	10294895
APRILIA	Rally *50	50	2	10294896
APRILIA	Rally *50 LC	50	2	10294896
APRILIA	Scarabeo *50 2T	50	2	10294896
APRILIA	Scarabeo *50 2T Street Carburatore	50	2	10294895
APRILIA	Sonic *50	50	2	10294896
APRILIA	Sonic *50 LC	50	2	10294896
APRILIA	SR *50 <-1993	50	2	10294896
APRILIA	SR *50 1994->	50	2	10294896
APRILIA	SR *50 2004 / Piaggio Carburatore	50	2	10294895
APRILIA	SR *50 Netscaper LC	50	2	10294896
APRILIA	SR *50 R / Piaggio Carburatore	50	2	10294895
APRILIA	SR *50 Racing LC	50	2	10294896
APRILIA	SR *50 Replica LC	50	2	10294896
APRILIA	SR *50 Stealth LC	50	2	10294896
APRILIA	SR *50 WWW	50	2	10294896
ATALA	Carosello *50	50	2	10294897
BENELLI	491 Gt	50	2	10294897
BENELLI	491 Sport LC	50	2	10294896
BENELLI	K2 *50	50	2	10294897

MARCA	MODELLO	CC	TEMPI	CODICE
BRAND	MODEL	CC	STROKE	ITEM
BENELLI	K2 *50 LC	50	2	10294896
BENELLI	Naked *50	50	2	10294897
BENELLI	Pepe *50	50	2	10294897
BENELLI	Pepe LX *50 euro 2	50	2	10294897
BENELLI	QuattroNove X *50 euro 2	50	2	10294897
BETA	Ark *50	50	2	10294897
BETA	Ark *50 LC	50	2	10294896
BETA	Chrono	50	2	10294897
BETA	Eikon *50 LC	50	2	10294896
BETA	Quadra	50	2	10294897
BETA	Tempo	50	2	10294897
BSV	Ax	50	2	10294896
BSV	Gz	50	2	10294896
CPI	Aragon GP - Hussar - Oliver - Popcorn 2003 >	50	2	10294897
CPI	Hussar - Oliver - Popcorn < 2002	50	2	10294897
CPI	Aragon GP - Hussar - Oliver - Popcorn > 2003	50	2	10294897
DERBI	Bullet *50	50	2	10294895
DERBI	GP1 *50 LC	50	2	10294895
DERBI	GP1 *50 OPEN	50	2	10294895
DERBI	GP1 *50 REVOLUTION	50	2	10294895
EXPLORER	Cracker *50 2003>	50	2	10294897
FANTIC	Big Wheel *50 2T	50	2	10294896
GARELLI	Gsp *50	50	2	10294896
GARELLI	Pony *50	50	2	10294896

MARCA	MODELLO	CC	TEMPI	CODICE
BRAND	MODEL	CC	STROKE	ITEM
GARELLI	Sr *50	50	2	10294896
GARELLI	Tiesse *50 R	50	2	10294897
GILERA	Easy Moving	50	2	10294895
GILERA	Ice *50 2T	50	2	10294895
GILERA	Runner *50 LC < 2005	50	2	10294895
GILERA	Runner *50 SP LC <-2005	50	2	10294895
GILERA	Runner *50 SP LC Carburatore 2006->	50	2	10294895
GILERA	Stalker	50	2	10294895
GILERA	Storm	50	2	10294895
GILERA	Typhoon	50	2	10294895
GILERA	Typhoon *50 X	50	2	10294895
HONDA	Bali *50	50	2	10294898
HONDA	SFX *50	50	2	10294898
HONDA	SH *50 - 1996->	50	2	10294898
HONDA	Shadow *50	50	2	10294898
HONDA	Sky *50	50	2	10294898
HONDA	X8R X-S	50	2	10294898
HUPPER	Montecarlo 30 2T	50	2	10294897
ITALJET	Bazooka	50	2	10294896
ITALJET	Dragster *50 LC	50	2	10294896
ITALJET	Jet Set *50	50	2	10294895
ITALJET	Pista	50	2	10294896
ITALJET	Pista 2	50	2	10294896
ITALJET	Reporter	50	2	10294896
ITALJET	Scoop	50	2	10294896
ITALJET	Torpedo *50 4T	50	4	10294895
ITALJET	Yankee	50	2	10294896
KEEWAY	F-ACT	50	2	10294897
KEEWAY	Goccia	50	2	10294897
KEEWAY	Hurricane	50	2	10294897
KEEWAY	Matrix	50	2	10294897
KEEWAY	Pixel	50	2	10294897
KEEWAY	RY8	50	2	10294897
LEM	Flash *50 2T	50	2	10294896
LEM	Ghibli *50 2T	50	2	10294896
LEM	Tornado *50 2T	50	2	10294896
MALAGUTI	Centro *50 2T	50	2	10294897
MALAGUTI	Ciak *50	50	2	10294897
MALAGUTI	F10	50	2	10294896
MALAGUTI	F10 Wap	50	2	10294897
MALAGUTI	F12 Digit KAT 50 LC	50	2	10294896
MALAGUTI	F12 Digit KAT 50 LC euro 2	50	2	10294896
MALAGUTI	F12 Phantom *50	50	2	10294897
MALAGUTI	F12 Phantom *50 LC	50	2	10294896
MALAGUTI	F12 R AIR euro 2	50	2	10294897
MALAGUTI	F12 R LC euro 2	50	2	10294896
MALAGUTI	F15 Firefox LC	50	2	10294896
MALAGUTI	Yesterday	50	2	10294897
MBK	Booster *50 euro 0-1	50	2	10294896
MBK	Booster *50 Naked euro 2	50	2	10294896
MBK	Booster *50 NG euro 0-1	50	2	10294896
MBK	Booster *50 NG euro 2	50	2	10294896
MBK	Booster *50 Spirit euro 0-1	50	2	10294896
MBK	Evolis	50	2	10294896
MBK	Fizz	50	2	10294896
MBK	Flipper	50	2	10294896
MBK	Forte	50	2	10294896

MARCA	MODELLO	CC	TEMPI	CODICE
BRAND	MODEL	CC	STROKE	ITEM
MBK	Mach G 50	50	2	10294896
MBK	Mach G 50 LC	50	2	10294896
MBK	Nitro *50	50	2	10294896
MBK	Ovetto *50	50	2	10294896
MBK	Rocket	50	2	10294896
MBK	Rocket 50 euro 2	50	2	10294896
MBK	Sorriso *50 2T <-1995	50	2	10294896
MBK	Sorriso *50 2T 1996->	50	2	10294896
MBK	Stunt *50 2T euro 0-1	50	2	10294896
MBK	Stunt *50 2T euro 2	50	2	10294896
MBK	Target *50 2T	50	2	10294896
PIAGGIO	Diesis *50 2T	50	2	10294895
PIAGGIO	Fly *50 2T	50	2	10294895
PIAGGIO	Free *50 2T	50	2	10294895
PIAGGIO	Liberty *50 2T	50	2	10294895
PIAGGIO	NRG *50 LC	50	2	10294895
PIAGGIO	NRG Extreme	50	2	10294895
PIAGGIO	NRG Mc2 LC <-1997	50	2	10294895
PIAGGIO	NRG Mc2 LC 1998->	50	2	10294895
PIAGGIO	NRG Mc3 DD LC	50	2	10294895
PIAGGIO	NRG Mc3 DT	50	2	10294895
PIAGGIO	NRG Power DD LC	50	2	10294895
PIAGGIO	NTT LC	50	2	10294895
PIAGGIO	Quartz LC	50	2	10294895
PIAGGIO	Sfera *50	50	2	10294895
PIAGGIO	Sfera *50 Rst	50	2	10294895
PIAGGIO	Sfera *75	75	2	10294895
PIAGGIO	Typhoon *50 2T 2007->2010	50	2	10294895
PIAGGIO	Typhoon *50 2T euro 2 - 2011->	50	2	10294895
PIAGGIO	Zip *50 2T	50	2	10294895
PIAGGIO	Zip *50 2T / 2000	50	2	10294895
PIAGGIO	Zip Fast Rider	50	2	10294895
PIAGGIO	Zip SP LC ->2000	50	2	10294895
PIAGGIO	Zip SP LC 2001->	50	2	10294895
VESPA	Vespa ET2 *50 - Carburatore	50	2	10294895
VESPA	Vespa ET2 *50- 2000	50	2	10294895
VESPA	Vespa LX *50 2T	50	2	10294895
VESPA	Vespa S (dal 2007)	50	2	10294895
VESPA	Vespa S *50 2T	50	2	10294895
YAMAHA	Aerox *50 euro 0-1	50	2	10294896
YAMAHA	Aerox *50 euro 2	50	2	10294896
YAMAHA	Breeze *50 2T	50	2	10294896
YAMAHA	BW'S *50 euro 0-1	50	2	10294896
YAMAHA	BW'S *50 NG euro 0-1	50	2	10294896
YAMAHA	BW'S *50 NG euro 2	50	2	10294896
YAMAHA	BW'S *50 Original / Naked 2T euro 2 > 2010	50	2	10294896
YAMAHA	CRZ *50 2T	50	2	10294896
YAMAHA	CT *50 2T	50	2	10294896
YAMAHA	Jog *50 R	50	2	10294896
YAMAHA	Jog *50 RR	50	2	10294896
YAMAHA	Neo's *50 2T	50	2	10294896
YAMAHA	Slider *50 2T	50	2	10294896
YAMAHA	Spy *50 2T	50	2	10294896
YAMAHA	Why *50 2T	50	2	10294896
YAMAHA	Zest *50 2T	50	2	10294896
YAMAHA	Zuma *50 2T	50	2	10294896

Impianti di Alimentazione Ø 19-21-22-25 Carburettor Kits Ø 19-21-22-25

Carburatori con diametro da 19 a 25 mm, adatti a tutti gli scooter elaborati. Vengono forniti con tutti gli accessori per il montaggio e già tarati per ogni singolo scooter.

Carburetors from 19 to 25 mm, suitable to all modified scooters. Supplied with all mounting accessories and pre-calibrated for each scooter.



MARCA	MODELLO	CC	TEMPI	Ø 19 mm	Ø 21 mm	Ø 22 mm	Ø 25 mm
BRAND	MODEL	CC	STROKE	Ø 19 mm	Ø 21 mm	Ø 22 mm	Ø 25 mm
APRILIA	Amico *50	50	2	10294951	10294916	-	10294941
APRILIA	Area 51	50	2	10294925	10294954	10294957	10294942
APRILIA	Gulliver *50	50	2	-	10294956	10294957	-
APRILIA	Gulliver *50 LC	50	2	10294925	10294954	10294957	10294942
APRILIA	Habana *50	50	2	10294987	-	-	-
APRILIA	Mojito *50	50	2	10294987	-	-	-
APRILIA	Mojito *50 Custom	50	2	10294952	10294926	10294959	10294940
APRILIA	Rally *50	50	2	10294925	10294954	10294957	-
APRILIA	Rally *50 LC	50	2	10294925	10294954	10294957	10294942
APRILIA	Scarabeo *50 2T	50	2	10294925	10294954	10294957	-
APRILIA	Scarabeo *50 2T Street Carburatore	50	2	10294925	10294954	10294959	10294940
APRILIA	Sonic *50	50	2	10294925	10294954	10294957	10294942
APRILIA	Sonic *50 LC	50	2	10294925	10294954	10294957	10294942
APRILIA	SR *50 <-1993	50	2	10294951	10294916	-	10294941
APRILIA	SR *50 1994->	50	2	10294925	10294954	10294957	10294942
APRILIA	SR *50 2004 / Piaggio Carburatore	50	2	10294952	10294926	10294959	10294940
APRILIA	SR *50 Netscaper LC	50	2	10294925	10294954	10294957	10294942
APRILIA	SR *50 R / Piaggio Carburatore	50	2	10294952	10294926	10294959	10294940
APRILIA	SR *50 Racing LC	50	2	10294925	10294954	10294957	10294942
APRILIA	SR *50 Replica LC	50	2	10294925	10294954	10294957	10294942
APRILIA	SR *50 Replica LC 2000 / Aprilia	50	2	10294986	10294990	-	-
APRILIA	SR *50 Stealth LC	50	2	10294925	10294954	10294957	10294942
APRILIA	SR *50 WWW	50	2	10294925	10294954	10294957	10294942
ATALA	Carosello *50	50	2	10294925	10294954	10294958	-
ATALA	Hacker *50	50	2	-	10294961	-	-
ATALA	Hacker *50 LC	50	2	-	10294961	-	-
BENELLI	491 Gt	50	2	10294925	10294954	10294958	10294942
BENELLI	491 Sport LC	50	2	10294925	10294954	10294957	10294942
BENELLI	K2 *50	50	2	10294925	10294954	10294958	10294942
BENELLI	K2 *50 LC	50	2	10294925	10294954	10294957	10294942
BENELLI	Naked *50	50	2	10294925	10294954	10294958	10294942
BENELLI	Pepe *50	50	2	10294925	10294954	10294958	-

MARCA	MODELLO	CC	TEMPI	Ø 19 mm	Ø 21 mm	Ø 22 mm	Ø 25 mm
BRAND	MODEL	CC	STROKE	Ø 19 mm	Ø 21 mm	Ø 22 mm	Ø 25 mm
BENELLI	Pepe LX *50 euro 2	50	2	10294925	10294954	10294958	10294942
BENELLI	QuattroNove X *50 euro 2	50	2	10294925	10294954	10294958	10294942
BETA	Ark *50	50	2	10294925	10294954	10294958	10294942
BETA	Ark *50 LC	50	2	10294925	10294954	10294957	10294942
BETA	Chrono	50	2	10294925	10294954	10294958	-
BETA	Eikon *50 LC	50	2	10294925	10294954	10294957	10294942
BETA	Quadra	50	2	10294925	10294954	10294958	10294942
BETA	Tempo	50	2	10294925	10294954	10294958	-
BSV	Ax	50	2	10294925	10294954	10294958	-
BSV	Dio Gp	50	2	-	10294923	-	-
BSV	Dio Sp	50	2	10294967	10294930	-	-
BSV	Dio Zx (al 1993)	50	2	10294967	10294930	-	-
BSV	Dio Zx (dal 1994)	50	2	10294967	10294930	-	-
BSV	Gz	50	2	10294925	10294954	10294958	-
CAGIVA	City	50	2	10294969	10294934	-	-
CAGIVA	Progress	50	2	10294952	10294926	-	-
CPI	Aragon GP - Hussar - Oliver - Popcorn 2003 >	50	2	10294925	10294954	10294958	10294942
CPI	Hussar - Oliver - Popcorn < 2002	50	2	10294925	10294954	10294958	-
CPI	Aragon GP - Hussar - Oliver - Popcorn > 2003	50	2	10294925	10294954	10294958	10294942
DERBI	Atlantis *50	50	2	10294952	10294926	-	-
DERBI	Atlantis *50 LC	50	2	10294952	10294926	-	-
DERBI	Bullet *50	50	2	10294952	10294926	10294959	-
DERBI	GP1 *50 LC	50	2	10294952	10294926	10294959	10294940
DERBI	GP1 *50 OPEN	50	2	10294952	10294926	10294959	10294940
DERBI	GP1 *50 REVOLUTION	50	2	10294952	10294926	10294959	10294940
DERBI	Hunter	50	2	10294952	10294926	-	-
DERBI	Paddock *50 LC	50	2	10294952	10294926	-	-
DERBI	Predator *50	50	2	10294952	10294926	-	-
DERBI	Predator *50 LC	50	2	10294952	10294926	-	-
EXPLORER	Cracker *50 2003>	50	2	10294925	10294954	10294958	10294942
FANTIC	Big Wheel *50 2T	50	2	10294951	10294916	-	10294941
GARELLI	Gsp *50	50	2	10294925	10294954	10294957	10294942
GARELLI	Pony *50	50	2	10294951	10294916	-	10294941
GARELLI	Sr *50	50	2	10294951	10294916	-	10294941
GARELLI	Tiesse *50 R	50	2	10294925	10294954	10294958	10294942
GILERA	DNA *50 LC	50	2	10294952	10294926	10294959	10294940
GILERA	Easy Moving	50	2	10294952	10294926	10294959	-
GILERA	Ice *50 2T	50	2	10294952	10294926	10294959	10294940
GILERA	Runner *50 LC < 2005	50	2	10294952	10294926	10294959	10294940
GILERA	Runner *50 SP LC <<2005	50	2	10294952	10294926	10294959	10294940
GILERA	Runner *50 SP LC Carburatore 2006->	50	2	10294952	10294926	10294959	10294940
GILERA	Stalker	50	2	10294952	10294926	10294959	10294940
GILERA	Storm	50	2	10294952	10294926	10294959	10294940
GILERA	Typhoon	50	2	10294952	10294926	10294959	10294940
GILERA	Typhoon *50 X	50	2	10294952	10294926	10294959	10294940
HONDA	Bali *50	50	2	10294974	10294937	-	-
HONDA	Dio G	50	2	-	10294923	-	10294939
HONDA	Dio Sp	50	2	10294967	10294930	-	10294939
HONDA	Dio Sr	50	2	10294967	10294930	-	10294939
HONDA	Dio Zx <-1993	50	2	10294967	10294930	-	10294939
HONDA	Dio Zx 1994->	50	2	10294967	10294930	-	10294939
HONDA	EZ Cub 90	90	2	-	10294936	-	-
HONDA	Lead	50	2	10294972	10294917	-	-
HONDA	SFX *50	50	2	10294967	10294930	-	-
HONDA	SH *50 - 1996->	50	2	10294974	10294937	-	-
HONDA	SH *50 <-1995	50	2	10294978	10294920	-	-
HONDA	Shadow *50	50	2	-	10294923	-	-
HONDA	Sky *50	50	2	10294967	10294930	-	-
HONDA	Sxr	50	2	10294967	10294930	-	-
HONDA	Vision	50	2	-	10294931	-	-
HONDA	Vision Met-In	50	2	-	10294924	-	-
HONDA	X8R X-S	50	2	-	10294923	-	-
HSC	Cub 90 Cc	90	2	-	10294936	-	-
HSC	Sc 01	50	2	10294967	10294930	-	-
HSC	Sc 01L Dio Zx	50	2	10294967	10294930	-	-
HUPPER	Montecarlo 30 2T	50	2	10294925	10294954	10294958	10294942
ITALJET	Bazooka	50	2	10294951	10294916	-	10294941
ITALJET	Dragster *50 LC	50	2	10294925	10294954	10294957	10294942
ITALJET	Formula *50	50	2	10294965	10294935	-	-
ITALJET	Formula *50 LC	50	2	10294965	10294935	-	-
ITALJET	Jet Set *50	50	2	10294952	10294926	10294959	-
ITALJET	Pista	50	2	10294951	10294916	-	10294941

MARCA	MODELLO	CC	TEMPI	Ø 19 mm	Ø 21 mm	Ø 22 mm	Ø 25 mm
BRAND	MODEL	CC	STROKE	Ø 19 mm	Ø 21 mm	Ø 22 mm	Ø 25 mm
ITALJET	Pista 2	50	2	10294951	10294916	-	10294941
ITALJET	Reporter	50	2	10294951	10294916	-	10294941
ITALJET	Scoop	50	2	10294951	10294916	-	10294941
ITALJET	Torpedo *50 2T	50	2	10294965	10294935	-	-
ITALJET	Torpedo *50 2T New	50	2	10294925	10294954	10294959	-
ITALJET	Velocifero	50	2	10294965	10294935	-	-
ITALJET	Yankee	50	2	10294951	10294916	-	10294941
KEEWAY	F-ACT	50	2	10294925	10294954	10294958	10294942
KEEWAY	Goccia	50	2	10294925	10294954	10294958	10294942
KEEWAY	Hurricane	50	2	10294925	10294954	10294958	10294942
KEEWAY	Matrix	50	2	10294925	10294954	10294958	10294942
KEEWAY	Pixel	50	2	10294925	10294954	10294958	10294942
KEEWAY	RY8	50	2	10294925	10294954	10294958	10294942
KYMCO	Dink *50	50	2	-	10294919	-	-
KYMCO	Dink *50 LC	50	2	10294992	10294919	-	-
KYMCO	Dj X	50	2	-	10294924	-	10294939
KYMCO	Dj Y	50	2	-	10294938	-	10294939
KYMCO	Heroism	50	2	-	10294919	-	-
KYMCO	K12	50	2	-	10294931	-	-
KYMCO	People *50	50	2	-	10294919	-	-
KYMCO	Sniper *50 2T	50	2	-	10294919	-	-
KYMCO	Super 9 - *50 LC	50	2	10294992	10294919	-	-
KYMCO	Top Boy - Cobra *50	50	2	-	10294919	-	-
LEM	Flash *50 2T	50	2	10294951	10294916	-	10294941
LEM	Ghibli *50 2T	50	2	10294951	10294916	-	10294941
LEM	Tornado *50 2T	50	2	10294951	10294916	-	10294941
MALAGUTI	Centro *50 2T	50	2	10294925	10294954	10294958	-
MALAGUTI	Ciak *50	50	2	10294925	10294954	10294958	-
MALAGUTI	Crosser CR1	50	2	-	10294961	-	-
MALAGUTI	F10	50	2	10294925	10294954	10294958	10294942
MALAGUTI	F10 Wap	50	2	10294925	10294954	10294958	10294942
MALAGUTI	F12 Digit KAT 50 LC	50	2	10294925	10294954	10294957	10294942
MALAGUTI	F12 Digit KAT 50 LC euro 2	50	2	10294925	10294954	10294957	10294942
MALAGUTI	F12 Phantom *50	50	2	10294925	10294954	10294958	10294942
MALAGUTI	F12 Phantom *50 LC	50	2	10294925	10294954	10294957	10294942
MALAGUTI	F12 R AIR euro 2	50	2	10294925	10294954	10294958	10294942
MALAGUTI	F12 R LC euro 2	50	2	10294925	10294954	10294957	10294942
MALAGUTI	F15 Firefox LC	50	2	10294925	10294954	10294957	10294942
MALAGUTI	Yesterday	50	2	10294925	10294954	10294958	10294942
MBK	Active	50	2	10294921	10294953	-	-
MBK	Booster *50 euro 0-1	50	2	10294951	10294916	-	10294941
MBK	Booster *50 Naked euro 2	50	2	10294951	10294916	-	10294941
MBK	Booster *50 NG euro 0-1	50	2	10294951	10294916	-	10294941
MBK	Booster *50 NG euro 2	50	2	10294951	10294916	-	10294941
MBK	Booster *50 Spirit euro 0-1	50	2	10294951	10294916	-	10294941
MBK	Evollis	50	2	10294925	10294954	10294958	10294942
MBK	Fizz	50	2	10294925	10294954	10294958	10294942
MBK	Flipper	50	2	10294925	10294954	10294958	10294942
MBK	Forte	50	2	10294925	10294954	10294958	10294942
MBK	Hot Champ	50	2	10294984	10294927	10294958	-
MBK	Mach G 50	50	2	10294925	10294954	10294957	10294942
MBK	Mach G 50 LC	50	2	10294925	10294954	10294957	10294942
MBK	Nitro *50	50	2	10294925	10294954	10294957	10294942
MBK	Ovetto *50	50	2	10294925	10294954	10294957	10294942
MBK	Rocket	50	2	10294951	10294916	-	10294941
MBK	Rocket 50 euro 2	50	2	10294951	10294916	-	10294941
MBK	Sorriso *50 2T <-1995	50	2	10294951	10294916	-	10294941
MBK	Sorriso *50 2T 1996->	50	2	10294984	10294927	10294958	10294942
MBK	Stunt *50 2T euro 0-1	50	2	10294951	10294916	-	10294941
MBK	Stunt *50 2T euro 2	50	2	10294951	10294916	-	10294941
MBK	Target *50 2T	50	2	10294951	10294916	-	10294941
P.G.O.	Big Max *50 2T	50	2	-	10294962	-	-
P.G.O.	Comet *50 2T	50	2	-	10294932	-	-
P.G.O.	Star *50 2T	50	2	-	10294928	-	-
P.G.O.	Star II *50 2T	50	2	-	10294932	-	-
PEUGEOT	Buxy - Buxy Rs *50 2T	50	2	10294985	10294943	-	-
PEUGEOT	Elyseo *50 2T	50	2	10294985	10294943	-	-
PEUGEOT	Jet Force C-Tech *50 2T	50	2	-	10294954	-	-
PEUGEOT	Ludix Blaster *50 2T	50	2	-	10294954	-	-
PEUGEOT	Metal-X *50 2T	50	2	10294985	10294943	-	-
PEUGEOT	Metropolis - Sc	50	2	10294972	10294917	-	-
PEUGEOT	Rapido *50 2T	50	2	-	10294931	-	-

MARCA	MODELLO	CC	TEMPI	Ø 19 mm	Ø 21 mm	Ø 22 mm	Ø 25 mm
BRAND	MODEL	CC	STROKE	Ø 19 mm	Ø 21 mm	Ø 22 mm	Ø 25 mm
PEUGEOT	Speedake *50 2T	50	2	10294985	10294943	-	-
PEUGEOT	Speedfight *50 2T	50	2	10294985	10294943	-	-
PEUGEOT	Speedfight *50 2T LC	50	2	10294985	10294943	-	-
PEUGEOT	Speedfight 2 *50 LC 2004->	50	2	10294985	10294943	-	-
PEUGEOT	Squab *50 2T	50	2	10294985	10294943	-	-
PEUGEOT	St *50 2T	50	2	-	10294931	-	-
PEUGEOT	Sv Geo *50 2T	50	2	10294976	10294929	-	-
PEUGEOT	Trekker *50 2T	50	2	10294985	10294943	-	-
PEUGEOT	Vivacity *50 KAT 2T	50	2	10294985	10294943	-	-
PEUGEOT	X-Fight *50 2T	50	2	10294985	10294943	-	-
PEUGEOT	X-Fight *50 2T LC	50	2	10294985	10294943	-	-
PEUGEOT	X-Fight 2 *50 LC 2004->	50	2	10294985	10294943	-	-
PEUGEOT	Zenith *50 2T	50	2	10294985	10294943	-	-
PIAGGIO	Diesis *50 2T	50	2	10294952	10294926	10294959	-
PIAGGIO	Fly *50 2T	50	2	10294952	10294926	10294959	-
PIAGGIO	Free *50 2T	50	2	10294925	10294954	10294959	10294940
PIAGGIO	Liberty *50 2T	50	2	10294925	10294954	10294959	10294940
PIAGGIO	NRG *50 LC	50	2	10294952	10294926	10294959	10294940
PIAGGIO	NRG Extreme	50	2	10294952	10294926	10294959	10294940
PIAGGIO	NRG Extreme LC	50	2	-	-	10294959	10294940
PIAGGIO	NRG Mc2 LC <-1997	50	2	10294952	10294926	10294959	10294940
PIAGGIO	NRG Mc2 LC 1998->	50	2	10294952	10294926	10294959	10294940
PIAGGIO	NRG Mc3 DD LC	50	2	10294952	10294926	10294959	10294940
PIAGGIO	NRG Mc3 DT	50	2	10294952	10294926	10294959	10294940
PIAGGIO	NRG Power DD LC	50	2	10294952	10294926	10294959	10294940
PIAGGIO	NTT LC	50	2	10294952	10294926	10294959	10294940
PIAGGIO	Quartz LC	50	2	10294955	10294933	10294959	10294940
PIAGGIO	Sfera *50	50	2	10294952	10294926	10294959	-
PIAGGIO	Sfera *50 Rst	50	2	10294952	10294926	10294959	10294940
PIAGGIO	Sfera *75	75	2	10294952	10294926	10294959	-
PIAGGIO	Typhoon *50 2T 2007->2010	50	2	10294952	10294926	10294959	10294940
PIAGGIO	Typhoon *50 2T euro 2 - 2011->	50	2	10294952	10294926	10294959	10294940
PIAGGIO	Zip *50 2T	50	2	10294952	10294926	10294959	-
PIAGGIO	Zip *50 2T / 2000	50	2	10294952	10294926	10294959	10294940
PIAGGIO	Zip Fast Rider	50	2	10294952	10294926	10294959	10294940
PIAGGIO	Zip SP LC ->2000	50	2	10294952	10294926	10294959	10294940
PIAGGIO	Zip SP LC 2001->	50	2	10294952	10294926	10294959	10294940
RIZZATO	Vamos	50	2	10294965	10294935	-	-
SUZUKI	Address Ah 50 2T	50	2	10294965	10294935	-	-
SUZUKI	AP *50 2T	50	2	10294965	10294935	-	-
SUZUKI	Estilete - UF 50 2T	50	2	10294986	10294990	-	-
SUZUKI	Katana *50 - 1999->	50	2	10294986	10294990	-	-
SUZUKI	Katana *50 <-1998)	50	2	10294986	10294990	-	-
SUZUKI	Katana *50 LC <-1998	50	2	10294986	10294990	-	-
SUZUKI	Katana *50 LC 1999->	50	2	10294986	10294990	-	-
SUZUKI	Sepia *50 2T	50	2	10294965	10294935	-	-
SUZUKI	Sepia *50 ZZ 2T	50	2	10294965	10294935	-	-
SUZUKI	Street Magic	50	2	10294991	-	-	-
SUZUKI	Zillion *50 2T	50	2	10294986	10294990	-	-
YAMAHA	Aerox *50 euro 0-1	50	2	10294925	10294954	10294957	10294942
YAMAHA	Aerox *50 euro 2	50	2	10294925	10294954	10294957	10294942
YAMAHA	Axis *50 2T	50	2	10294984	10294927	10294958	10294942
YAMAHA	Beluga *50 2T	50	2	10294921	10294953	-	-
YAMAHA	Breeze *50 2T	50	2	10294925	10294954	10294958	10294942
YAMAHA	BW'S *50 euro 0-1	50	2	10294951	10294916	-	10294941
YAMAHA	BW'S *50 NG euro 0-1	50	2	10294951	10294916	-	10294941
YAMAHA	BW'S *50 NG euro 2	50	2	10294951	10294916	-	10294941
YAMAHA	BW'S *50 Original / Naked 2T euro 2 > 2010	50	2	10294951	10294916	-	10294941
YAMAHA	CRZ *50 2T	50	2	10294951	10294916	-	10294941
YAMAHA	CT *50 2T	50	2	10294951	10294916	-	10294941
YAMAHA	Jog *50	50	2	10294984	10294927	10294958	10294942
YAMAHA	Jog *50 ER	50	2	10294984	10294927	10294958	10294942
YAMAHA	Jog *50 R	50	2	10294925	10294954	10294957	10294942
YAMAHA	Jog *50 RR	50	2	10294925	10294954	10294957	10294942
YAMAHA	Jog *50 Z	50	2	10294984	10294927	10294958	-
YAMAHA	Neo's *50 2T	50	2	10294925	10294954	10294957	10294942
YAMAHA	Slider *50 2T	50	2	10294951	10294916	-	10294941
YAMAHA	Spy *50 2T	50	2	10294951	10294916	-	10294941
YAMAHA	Vino *50 2T	50	2	10294984	10294927	10294958	-
YAMAHA	Why *50 2T	50	2	10294925	10294954	10294958	-
YAMAHA	Zest *50 2T	50	2	10294925	10294954	10294958	-
YAMAHA	Zuma *50 2T	50	2	10294951	10294916	-	10294941

Impianti di Alimentazione Maxi Scooter Carburettor Kits for Maxi Scooters

Carburatori con diametro da 19 a 25 mm, adatti a tutti gli scooter elaborati. Vengono forniti con tutti gli accessori per il montaggio e già tarati per ogni singolo scooter.

Carburetors from 19 to 25 mm, suitable to all modified scooters. Supplied with all mounting accessories and pre-calibrated for each scooter.



MARCA	MODELLO	CC	TEMPI	Ø 21 mm	Ø 22 mm	Ø 25 mm
BRAND	MODEL	CC	STROKE	Ø 21 mm	Ø 22 mm	Ø 25 mm
APRILIA	Scarabeo 100 2T	100	2	-	10294989	-
APRILIA	SR 125	125	2	-	-	10294960
APRILIA	SR 150	150	2	-	-	10294960
BENELLI	K2 100	100	2	-	10294989	-
GILERA	Runner FX 125	125	2	-	-	10294960
GILERA	Runner FXR 180	180	2	-	-	10294960
GILERA	Typhoon 125	125	2	-	-	10294960
GILERA	Typhoon 125 X	125	2	-	-	10294960
ITALJET	Dragster 125	125	2	-	-	10294960
ITALJET	Dragster 180	180	2	-	-	10294960
ITALJET	Millennium 100	100	2	-	10294989	-
MALAGUTI	Ciak 100	100	2	10294961	-	-
MALAGUTI	F12 Phantom 100	100	2	10294961	-	-
MBK	Booster 100 2T	100	2	-	10294989	-
MBK	Nitro 100	100	2	-	10294989	-
MBK	Ovetto 100	100	2	-	10294989	-
PIAGGIO	Hexagon 125 2T	125	2	-	-	10294963
PIAGGIO	Hexagon 150 2T	150	2	-	-	10294963
PIAGGIO	Hexagon LX 125 2T	125	2	-	-	10294963
PIAGGIO	Hexagon LXT 180 2T	180	2	-	-	10294963
PIAGGIO	Skipper 125 2T	125	2	-	-	10294960
PIAGGIO	Skipper 150 2T	150	2	-	-	10294960
PIAGGIO	Skipper LX 125	125	2	-	-	10294960
PIAGGIO	Skipper LXT 150	150	2	-	-	10294960
YAMAHA	Aerox 100 2T	100	2	-	10294989	-
YAMAHA	BW'S 100 2T	100	2	-	10294989	-
YAMAHA	Neo's 100 2T	100	2	-	10294989	-

Kit idraulica progressiva per forcelle originali Progressive hydraulic fork kit for original forks

Il kit contiene 2 pompanti ed una coppia di molle progressive. I pompanti sono composti da un pistone dotato di 2 pacchi di valvole lamellari, uno per la frenatura in compressione ed uno per la frenatura in estensione. Il sistema sfrutta la parete interna del tubo di forza come cartuccia idraulica, simulando la frenatura idraulica delle più moderne forcelle da moto.

Con questo sistema, la frenatura idraulica agisce direttamente sulle valvole variando il funzionamento in base alle forze assorbite, garantendo stabilità, confort e maggior sicurezza.

The kit contains 2 hydraulic dampers with a pair of progressive springs. The dampers comprise a piston with two lamellar valve groups, one for compression damping and the other for rebound damping. The system uses the inner wall of the wheel leg as a hydraulic cartridge to simulate the damping action of the latest motorcycle forks. In this system, hydraulic damping is achieved by varying the functioning of the valve groups to match the forces absorbed, thus guaranteeing stability, comfort and greater safety.



MARCA	MODELLO	CC	TEMPI	CODICE
BRAND	MODEL	CC	STROKE	ITEM
HONDA	@125	125	4	-
HONDA	@150	150	4	-
HONDA	Foresight 250	250	4	10442003
HONDA	SH 125	125	4	-
HONDA	SH 150	150	4	-
HONDA	Silver Wing 600	600	4	10442027
KYMCO	B&W 125	125	4	10442023
KYMCO	B&W 150	150	4	10442023
KYMCO	B&W 250	250	4	10442023
KYMCO	Dink 125	125	4	10442009

MARCA	MODELLO	CC	TEMPI	CODICE
BRAND	MODEL	CC	STROKE	ITEM
KYMCO	Dink 150	150	4	10442009
KYMCO	Grand Dink 125	125	4	10442023
KYMCO	Grand Dink 150	150	4	10442023
KYMCO	Grand Dink 250	250	4	10442023
KYMCO	Movie 125 4T	125	4	10442009
MBK	Skyliner 250	250	4	10442002
SUZUKI	Burgman AN 400 4T - K3-K6	400	4	10442016
SUZUKI	Burgman AN 650 4T	650	4	10442000
YAMAHA	Majesty 250 4T	250	4	10442002

➤ Pacco Lamellare POWER VALVE POWER VALVE Kit

Il kit Pinasco PowerValve, per motori Minarelli/Yamaha Orizzontale, inclina il pacco lamellare specifico, maggiorato a doppia lamella in carbonio, verso il cilindro, evitando che i flussi di miscela aria benzina vengano rallentati dall'albero motore, garantendo il massimo rendimento.

Pinasco's POWER VALVE KIT, for horizontal engine Minarelli/Yamaha, inclines the specific tuned reed valve in the direction of the cylinder avoiding to reduce the speed of flux of mix air & fuel because of the crankshaft to offer best performance to your scooter



MARCA	MODELLO	CC	TEMPI	CODICE
BRAND	MODEL	CC	STROKE	ITEM
APRILIA	Area 51	50	2	10381000
APRILIA	Gulliver *50	50	2	10381000
APRILIA	Gulliver *50 LC	50	2	10381000
APRILIA	Rally *50	50	2	10381000
APRILIA	Rally *50 LC	50	2	10381000
APRILIA	Scarabeo *50 2T	50	2	10381000
APRILIA	Sonic *50	50	2	10381000
APRILIA	Sonic *50 LC	50	2	10381000
APRILIA	SR *50 1994->	50	2	10381000
APRILIA	SR *50 Netscaper LC	50	2	10381000
APRILIA	SR *50 Racing LC	50	2	10381000
APRILIA	SR *50 Replica LC	50	2	10381000
APRILIA	SR *50 Stealth LC	50	2	10381000
APRILIA	SR *50 WWW	50	2	10381000
ATALA	Carosello *50	50	2	10381000
BENELLI	491 Gt	50	2	10381000
BENELLI	491 Sport LC	50	2	10381000
BENELLI	K2 *50	50	2	10381000
BENELLI	K2 *50 LC	50	2	10381000
BENELLI	Naked *50	50	2	10381000
BENELLI	Pepe *50	50	2	10381000
BETA	Ark *50	50	2	10381000
BETA	Ark *50 LC	50	2	10381000
BETA	Chrono	50	2	10381000
BETA	Eikon *50 LC	50	2	10381000
BETA	Quadra	50	2	10381000
BETA	Tempo	50	2	10381000
BSV	Ax	50	2	10381000
BSV	Gz	50	2	10381000
CPI	Hussar - Oliver - Popcorn < 2002	50	2	10381000
GARELLI	Gsp *50	50	2	10381000
ITALJET	Dragster *50 LC	50	2	10381000
MALAGUTI	Centro *50 2T	50	2	10381000

MARCA	MODELLO	CC	TEMPI	CODICE
BRAND	MODEL	CC	STROKE	ITEM
MALAGUTI	Ciak *50	50	2	10381000
MALAGUTI	F10	50	2	10381000
MALAGUTI	F12 Digit KAT 50 LC	50	2	10381000
MALAGUTI	F12 Digit KAT 50 LC euro 2	50	2	10381000
MALAGUTI	F12 Phantom *50	50	2	10381000
MALAGUTI	F12 Phantom *50 LC	50	2	10381000
MALAGUTI	F12 R LC euro 2	50	2	10381000
MALAGUTI	F15 Firefox LC	50	2	10381000
MALAGUTI	Yesterday	50	2	10381000
MBK	Evolis	50	2	10381000
MBK	Fizz	50	2	10381000
MBK	Flipper	50	2	10381000
MBK	Forte	50	2	10381000
MBK	Hot Champ	50	2	10381000
MBK	Mach G 50	50	2	10381000
MBK	Mach G 50 LC	50	2	10381000
MBK	Nitro *50	50	2	10381000
MBK	Ovetto *50	50	2	10381000
MBK	Sorriso *50 2T 1996->	50	2	10381000
P.G.O.	Big Max *50 2T	50	2	10381000
YAMAHA	Aerox *50 euro 0-1	50	2	10381000
YAMAHA	Aerox *50 euro 2	50	2	10381000
YAMAHA	Axis *50 2T	50	2	10381000
YAMAHA	Breeze *50 2T	50	2	10381000
YAMAHA	Jog *50	50	2	10381000
YAMAHA	Jog *50 ER	50	2	10381000
YAMAHA	Jog *50 R	50	2	10381000
YAMAHA	Jog *50 RR	50	2	10381000
YAMAHA	Jog *50 Z	50	2	10381000
YAMAHA	Neo's *50 2T	50	2	10381000
YAMAHA	Vino *50 2T	50	2	10381000
YAMAHA	Why *50 2T	50	2	10381000
YAMAHA	Zest *50 2T	50	2	10381000

Pacco Lamellare POWER SPACER POWER SPACER Kit

Il kit Pinasco PowerSpacer, per motori Minarelli/Yamaha Orizzontale, inclina il pacco lamellare verso il cilindro evitando che i flussi di miscela aria benzina vengano rallentati dall'albero motore, garantendo il massimo rendimento.

Pinasco's POWER SPACER KIT, for horizontal engine Minarelli/Yamaha, inclines the original reed valve in the direction of the cylinder avoiding to reduce the speed of flux of mix air & fuel because of the crankshaft to offer best performance



MARCA	MODELLO	CC	TEMPI	CODICE
BRAND	MODEL	CC	STROKE	ITEM
APRILIA	Area 51	50	2	10381500
APRILIA	Gulliver *50	50	2	10381500
APRILIA	Gulliver *50 LC	50	2	10381500
APRILIA	Rally *50	50	2	10381500
APRILIA	Rally *50 LC	50	2	10381500
APRILIA	Scarabeo *50 2T	50	2	10381500
APRILIA	Sonic *50	50	2	10381500
APRILIA	Sonic *50 LC	50	2	10381500
APRILIA	SR *50 1994->	50	2	10381500
APRILIA	SR *50 Netscaper LC	50	2	10381500
APRILIA	SR *50 Racing LC	50	2	10381500
APRILIA	SR *50 Replica LC	50	2	10381500
APRILIA	SR *50 Stealth LC	50	2	10381500
APRILIA	SR *50 WWW	50	2	10381500
ATALA	Carosello *50	50	2	10381500
BENELLI	491 Gt	50	2	10381500
BENELLI	491 Sport LC	50	2	10381500
BENELLI	K2 *50	50	2	10381500
BENELLI	K2 *50 LC	50	2	10381500
BENELLI	Naked *50	50	2	10381500
BENELLI	Pepe *50	50	2	10381500
BETA	Ark *50	50	2	10381500
BETA	Ark *50 LC	50	2	10381500
BETA	Chrono	50	2	10381500
BETA	Eikon *50 LC	50	2	10381500
BETA	Quadra	50	2	10381500
BETA	Tempo	50	2	10381500
BSV	Ax	50	2	10381500
BSV	Gz	50	2	10381500
CPI	Hussar - Oliver - Popcorn < 2002	50	2	10381500
GARELLI	Gsp *50	50	2	10381500
ITALJET	Dragster *50 LC	50	2	10381500
MALAGUTI	Centro *50 2T	50	2	10381500

MARCA	MODELLO	CC	TEMPI	CODICE
BRAND	MODEL	CC	STROKE	ITEM
MALAGUTI	Ciak *50	50	2	10381500
MALAGUTI	F10	50	2	10381500
MALAGUTI	F12 Digit KAT 50 LC	50	2	10381500
MALAGUTI	F12 Digit KAT 50 LC euro 2	50	2	10381500
MALAGUTI	F12 Phantom *50	50	2	10381500
MALAGUTI	F12 Phantom *50 LC	50	2	10381500
MALAGUTI	F12 R LC euro 2	50	2	10381500
MALAGUTI	F15 Firefox LC	50	2	10381500
MALAGUTI	Yesterday	50	2	10381500
MBK	Evolis	50	2	10381500
MBK	Fizz	50	2	10381500
MBK	Flipper	50	2	10381500
MBK	Forte	50	2	10381500
MBK	Hot Champ	50	2	10381500
MBK	Mach G 50	50	2	10381500
MBK	Mach G 50 LC	50	2	10381500
MBK	Nitro *50	50	2	10381500
MBK	Ovetto *50	50	2	10381500
MBK	Sorriso *50 2T 1996->	50	2	10381500
P.G.O.	Big Max *50 2T	50	2	10381500
YAMAHA	Aerox *50 euro 0-1	50	2	10381500
YAMAHA	Aerox *50 euro 2	50	2	10381500
YAMAHA	Axis *50 2T	50	2	10381500
YAMAHA	Breeze *50 2T	50	2	10381500
YAMAHA	Jog *50	50	2	10381500
YAMAHA	Jog *50 ER	50	2	10381500
YAMAHA	Jog *50 R	50	2	10381500
YAMAHA	Jog *50 RR	50	2	10381500
YAMAHA	Jog *50 Z	50	2	10381500
YAMAHA	Neo's *50 2T	50	2	10381500
YAMAHA	Vino *50 2T	50	2	10381500
YAMAHA	Why *50 2T	50	2	10381500
YAMAHA	Zest *50 2T	50	2	10381500



Kit Lamelle per Pacco Lamellare Originale Reed Kits to fit the Original Valve Pack

Realizzate in fibra di carbonio, vengono fornite in diversi spessori a seconda del tipo di elaborazione effettuata e tipo di carburatore impiegato.

Made from carbon fiber in various thicknesses depending on the type of modification and carburettor used.

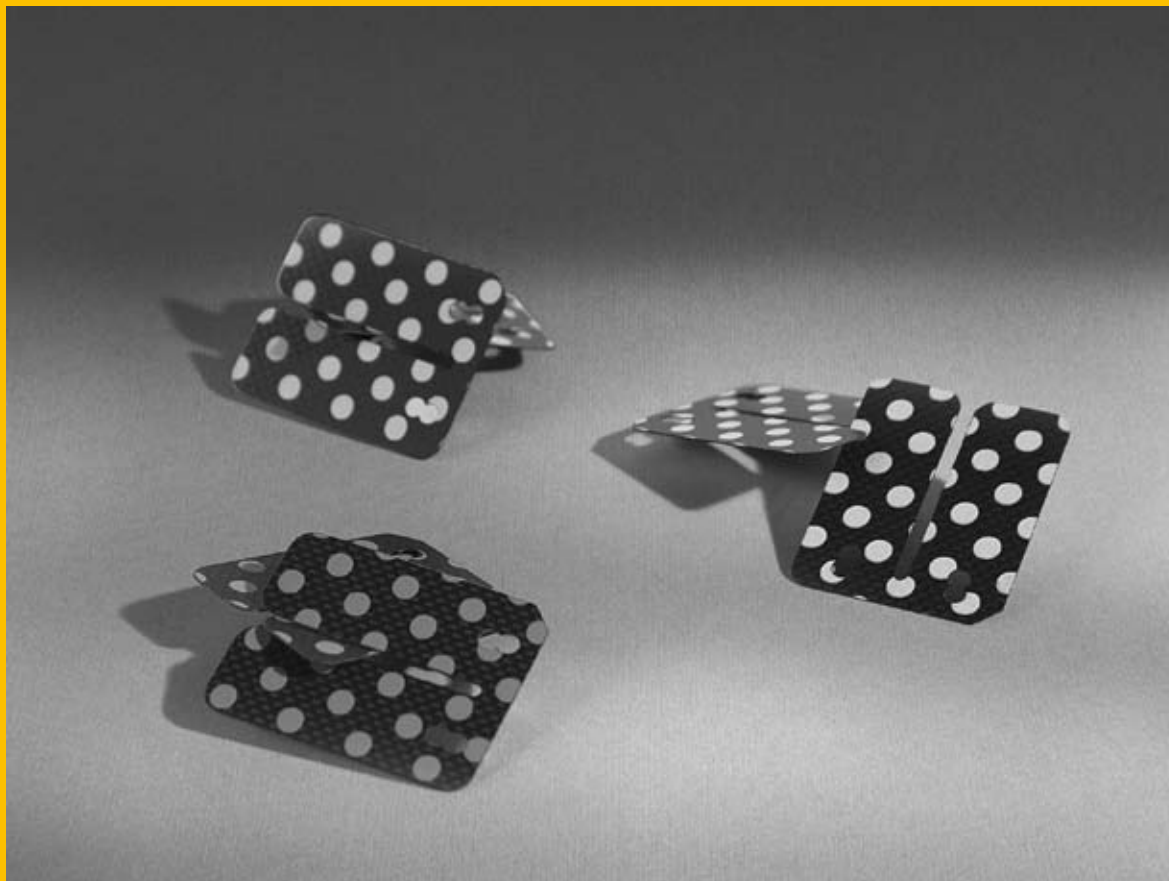

MARCA	MODELLO	CC	TEMPI	CODICE
BRAND	MODEL	CC	STROKE	ITEM
APRILIA	Amico *50	50	2	10387501
APRILIA	Area 51	50	2	10387503
APRILIA	Gulliver *50	50	2	10387503
APRILIA	Gulliver *50 LC	50	2	10387503
APRILIA	Habana *50	50	2	10387503
APRILIA	Mojito *50	50	2	10387503
APRILIA	Mojito *50 Custom	50	2	10387503
APRILIA	Rally *50	50	2	10387503
APRILIA	Rally *50 LC	50	2	10387503
APRILIA	Scarabeo *50 2T	50	2	10387503
APRILIA	Scarabeo *50 2T Street Carburatore	50	2	10387503
APRILIA	Sonic *50	50	2	10387503
APRILIA	Sonic *50 LC	50	2	10387503
APRILIA	SR *50 <-1993	50	2	10387501
APRILIA	SR *50 1994->	50	2	10387503
APRILIA	SR *50 2004 / Piaggio Carburatore	50	2	10387503
APRILIA	SR *50 Netscaper LC	50	2	10387503
APRILIA	SR *50 R / Piaggio Carburatore	50	2	10387503
APRILIA	SR *50 R Factory	50	2	10387503
APRILIA	SR *50 Racing LC	50	2	10387503
APRILIA	SR *50 Replica LC	50	2	10387503
APRILIA	SR *50 Replica LC 2000 / Aprilia	50	2	10387503
APRILIA	SR *50 Stealth LC	50	2	10387503
APRILIA	SR *50 WWW	50	2	10387503
ATALA	Carosello *50	50	2	10387503
ATALA	Hacker *50	50	2	10387418

MARCA	MODELLO	CC	TEMPI	CODICE
BRAND	MODEL	CC	STROKE	ITEM
ATALA	Hacker *50 LC	50	2	10387418
BENELLI	491 Gt	50	2	10387503
BENELLI	491 Sport LC	50	2	10387503
BENELLI	K2 *50	50	2	10387503
BENELLI	K2 *50 LC	50	2	10387503
BENELLI	Naked *50	50	2	10387503
BENELLI	Pepe *50	50	2	10387503
BENELLI	Pepe LX *50 euro 2	50	2	10387503
BENELLI	QuattroNove X *50 euro 2	50	2	10387503
BETA	Ark *50	50	2	10387503
BETA	Ark *50 LC	50	2	10387503
BETA	Chrono	50	2	10387503
BETA	Eikon *50 LC	50	2	10387503
BETA	Quadra	50	2	10387503
BETA	Tempo	50	2	10387503
BSV	Ax	50	2	10387503
BSV	Dio Gp	50	2	10387418
BSV	Dio Sp	50	2	10387418
BSV	Dio Zx (al 1993)	50	2	10387418
BSV	Gz	50	2	10387503
CAGIVA	Progress	50	2	10387418
CPI	Aragon GP - Hussar - Oliver - Popcom 2003 >	50	2	10387503
CPI	Hussar - Oliver - Popcorn < 2002	50	2	10387503
CPI	Aragon GP - Hussar - Oliver - Popcom > 2003	50	2	10387503
DERBI	Atlantis *50	50	2	10387418
DERBI	Atlantis *50 LC	50	2	10387418

MARCA	MODELLO	CC	TEMPI	CODICE
BRAND	MODEL	CC	STROKE	ITEM
DERBI	Bullet *50	50	2	10387503
DERBI	GP1 *50 LC	50	2	10387503
DERBI	GP1 *50 OPEN	50	2	10387503
DERBI	GP1 *50 REVOLUTION	50	2	10387503
DERBI	Hunter	50	2	10387418
DERBI	Paddock *50	50	2	10387418
DERBI	Paddock *50 LC	50	2	10387418
DERBI	Predator *50	50	2	10387418
DERBI	Predator *50 LC	50	2	10387418
EXPLORER	Cracker *50 2003>	50	2	10387503
FANTIC	Big Wheel *50 2T	50	2	10387501
GARELLI	Gsp *50	50	2	10387503
GARELLI	Pony *50	50	2	10387501
GARELLI	Sr *50	50	2	10387501
GARELLI	Tiesse *50 R	50	2	10387503
GILERA	DNA *50 LC	50	2	10387503
GILERA	Easy Moving	50	2	10387503
GILERA	Ice *50 2T	50	2	10387503
GILERA	Runner *50 LC < 2005	50	2	10387503
GILERA	Runner *50 PureJet <-2005	50	2	10387503
GILERA	Runner *50 PureJet 2006->	50	2	10387503
GILERA	Runner *50 SP LC <-2005	50	2	10387503
GILERA	Runner *50 SP LC Carburatore 2006->	50	2	10387503
GILERA	Stalker	50	2	10387503
GILERA	Storm	50	2	10387503
GILERA	Typhoon	50	2	10387503
GILERA	Typhoon *50 X	50	2	10387503
HONDA	Bali *50	50	2	10387418
HONDA	Dio G	50	2	10387418
HONDA	Dio Sp	50	2	10387418
HONDA	Dio Sr	50	2	10387418
HONDA	Dio Zx <-1993	50	2	10387418
HONDA	Lead	50	2	10387412
HONDA	SFX *50	50	2	10387418
HONDA	SH *50 - 1996->	50	2	10387418
HONDA	SH *50 <-1995	50	2	10387412
HONDA	Shadow *50	50	2	10387418
HONDA	Sky *50	50	2	10387418
HONDA	Vision	50	2	10387415
HONDA	Vision Met-In	50	2	10387418
HONDA	X8R X-S	50	2	10387418
HSC	Sc 01	50	2	10387418
HSC	Sc 01L Dio Zx	50	2	10387418
HUPPER	Montecarlo 30 2T	50	2	10387503
ITALJET	Bazooka	50	2	10387501
ITALJET	Dragster *50 LC	50	2	10387503
ITALJET	Formula *50	50	2	10387418
ITALJET	Formula *50 LC	50	2	10387418
ITALJET	Jet Set *50	50	2	10387503
ITALJET	Pista	50	2	10387501
ITALJET	Pista 2	50	2	10387501
ITALJET	Reporter	50	2	10387501
ITALJET	Scoop	50	2	10387501
ITALJET	Torpedo *50 2T New	50	2	10387503
ITALJET	Velocifero	50	2	10387418
ITALJET	Yankee	50	2	10387501
KEEWAY	F-ACT	50	2	10387503
KEEWAY	Goccia	50	2	10387503
KEEWAY	Hurricane	50	2	10387503
KEEWAY	Matrix	50	2	10387503
KEEWAY	Pixel	50	2	10387503
KEEWAY	RY8	50	2	10387503
KYMCO	Dink *50 LC	50	2	10387503

MARCA	MODELLO	CC	TEMPI	CODICE
BRAND	MODEL	CC	STROKE	ITEM
KYMCO	Dj X	50	2	10387418
KYMCO	Dj Y	50	2	10387418
KYMCO	K12	50	2	10387418
KYMCO	Super 9 - *50 LC	50	2	10387503
LEM	Flash *50 2T	50	2	10387501
LEM	Ghibli *50 2T	50	2	10387501
LEM	Tornado *50 2T	50	2	10387501
MALAGUTI	Centro *50 2T	50	2	10387503
MALAGUTI	Ciak *50	50	2	10387503
MALAGUTI	Crosser CR1	50	2	10387418
MALAGUTI	F10	50	2	10387503
MALAGUTI	F10 Wap	50	2	10387503
MALAGUTI	F12 Digit KAT 50 LC	50	2	10387503
MALAGUTI	F12 Digit KAT 50 LC euro 2	50	2	10387503
MALAGUTI	F12 Phantom *50	50	2	10387503
MALAGUTI	F12 Phantom *50 LC	50	2	10387503
MALAGUTI	F12 R AIR euro 2	50	2	10387503
MALAGUTI	F12 R LC euro 2	50	2	10387503
MALAGUTI	F15 Firefox LC	50	2	10387503
MALAGUTI	Yesterday	50	2	10387503
MBK	Active	50	2	10387501
MBK	Booster *50 euro 0-1	50	2	10387501
MBK	Booster *50 Naked euro 2	50	2	10387501
MBK	Booster *50 NG euro 0-1	50	2	10387501
MBK	Booster *50 NG euro 2	50	2	10387501
MBK	Booster *50 Spirit euro 0-1	50	2	10387501
MBK	Evolis	50	2	10387503
MBK	Fizz	50	2	10387503
MBK	Flipper	50	2	10387503
MBK	Forte	50	2	10387503
MBK	Hot Champ	50	2	10387503
MBK	Mach G 50	50	2	10387503
MBK	Mach G 50 LC	50	2	10387503
MBK	Nitro *50	50	2	10387503
MBK	Ovetto *50	50	2	10387503
MBK	Rocket	50	2	10387501
MBK	Rocket 50 euro 2	50	2	10387501
MBK	Sorriso *50 2T <-1995	50	2	10387501
MBK	Sorriso *50 2T 1996->	50	2	10387503
MBK	Stunt *50 2T euro 0-1	50	2	10387501
MBK	Stunt *50 2T euro 2	50	2	10387501
MBK	Target *50 2T	50	2	10387501
P.G.O.	Big Max *50 2T	50	2	10387503
P.G.O.	Comet *50 2T	50	2	10387501
P.G.O.	Star II *50 2T	50	2	10387501
PEUGEOT	Buxy - Buxy Rs *50 2T	50	2	10387418
PEUGEOT	Elyseo *50 2T	50	2	10387418
PEUGEOT	Ludix *50 2T	50	2	10387503
PEUGEOT	Metal-X *50 2T	50	2	10387418
PEUGEOT	Metropolis - Sc	50	2	10387412
PEUGEOT	Rapido *50 2T	50	2	10387415
PEUGEOT	Speedake *50 2T	50	2	10387418
PEUGEOT	Speedfight *50 2T	50	2	10387418
PEUGEOT	Speedfight *50 2T LC	50	2	10387418
PEUGEOT	Speedfight 2 *50 LC 2004->	50	2	10387418
PEUGEOT	Squab *50 2T	50	2	10387418
PEUGEOT	St *50 2T	50	2	10387415
PEUGEOT	Sv Geo *50 2T	50	2	10387418
PEUGEOT	Trekker *50 2T	50	2	10387418
PEUGEOT	Vivacity *50 KAT 2T	50	2	10387418
PEUGEOT	X-Fight *50 2T	50	2	10387418
PEUGEOT	X-Fight *50 2T LC	50	2	10387418
PEUGEOT	X-Fight 2 *50 LC 2004->	50	2	10387418

MARCA	MODELLO	CC	TEMPI	CODICE
BRAND	MODEL	CC	STROKE	ITEM
PEUGEOT	Zenith *50 2T	50	2	10387418
PIAGGIO	Diesis *50 2T	50	2	10387503
PIAGGIO	Fly *50 2T	50	2	10387503
PIAGGIO	Free *50 2T	50	2	10387503
PIAGGIO	Liberty *50 2T	50	2	10387503
PIAGGIO	NRG *50 LC	50	2	10387503
PIAGGIO	NRG Extreme	50	2	10387503
PIAGGIO	NRG Extreme LC	50	2	10387503
PIAGGIO	NRG Mc2 LC <-1997	50	2	10387503
PIAGGIO	NRG Mc2 LC 1998->	50	2	10387503
PIAGGIO	NRG Mc3 DD LC	50	2	10387503
PIAGGIO	NRG Mc3 DT	50	2	10387503
PIAGGIO	NRG Power DD LC	50	2	10387503
PIAGGIO	NRG Power DT LC	50	2	10387503
PIAGGIO	NRG Power PureJet	50	2	10387503
PIAGGIO	NTT LC	50	2	10387503
PIAGGIO	Quartz LC	50	2	10387503
PIAGGIO	Sfera *50	50	2	10387503
PIAGGIO	Sfera *50 Rst	50	2	10387503
PIAGGIO	Sfera *75	75	2	10387503
PIAGGIO	Typhoon *50 2T 2007->2010	50	2	10387503
PIAGGIO	Typhoon *50 2T euro 2 - 2011->	50	2	10387503
PIAGGIO	Zip *50 2T	50	2	10387503
PIAGGIO	Zip *50 2T / 2000	50	2	10387503
PIAGGIO	Zip Fast Rider	50	2	10387503
PIAGGIO	Zip SP LC ->2000	50	2	10387503
PIAGGIO	Zip SP LC 2001->	50	2	10387503
RIZZATO	Vamos	50	2	10387418
SUZUKI	Address Ah 50 2T	50	2	10387418
SUZUKI	AP *50 2T	50	2	10387418
SUZUKI	Estilite - UF 50 2T	50	2	10387503
SUZUKI	Katana *50 - 1999->	50	2	10387503
SUZUKI	Katana *50 <-1998)	50	2	10387503
SUZUKI	Katana *50 LC <-1998	50	2	10387503
SUZUKI	Katana *50 LC 1999->	50	2	10387503
SUZUKI	Sepia *50 2T	50	2	10387418
SUZUKI	Sepia *50 ZZ 2T	50	2	10387418
SUZUKI	Street Magic	50	2	10387503
SUZUKI	Zillion *50 2T	50	2	10387503
SYM	DD *50 2T	50	2	10387418
YAMAHA	Aerox *50 euro 0-1	50	2	10387503
YAMAHA	Aerox *50 euro 2	50	2	10387503
YAMAHA	Axis *50 2T	50	2	10387503
YAMAHA	Beluga *50 2T	50	2	10387501
YAMAHA	Breeze *50 2T	50	2	10387503
YAMAHA	BW'S *50 euro 0-1	50	2	10387501
YAMAHA	BW'S *50 NG euro 0-1	50	2	10387501
YAMAHA	BW'S *50 NG euro 2	50	2	10387501
YAMAHA	BW'S *50 Original / Naked 2T euro 2 > 2010	50	2	10387501
YAMAHA	CRZ *50 2T	50	2	10387501
YAMAHA	CT *50 2T	50	2	10387501
YAMAHA	Jog *50	50	2	10387503
YAMAHA	Jog *50 ER	50	2	10387503
YAMAHA	Jog *50 R	50	2	10387503
YAMAHA	Jog *50 RR	50	2	10387503
YAMAHA	Jog *50 Z	50	2	10387503
YAMAHA	Neo's *50 2T	50	2	10387503
YAMAHA	Slider *50 2T	50	2	10387501
YAMAHA	Spy *50 2T	50	2	10387501
YAMAHA	Vino *50 2T	50	2	10387503
YAMAHA	Why *50 2T	50	2	10387503
YAMAHA	Zest *50 2T	50	2	10387503
YAMAHA	Zuma *50 2T	50	2	10387501

Maxi Scooters

MARCA	MODELLO	CC	TEMPI	CODICE
BRAND	MODEL	CC	STROKE	ITEM
APRILIA	Scarabeo 100 2T	100	2	10387503
APRILIA	SR 125	125	2	10387503
APRILIA	SR 150	150	2	10387503
BENELLI	K2 100	100	2	10387503
GILERA	Runner FX 125	125	2	10387503
GILERA	Runner FXR 180	180	2	10387503
GILERA	Typhoon 125	125	2	10387503
ITALJET	Dragster 125	125	2	10387503
ITALJET	Dragster 180	180	2	10387503
MBK	Booster 100 2T	100	2	10387503
MBK	Ovetto 100	100	2	10387503
PIAGGIO	Hexagon 125 2T	125	2	10387503
PIAGGIO	Hexagon 150 2T	150	2	10387503
PIAGGIO	Hexagon LX 125 2T	125	2	10387503
PIAGGIO	Hexagon LXT 180 2T	180	2	10387503
PIAGGIO	Skipper 125 2T	125	2	10387503
PIAGGIO	Skipper 150 2T	150	2	10387503
PIAGGIO	Skipper LX 125	125	2	10387503
PIAGGIO	Skipper LXT 150	150	2	10387503
YAMAHA	Aerox 100 2T	100	2	10387503
YAMAHA	BW'S 100 2T	100	2	10387503
YAMAHA	Neo's 100 2T	100	2	10387503

Variatori OVERDRIVE Speed Variator OVERDRIVE

Frutto della raffinata tecnologia Pinasco, questi variatori permettono di incrementare l'escursione complessiva rispetto ai componenti di serie, migliorando notevolmente la funzionalità e le prestazioni degli scooter. Disponibili per tutti gli scooter da 50 a 500 cc.

The fruit of Pinasco technology, these variators extend the overall operating range compared to OEM components, resulting in substantial improvement to the functionality and performance of the scooters. They are available for scooters from 50 to 500 cc.

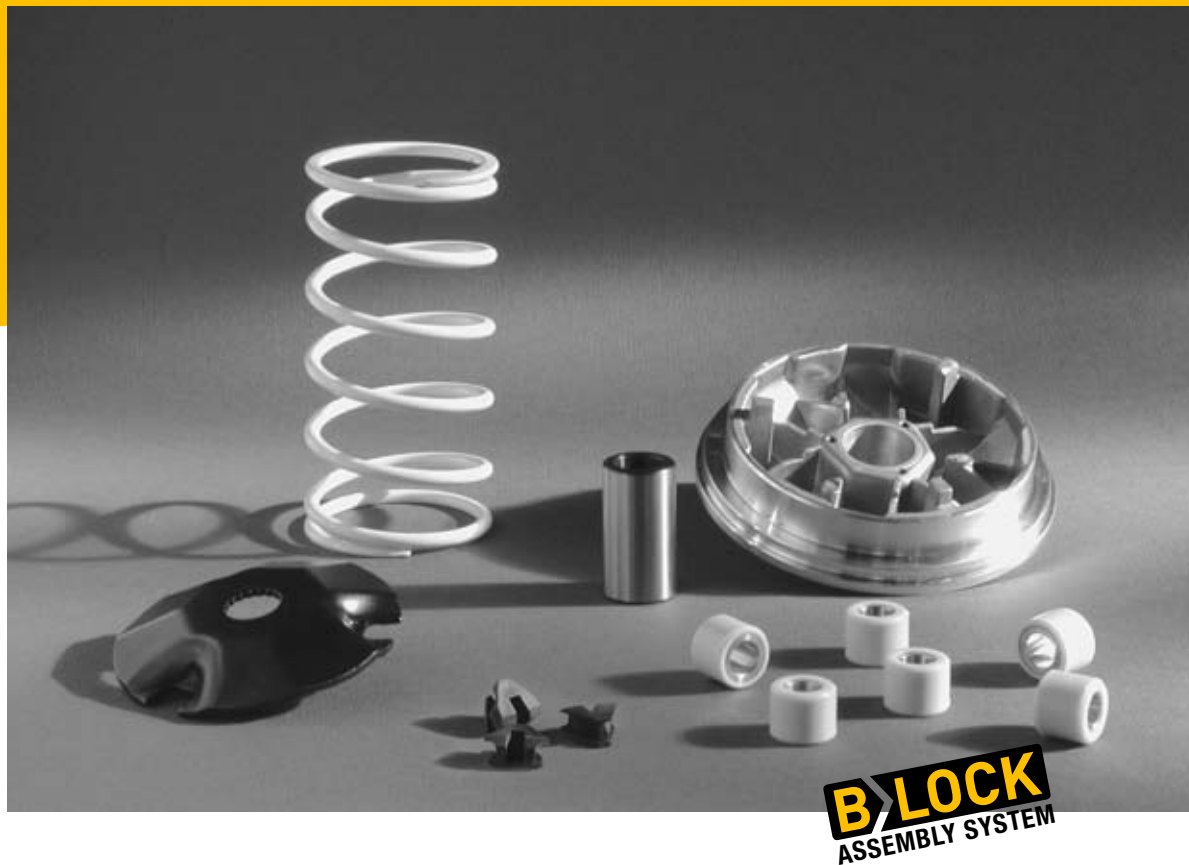

B-LOCK è l'esclusivo sistema di montaggio della bronzina di scorrimento mozzo variatore, principalmente sui variatori per maxi scooter, effettuato senza nessun tipo di deformazione della stessa. Con l'impiego di questa tecnologia, oltre ad avere un perfetto accoppiamento senza rischi di rottura o fuoriuscita, la bronzina mantiene le sue dimensioni iniziali, garantendo costanza di prestazioni a caldo e nell'uso intensivo, assicurando una durata nel tempo superiore anche a quella dei variatori originali.

***B-LOCK** is the unique assembly system of variator bush, mainly on variators for maxi scooter, performed without any deformation. Using this technology, besides having a perfect coupling without risk of breakage or leakage, the bush keeps its own dimension, ensuring constant performance in hot and intensive use, as well as a superior durability even to the original variators.*

MARCA	MODELLO	CC	TEMPI	OVERDRIVE	OVERDRIVE RULLI 019
BRAND	MODEL	CC	STROKE	OVERDRIVE	OVERDRIVE ROLLERS 019
APRILIA	Amico *50	50	2	10260231	10260218
APRILIA	Area 51	50	2	10260231	10260218
APRILIA	Atlantic - Arrecife 125	125	4	10260319	-
APRILIA	Atlantic - Arrecife 250	250	4	10260329	-
APRILIA	Atlantic 200	200	4	10260329	-
APRILIA	Atlantic 500 / 6 rulli	500	4	10260333	-
APRILIA	Atlantic Sprint - Arrecife 250	250	4	10260329	-
APRILIA	Atlantic Sprint - Arrecife 400	400	4	10260402	-
APRILIA	Atlantic Sprint - Arrecife 500	500	4	10260402	-
APRILIA	Gulliver *50	50	2	10260231	10260218
APRILIA	Gulliver *50 LC	50	2	10260231	10260218
APRILIA	Habana *50	50	2	10260252	-
APRILIA	Habana 125	125	4	10260301	-
APRILIA	Leonardo 125	125	4	10260306	-
APRILIA	Leonardo 150	150	4	10260306	-
APRILIA	Leonardo 150 ST	150	4	10260306	-
APRILIA	Leonardo 250	250	4	10260302	-
APRILIA	Leonardo 300	300	4	10260302	-
APRILIA	Mojito *50	50	2	10260252	-
APRILIA	Mojito *50 Custom	50	2	10260254	10260254
APRILIA	Mojito 125	125	4	10260301	-
APRILIA	Mojito 125 RY (Leader)	125	4	10260319	-
APRILIA	Rally *50	50	2	10260231	10260218

MARCA	MODELLO	CC	TEMPI	OVERDRIVE	OVERDRIVE RULLI 019
BRAND	MODEL	CC	STROKE	OVERDRIVE	OVERDRIVE ROLLERS 019
APRILIA	Rally *50 LC	50	2	10260231	10260218
APRILIA	Scarabeo *50 2T	50	2	10260231	10260218
APRILIA	Scarabeo *50 2T Street Carburatore	50	2	10260254	10260254
APRILIA	Scarabeo *50 4T	50	4	10260256	10260256
APRILIA	Scarabeo *50 4T - 4V	50	4	10260256	-
APRILIA	Scarabeo *50 4T Street	50	4	10260256	10260256
APRILIA	Scarabeo *50 DiTech / Aprilia	50	2	10260253	-
APRILIA	Scarabeo 100 2T	100	2	10260315	-
APRILIA	Scarabeo 100 4T	100	4	10260330	-
APRILIA	Scarabeo 125	125	4	10260306	-
APRILIA	Scarabeo 125	125	4	10260319	-
APRILIA	Scarabeo 150	150	4	10260306	-
APRILIA	Scarabeo 200	200	4	10260331	-
APRILIA	Scarabeo 250	250	4	10260329	-
APRILIA	Scarabeo 500 / 6 rulli	500	4	10260333	-
APRILIA	Scarabeo Light 125	125	4	10260319	-
APRILIA	Scarabeo Light 200	200	4	10260329	-
APRILIA	Scarabeo Light 250 i.e. (dal 2007)	250	4	10260329	-
APRILIA	Scarabeo Light 400 i.e.	400	4	10260402	-
APRILIA	Scarabeo Light 500 i.e.	500	4	10260402	-
APRILIA	Scarabeo Special 300 i.e.	300	4	10260329	-
APRILIA	Sonic *50	50	2	10260231	10260218
APRILIA	Sonic *50 LC	50	2	10260231	10260218

BLOCK
 ASSEMBLY SYSTEM

MARCA	MODELLO	CC	TEMPI	OVERDRIVE	OVERDRIVE RULLI 019	MARCA	MODELLO	CC	TEMPI	OVERDRIVE	OVERDRIVE RULLI 019
BRAND	MODEL	CC	STROKE	OVERDRIVE	OVERDRIVE ROLLERS 019	BRAND	MODEL	CC	STROKE	OVERDRIVE	OVERDRIVE ROLLERS 019
APRILIA	Sportcity 125	125	4	10260319	-	DERBI	Boulevard 200	200	4	10260329	-
APRILIA	Sportcity 200	200	4	10260329	-	DERBI	Bullet *50	50	2	10260254	10260254
APRILIA	Sportcity 250 i.e. euro 3	250	4	10260329	-	DERBI	GP1 *50 LC	50	2	10260254	10260254
APRILIA	Sportcity Cube 300 i.e.	300	4	10260329	-	DERBI	GP1 *50 OPEN	50	2	10260254	10260254
APRILIA	Sportcity One *50 4T	50	4	10260256	10260256	DERBI	GP1 *50 REVOLUTION	50	2	10260254	10260254
APRILIA	Sportcity One 125 4t	125	4	10260319	-	DERBI	GP1 125 LC	125	4	10260319	-
APRILIA	SR *50 <-1993	50	2	10260231	10260218	DERBI	GP1 250 LC	250	4	10260329	-
APRILIA	SR *50 1994->	50	2	10260231	10260218	DERBI	Hunter	50	2	10260251	-
APRILIA	SR *50 2004 / Piaggio Carburatore	50	2	10260254	10260254	DERBI	Paddock *50	50	2	10260251	-
APRILIA	SR *50 DiTech / Aprilia	50	2	10260253	-	DERBI	Paddock *50 LC	50	2	10260251	-
APRILIA	SR *50 DiTech GP1 / Piaggio Iniezione	50	2	10260254	10260254	DERBI	Predator *50	50	2	10260251	-
APRILIA	SR *50 Netscaper LC	50	2	10260231	10260218	DERBI	Predator *50 LC	50	2	10260251	-
APRILIA	SR *50 R / Piaggio Carburatore	50	2	10260254	10260254	DERBI	Rambla 125	125	4	10260319	-
APRILIA	SR *50 R Factory	50	2	10260254	10260254	DERBI	Rambla 250	250	4	10260329	-
APRILIA	SR *50 Racing LC	50	2	10260231	10260218	DERBI	Rambla 300	300	4	10260329	-
APRILIA	SR *50 Replica LC	50	2	10260231	10260218	EXPLORER	Cracker *50 2003>	50	2	10260219	-
APRILIA	SR *50 Replica LC 2000 / Aprilia	50	2	10260253	-	FANTIC	Big Wheel *50 2T	50	2	10260231	10260218
APRILIA	SR *50 Stealth LC	50	2	10260231	10260218	GARELLI	Flexi' *50 4T	50	4	10260412	-
APRILIA	SR *50 WWW	50	2	10260231	10260218	GARELLI	Gsp *50	50	2	10260231	10260218
APRILIA	SR 125	125	2	10260307	-	GARELLI	Pony *50	50	2	10260210	-
APRILIA	SR 150	150	2	10260307	-	GARELLI	Sr *50	50	2	10260231	10260218
APRILIA	SR Max 125 i.e.	125	4	10260319	-	GARELLI	Tiesse *50 R	50	2	10260219	-
APRILIA	SR Max 300 i.e.	300	4	10260329	-	GARELLI	Tiesse Four *50	50	4	10260412	-
APRILIA	SR Motard 125	125	4	10260319	-	GARELLI	Xo' 125 i.e.	125	4	10260430	-
ATALA	Carosello *50	50	2	10260231	10260218	GARELLI	Xo' 150 i.e.	150	4	10260430	-
ATALA	Hacker *50	50	2	10260250	-	GILERA	DNA *50 LC	50	2	10260254	10260254
ATALA	Hacker *50 LC	50	2	10260250	-	GILERA	DNA 125	125	4	10260319	-
BAOTIAN	ECO BIKE 50	50	4	10260412	-	GILERA	DNA 180	180	4	10260325	-
BAOTIAN	REBEL - ROCKY - TANCO 9/12 - 50	50	4	10260412	-	GILERA	Easy Moving	50	2	10260255	-
BENELLI	491 Gt	50	2	10260231	10260218	GILERA	Fuoco 500 i.e.	500	4	10260402	-
BENELLI	491 Sport LC	50	2	10260231	10260218	GILERA	Ice *50 2T	50	2	10260254	10260254
BENELLI	Adiva 125	125	4	10260319	-	GILERA	Nexus 125 euro 3	125	4	10260319	-
BENELLI	Adiva 150	150	4	10260319	-	GILERA	Nexus 125 i.e. euro 3	125	4	10260319	-
BENELLI	Adiva AD 250	250	4	10260329	-	GILERA	Nexus 250 i.e. euro 3	250	4	10260329	-
BENELLI	K2 *50	50	2	10260231	10260218	GILERA	Nexus 300 i.e.	300	4	10260329	-
BENELLI	K2 *50 LC	50	2	10260231	10260218	GILERA	Nexus 500 / 6 rulli	500	4	10260333	-
BENELLI	K2 100	100	2	10260315	-	GILERA	Nexus 500 / 8 rulli	500	4	10260402	-
BENELLI	Naked *50	50	2	10260231	10260218	GILERA	Runner *50 LC < 2005	50	2	10260275	10260254
BENELLI	Pepe *50	50	2	10260231	10260218	GILERA	Runner *50 PureJet <-2005	50	2	10260254	10260254
BENELLI	Pepe LX *50 euro 2	50	2	10260219	-	GILERA	Runner *50 PureJet 2006->	50	2	10260254	10260254
BENELLI	QuattroNove X *50 euro 2	50	2	10260219	-	GILERA	Runner *50 SP LC <-2005	50	2	10260275	10260254
BENELLI	Velvet 125	125	4	10260308	-	GILERA	Runner *50 SP LC Carburatore 2006->	50	2	10260254	10260254
BENELLI	Velvet 150	150	4	10260308	-	GILERA	Runner FX 125	125	2	10260307	-
BENELLI	Velvet 250	250	4	10260302	-	GILERA	Runner FXR 180	180	2	10260307	-
BENELLI	Velvet 400	400	4	10260316	-	GILERA	Runner ST 125 4T	125	4	10260329	-
BENELLI	Velvet 400 Dusk	400	4	10260316	-	GILERA	Runner ST 200 4T	200	4	10260329	-
BETA	Ark *50	50	2	10260231	10260218	GILERA	Runner VX 125 <-2005	125	4	10260319	-
BETA	Ark *50 LC	50	2	10260231	10260218	GILERA	Runner VX 125 2006->	125	4	10260319	-
BETA	Chrono	50	2	10260231	10260218	GILERA	Runner VXR 180	180	4	10260325	-
BETA	Eikon *50 LC	50	2	10260231	10260218	GILERA	Runner VXR 200 - 2006->	200	4	10260329	-
BETA	Eikon 125	125	4	10260309	-	GILERA	Runner VXR 200 <-2005	200	4	10260329	-
BETA	Eikon 150	150	4	10260309	-	GILERA	Stalker	50	2	10260275	10260254
BETA	Quadra	50	2	10260231	10260218	GILERA	Storm	50	2	10260255	-
BETA	Tempo	50	2	10260231	10260218	GILERA	Typhoon	50	2	10260255	-
BSV	Ax	50	2	10260231	10260218	GILERA	Typhoon *50 X	50	2	10260275	10260254
BSV	Dio Sr	50	2	10260220	-	GILERA	Typhoon 125	125	2	10260307	-
BSV	Dio Zx (al 1993)	50	2	10260260	-	GILERA	Typhoon 125 X	125	2	10260307	-
BSV	Dio Zx (dal 1994)	50	2	10260260	-	HONDA	@125	125	4	10260321	-
BSV	Gz	50	2	10260231	10260218	HONDA	@150	150	4	10260321	-
CAGIVA	Progress	50	2	10260251	-	HONDA	Bali *50	50	2	10260245	-
CPI	Aragon GP - Hussar - Oliver - Popcorn 2003 >	50	2	10260219	-	HONDA	Bali 100	100	2	10260314	-
CPI	Hussar - Oliver - Popcorn < 2002	50	2	10260219	-	HONDA	CN 250	250	4	10260305	-
CPI	Aragon GP - Hussar - Oliver - Popcorn > 2003	50	2	10260219	-	HONDA	Dio Clean 4 You	50	4	10260257	-
DERBI	Atlantis *50	50	2	10260251	-	HONDA	Dio Zx <-1993	50	2	10260260	-
DERBI	Atlantis *50 LC	50	2	10260251	-	HONDA	Dio Zx 1994->	50	2	10260260	-
DERBI	Boulevard 125	125	4	10260319	-	HONDA	Dylan 125	125	4	10260321	-
DERBI	Boulevard 150	150	4	10260319	-	HONDA	Dylan 150	150	4	10260321	-



MARCA	MODELLO	CC	TEMPI	OVERDRIVE	OVERDRIVE RULLI Ø19	MARCA	MODELLO	CC	TEMPI	OVERDRIVE	OVERDRIVE RULLI Ø19
BRAND	MODEL	CC	STROKE	OVERDRIVE	OVERDRIVE ROLLERS Ø19	BRAND	MODEL	CC	STROKE	OVERDRIVE	OVERDRIVE ROLLERS Ø19
HONDA	Foresight 250	250	4	10260303	-	KEEWAY	F-ACT	50	2	10260219	-
HONDA	Forza 250 - 2001->	250	4	10260322	-	KEEWAY	Goccia	50	2	10260219	-
HONDA	Forza 300 ABS i.e.	300	4	10260404	-	KEEWAY	Hurricane	50	2	10260219	-
HONDA	Forza X 250 <-2007	250	4	10260403	-	KEEWAY	Logik 125 euro 3	125	4	10260321	-
HONDA	Jazz 250 - 2001->	250	4	10260322	-	KEEWAY	Matrix	50	2	10260219	-
HONDA	Pantheon 125	125	2	10260304	-	KEEWAY	Outlook 125 4T	125	4	10260321	-
HONDA	Pantheon 125 4T i.e.	125	4	10260321	-	KEEWAY	Outlook 150 4T	150	4	10260321	-
HONDA	Pantheon 150	150	2	10260304	-	KEEWAY	Pixel	50	2	10260219	-
HONDA	Pantheon 150 4T i.e.	150	4	10260321	-	KEEWAY	RY8	50	2	10260219	-
HONDA	PCX 125 i.e.	125	4	10260433	-	KEEWAY	Zahara 125 euro 3	125	4	10260432	-
HONDA	PCX 125 i.e. euro 3 < 2011	125	4	10260440	-	KYMCO	Agility 125 euro 3	125	4	10260432	-
HONDA	PCX 125 i.e. euro 3 > 2012	125	4	10260440	-	KYMCO	Agility 150 euro 3	150	4	10260432	-
HONDA	PCX 150 i.e. euro 3	150	4	10260440	-	KYMCO	Agility R10/12 - RS *50 2T	50	4	10260420	-
HONDA	PS 125 i.e.	125	4	10260321	-	KYMCO	Agility R16 - RS *50 4T	50	4	10260420	-
HONDA	PS 150 i.e.	150	4	10260321	-	KYMCO	Agility R16 *50 2T	50	2	10260261	-
HONDA	Reflex 250 > 2001	250	4	10260322	-	KYMCO	Agility R16 125 euro 3	125	4	10260432	-
HONDA	SFX *50	50	2	10260245	-	KYMCO	Agility R16 150 euro 3	150	4	10260432	-
HONDA	SH *50 - 1996->	50	2	10260245	-	KYMCO	Agility R16 i 200 euro 3	200	4	10260432	-
HONDA	SH 100	100	2	10260314	-	KYMCO	Agility RS 125 euro 3	125	4	10260432	-
HONDA	SH 125	125	4	10260321	-	KYMCO	B&W 125	125	4	10260309	-
HONDA	SH 125 i.e.	125	4	10260321	-	KYMCO	B&W 150	150	4	10260309	-
HONDA	SH 125 i.e. 2009->	125	4	10260321	-	KYMCO	B&W 250	250	4	10260323	-
HONDA	SH 125 Mode i.e. euro 3	125	4	10260440	-	KYMCO	CX	50	2	10260260	-
HONDA	SH 150	150	4	10260321	-	KYMCO	Dink *50	50	2	10260261	-
HONDA	SH 150 i.e.	150	4	10260321	-	KYMCO	Dink *50 4T	50	4	10260420	-
HONDA	SH 150 i.e. 2009->	150	4	10260321	-	KYMCO	Dink *50 LC	50	2	10260261	-
HONDA	SH 300 i.e. <-2010	300	4	10260404	-	KYMCO	Dink 125	125	4	10260309	-
HONDA	SH 300 i.e. 2011->	300	4	10260404	-	KYMCO	Dink 150	150	4	10260309	-
HONDA	Shadow *50	50	2	10260245	-	KYMCO	Dink 200	200	4	10260309	-
HONDA	SH-I 125 ABS i.e. 2013 euro 3	125	4	10260442	-	KYMCO	Dink DD 200 i.e.	200	4	10260309	-
HONDA	SH-I 150 ABS i.e. 2013 euro 3	150	4	10260442	-	KYMCO	Dink Street 125 i.e.	125	4	10260429	-
HONDA	Sky *50	50	2	10260245	-	KYMCO	Dink Street 200 i.e.	200	4	10260426	-
HONDA	S-Wing 125 euro 3	125	4	10260321	-	KYMCO	Dink Street 300 i.e.	300	4	10260426	-
HONDA	S-Wing 150 euro 3	150	4	10260321	-	KYMCO	Dink Street 300 i.e. 2012->	300	4	10260434	-
HONDA	SW-T 400 euro 3	400	4	10260413	-	KYMCO	Dj Y	50	2	10260260	-
HONDA	Sxr	50	2	10260245	-	KYMCO	Downtown 125 i.e.	125	4	10260429	-
HONDA	Vision 110 i.e.	110	4	10260435	-	KYMCO	Downtown 200 i.e.	200	4	10260426	-
HONDA	X8R X-S	50	2	10260245	-	KYMCO	Downtown 300 i.e.	300	4	10260426	-
HONDA	Zoomer - Ruckus I.E.	50	4	10260257	-	KYMCO	Downtown 300 i.e. 2012->	300	4	10260434	-
HSC	Sc 01L Dio 2x	50	2	10260260	-	KYMCO	Grand Dink 125	125	4	10260309	-
HUPPER	Montecarlo 30 2T	50	2	10260219	-	KYMCO	Grand Dink 150	150	4	10260309	-
HUPPER	Montecarlo 30 4T	50	4	10260412	-	KYMCO	Grand Dink 250	250	4	10260323	-
ITALJET	Dragster *50 LC	50	2	10260231	10260218	KYMCO	Heroism	50	2	10260260	-
ITALJET	Dragster 125	125	2	10260307	-	KYMCO	K12	50	2	10260261	-
ITALJET	Dragster 180	180	2	10260307	-	KYMCO	K-XCT 300 i.e. euro 3	300	4	10260434	-
ITALJET	Formula *50	50	2	10260250	-	KYMCO	Like 125 4T	125	4	10260432	-
ITALJET	Formula *50 LC	50	2	10260250	-	KYMCO	Like 200 4T i.e.	200	4	10260432	-
ITALJET	Jet Set *50	50	2	10260254	10260254	KYMCO	Movie 125 4T	125	4	10260317	-
ITALJET	Jet-Set 125 (Leader Engine)	125	4	10260319	-	KYMCO	Movie 125 4T euro 3	125	4	10260432	-
ITALJET	Jet-Set 150 (Leader Engine)	150	4	10260319	-	KYMCO	Movie 150	150	4	10260317	-
ITALJET	Jupiter 125	125	4	10260308	-	KYMCO	People *50	50	2	10260261	-
ITALJET	Jupiter 150	150	4	10260308	-	KYMCO	People *50 4T euro 2	50	4	10260262	-
ITALJET	Jupiter 250	250	4	10260302	-	KYMCO	People 125	125	4	10260317	-
ITALJET	Millennium 100	100	2	10260315	-	KYMCO	People 150	150	4	10260432	-
ITALJET	Millennium 125	125	4	10260308	-	KYMCO	People 250	250	4	10260323	-
ITALJET	Millennium 150	150	4	10260308	-	KYMCO	People GTI 125 i.e.	125	4	10260429	-
ITALJET	Pista 2	50	2	10260231	10260218	KYMCO	People GTI 200 i.e.	200	4	10260434	-
ITALJET	Scoop	50	2	10260231	10260218	KYMCO	People GTI 300 i.e.	300	4	10260434	-
ITALJET	Torpedo *50 2T	50	2	10260250	-	KYMCO	People One 125 i.e. euro 3	125	4	10260432	-
ITALJET	Torpedo *50 2T New	50	2	10260254	10260254	KYMCO	People S *50 2T	50	2	10260261	-
ITALJET	Torpedo *50 4T	50	4	10260256	10260256	KYMCO	People S *50 4T	50	4	10260262	-
ITALJET	Torpedo 125	125	4	10260301	-	KYMCO	People S 125	125	4	10260432	-
ITALJET	Torpedo 125 (Leader Engine)	125	4	10260319	-	KYMCO	People S 200	200	4	10260432	-
ITALJET	Torpedo 150 (Leader Engine)	150	4	10260319	-	KYMCO	People S 250	250	4	10260323	-
ITALJET	Velocifero	50	2	10260250	-	KYMCO	People S 300	300	4	10260423	-
ITALJET	Yankee	50	2	10260231	10260218	KYMCO	Sento *50 4T	50	4	10260420	-
KAWASAKI	J 300 i.e. euro 3	300	4	10260434	-	KYMCO	Sniper *50 2T	50	2	10260260	-

BLOCK
 ASSEMBLY SYSTEM

MARCA	MODELLO	CC	TEMPI	OVERDRIVE	OVERDRIVE RULLI 019	MARCA	MODELLO	CC	TEMPI	OVERDRIVE	OVERDRIVE RULLI 019
BRAND	MODEL	CC	STROKE	OVERDRIVE	OVERDRIVE ROLLERS 019	BRAND	MODEL	CC	STROKE	OVERDRIVE	OVERDRIVE ROLLERS 019
KYMCO	Super 8 - *50 4T euro 2	50	4	10260420	-	MBK	Booster *50 NG euro 0-1	50	2	10260231	10260218
KYMCO	Super 8 - 125 4T euro 3	125	4	10260432	-	MBK	Booster *50 NG euro 2	50	2	10260231	10260218
KYMCO	Super 9 - *50 LC	50	2	10260261	-	MBK	Booster *50 Spirit euro 0-1	50	2	10260231	10260218
KYMCO	Super Dink 125 i.e. euro 3	125	4	10260429	-	MBK	Booster *50 X i.e. euro 2	50	4	10260418	-
KYMCO	Super Dink 200 i.e. euro 3	200	4	10260426	-	MBK	Booster 100 2T	100	2	10260315	-
KYMCO	Super Dink 300 i.e. euro 3	300	4	10260426	-	MBK	Cityliner 125	125	4	10260308	-
KYMCO	Super Dink 300 i.e. euro 3 > 2012	300	4	10260434	-	MBK	Doodo 125	125	4	10260308	-
KYMCO	Top Boy - Cobra *50	50	2	10260261	-	MBK	Doodo 150	150	4	10260308	-
KYMCO	Vitality *50	50	4	10260262	-	MBK	Evolis	50	2	10260231	10260218
KYMCO	Vivio 125	125	4	10260432	-	MBK	Fizz	50	2	10260231	10260218
KYMCO	Vivio 150	150	4	10260432	-	MBK	Flame 125	125	4	10260320	-
KYMCO	Xciting 250	250	4	10260323	-	MBK	Flipper	50	2	10260231	10260218
KYMCO	Xciting 300	300	4	10260423	-	MBK	Forte	50	2	10260231	10260218
KYMCO	Xciting 400 i.e. euro 3	400	4	10260443	-	MBK	Hot Champ	50	2	10260231	10260218
KYMCO	Xciting 500	500	4	10260428	-	MBK	Kilibre 300	300	4	10260302	-
KYMCO	Xciting 500 R i.e. euro 3	500	4	10260428	-	MBK	Mach G 50	50	2	10260231	10260218
KYMCO	Xciting R 300 i.e. euro 3	300	4	10260423	-	MBK	Mach G 50 LC	50	2	10260231	10260218
KYMCO	Yager 125 GT i.e. euro 3	125	4	10260309	-	MBK	Nitro *50	50	2	10260231	10260218
KYMCO	Yup 250	250	4	10260323	-	MBK	Nitro 100	100	2	10260315	-
LAVERDA	Phoenix 125	125	4	10260332	-	MBK	Ovetto *50	50	2	10260231	10260218
LAVERDA	Phoenix 150	150	4	10260332	-	MBK	Ovetto 100	100	2	10260315	-
LINHAI	Monarch 125	125	4	10260336	-	MBK	Rocket	50	2	10260231	10260218
LINHAI	Monarch 150	150	4	10260336	-	MBK	Rocket 50 euro 2	50	2	10260231	10260218
MALAGUTI	Blog 125 4T i.e.	125	4	10260430	-	MBK	Skycruiser 125 i.e.	125	4	10260308	-
MALAGUTI	Blog 160 4T i.e.	160	4	10260430	-	MBK	Skyliner 125	125	4	10260308	-
MALAGUTI	Centro *50 2T	50	2	10260231	10260218	MBK	Skyliner 150	150	4	10260308	-
MALAGUTI	Centro *50 4T	50	4	10260256	-	MBK	Skyliner 250	250	4	10260302	-
MALAGUTI	Centro 125 4T i.e.	125	4	10260410	-	MBK	Sorriso *50 2T 1996->	50	2	10260231	10260218
MALAGUTI	Ciak *50	50	2	10260231	10260218	MBK	Stunt *50 2T euro 0-1	50	2	10260231	10260218
MALAGUTI	Ciak 100	100	2	10260312	-	MBK	Stunt *50 2T euro 2	50	2	10260231	10260218
MALAGUTI	Ciak Master *50 4T euro 2	50	4	10260256	10260256	MBK	Target *50 2T	50	2	10260231	10260218
MALAGUTI	Ciak Master 125	125	4	10260432	-	MBK	Thunder 125	125	4	10260308	-
MALAGUTI	Ciak Master 150	150	4	10260432	-	MBK	Thunder 150	150	4	10260308	-
MALAGUTI	Ciak Master 200	200	4	10260432	-	MBK	X-Over 125 4T i.e.	125	4	10260409	-
MALAGUTI	Crosser CR1	50	2	10260250	-	PEUGEOT	Buxy - Buxy Rs *50 2T	50	2	10260280	-
MALAGUTI	Dvd *50 4T	50	4	10260412	-	PEUGEOT	Elyseo *50 2T	50	2	10260280	-
MALAGUTI	F10	50	2	10260231	10260218	PEUGEOT	Elyseo 100 2T	100	2	10260300	-
MALAGUTI	F10 Wap	50	2	10260219	-	PEUGEOT	Elyseo 100 KAT 2T	100	2	10260318	-
MALAGUTI	F12 Digit KAT 50 LC	50	2	10260231	10260218	PEUGEOT	Elyseo 125 4T	125	4	10260313	-
MALAGUTI	F12 Digit KAT 50 LC euro 2	50	2	10260231	10260218	PEUGEOT	Elyseo 150 4T	150	4	10260313	-
MALAGUTI	F12 Phanthom Max 250	250	4	10260329	-	PEUGEOT	Geopolis 125 i.e	125	4	10260415	-
MALAGUTI	F12 Phantom *50	50	2	10260231	10260218	PEUGEOT	Geopolis 250 i.e	250	4	10260329	-
MALAGUTI	F12 Phantom *50 LC	50	2	10260231	10260218	PEUGEOT	Geopolis 400	400	4	10260427	-
MALAGUTI	F12 Phantom 100	100	2	10260312	-	PEUGEOT	Geors 300 i.e.	300	4	10260329	-
MALAGUTI	F12 Phantom Max 125	125	4	10260308	-	PEUGEOT	Jet Force C-Tech *50 2T	50	2	10260280	-
MALAGUTI	F12 Phantom Max 200	200	4	10260329	-	PEUGEOT	Jet Force TSDI *50 2T	50	2	10260280	-
MALAGUTI	F12 R AIR euro 2	50	2	10260219	-	PEUGEOT	Looxor *50 2T	50	2	10260280	-
MALAGUTI	F12 R LC euro 2	50	2	10260231	10260218	PEUGEOT	Looxor TSDI *50 2T	50	2	10260280	-
MALAGUTI	F15 Firefox LC	50	2	10260231	10260218	PEUGEOT	Ludix *50 2T	50	2	10260280	-
MALAGUTI	F18 Warrior 125	125	4	10260309	-	PEUGEOT	Ludix Blaster *50 2T	50	2	10260280	-
MALAGUTI	F18 Warrior 150	150	4	10260309	-	PEUGEOT	LXR 125 4T	125	4	10260431	-
MALAGUTI	Madison 125	125	4	10260308	-	PEUGEOT	LXR 200 4T i.e.	200	4	10260309	-
MALAGUTI	Madison 150	150	4	10260308	-	PEUGEOT	Metal-X *50 2T	50	2	10260280	-
MALAGUTI	Madison 180	180	4	10260325	-	PEUGEOT	Satelis 125 4T	125	4	10260415	-
MALAGUTI	Madison 200	200	4	10260329	-	PEUGEOT	Satelis 125 Compressor 4T	125	4	10260416	-
MALAGUTI	Madison 250 (Motore Yamaha)	250	4	10260302	-	PEUGEOT	Satelis 250 4T	250	4	10260329	-
MALAGUTI	Madison 3 - 125 (Motore Piaggio)	125	4	10260319	-	PEUGEOT	Satelis 400 4T	400	4	10260427	-
MALAGUTI	Madison 3 - 250 (Motore Piaggio)	250	4	10260329	-	PEUGEOT	Satelis 500 4T	500	4	10260427	-
MALAGUTI	Madison K400	400	4	10260316	-	PEUGEOT	Speedake *50 2T	50	2	10260280	-
MALAGUTI	Madison RS 250 (Motore Quasar)	250	4	10260329	-	PEUGEOT	Speedfight *50 2T	50	2	10260280	-
MALAGUTI	Password 250	250	4	10260302	-	PEUGEOT	Speedfight *50 2T LC	50	2	10260280	-
MALAGUTI	Password CK 250	250	4	10260302	-	PEUGEOT	Speedfight 100	100	2	10260300	-
MALAGUTI	Spidermax GT 500 / 6 rulli	500	4	10260333	-	PEUGEOT	Speedfight 100 KAT 2T	100	2	10260318	-
MALAGUTI	Spidermax GT 500 / 8 rulli	500	4	10260402	-	PEUGEOT	Speedfight 2 *50 LC 2004->	50	2	10260280	-
MALAGUTI	Yesterday	50	2	10260231	10260218	PEUGEOT	Speedfight 3 *50 2T	50	2	10260280	-
MBK	Booster *50 euro 0-1	50	2	10260231	10260218	PEUGEOT	Speedfight 3 *50 4T	50	4	10260425	-
MBK	Booster *50 Naked euro 2	50	2	10260231	10260218	PEUGEOT	Squab *50 2T	50	2	10260280	-



MARCA	MODELLO	CC	TEMPI	OVERDRIVE	OVERDRIVE RULLI 019	MARCA	MODELLO	CC	TEMPI	OVERDRIVE	OVERDRIVE RULLI 019
BRAND	MODEL	CC	STROKE	OVERDRIVE	OVERDRIVE ROLLERS 019	BRAND	MODEL	CC	STROKE	OVERDRIVE	OVERDRIVE ROLLERS 019
PEUGEOT	SV 250 4T	250	4	10260303	-	PIAGGIO	MP3 YouUrban 300 4T 4V i.e. 2011->	300	4	10260329	-
PEUGEOT	Sv Geo *50 2T	50	2	10260245	-	PIAGGIO	NRG *50 LC	50	2	10260255	-
PEUGEOT	Trekker *50 2T	50	2	10260280	-	PIAGGIO	NRG Extreme	50	2	10260275	10260254
PEUGEOT	Trekker 100	100	2	10260300	-	PIAGGIO	NRG Extreme LC	50	2	10260254	10260254
PEUGEOT	Trekker 100 KAT 2T	100	2	10260318	-	PIAGGIO	NRG Mc2 LC <-1997	50	2	10260255	-
PEUGEOT	Tweet *50 4T	50	4	10260425	-	PIAGGIO	NRG Mc2 LC 1998->	50	2	10260275	10260254
PEUGEOT	Tweet 125 4T	125	4	10260431	-	PIAGGIO	NRG Mc3 DD LC	50	2	10260254	10260254
PEUGEOT	V-Clic *50 4T	50	4	10260412	-	PIAGGIO	NRG Mc3 DT	50	2	10260254	10260254
PEUGEOT	Vivacity *50 KAT 2T	50	2	10260280	-	PIAGGIO	NRG Mc3 PureJet LC	50	2	10260254	10260254
PEUGEOT	Vivacity 100	100	2	10260300	-	PIAGGIO	NRG Power DD LC	50	2	10260254	10260254
PEUGEOT	Vivacity 100 KAT 2T	100	2	10260318	-	PIAGGIO	NRG Power DT LC	50	2	10260254	10260254
PEUGEOT	Vivacity Compact *50 2T	50	2	10260280	-	PIAGGIO	NRG Power PureJet	50	2	10260254	10260254
PEUGEOT	X-Fight *50 2T	50	2	10260280	-	PIAGGIO	NTT LC	50	2	10260255	-
PEUGEOT	X-Fight *50 2T LC	50	2	10260280	-	PIAGGIO	Quartz LC	50	2	10260255	-
PEUGEOT	X-Fight 100 2T	100	2	10260318	-	PIAGGIO	Sfera *50 Rst	50	2	10260255	-
PEUGEOT	X-Fight 2 *50 LC 2004->	50	2	10260280	-	PIAGGIO	Skipper 125 2T	125	2	10260307	-
PEUGEOT	Zenith *50 2T	50	2	10260280	-	PIAGGIO	Skipper 125 ST 4T (Leader Engine)	125	4	10260319	-
PIAGGIO	Beverly 125 4T	125	4	10260319	-	PIAGGIO	Skipper 150 2T	150	2	10260307	-
PIAGGIO	Beverly 125 4T i.e. 2010->	125	4	10260319	-	PIAGGIO	Skipper 150 ST 4T (Leader Engine)	150	4	10260319	-
PIAGGIO	Beverly 200 4T	200	4	10260329	-	PIAGGIO	Skipper LX 125	125	2	10260307	-
PIAGGIO	Beverly 250 4T	250	4	10260329	-	PIAGGIO	Skipper LXT 150	150	2	10260307	-
PIAGGIO	Beverly 250 4T i.e.	250	4	10260329	-	PIAGGIO	Super Hexagon GTX 125 4T	125	4	10260319	-
PIAGGIO	Beverly 300 4T i.e.	300	4	10260329	-	PIAGGIO	Super Hexagon GTX 180 4T	180	4	10260325	-
PIAGGIO	Beverly 300 4T i.e. 2010->	300	4	10260329	-	PIAGGIO	Super Hexagon GTX 250	250	4	10260305	-
PIAGGIO	Beverly 350 Sport Touring 4T i.e.	350	4	10260437	-	PIAGGIO	Typhoon *50 2T 2007->2010	50	2	10260254	10260254
PIAGGIO	Beverly 400 4T i.e.	400	4	10260427	-	PIAGGIO	Typhoon *50 2T euro 2 - 2011->	50	2	10260254	10260254
PIAGGIO	Beverly 500 4T i.e. / 6 rulli	500	4	10260333	-	PIAGGIO	Typhoon 125 4T euro 3 (Leader Engine)	125	4	10260319	-
PIAGGIO	Beverly 500 4T i.e. / 8 rulli	500	4	10260427	-	PIAGGIO	X10 350 i.e. euro 3	350	4	10260437	-
PIAGGIO	Beverly Cruiser 250 i.e.	250	4	10260329	-	PIAGGIO	X10 500 i.e. euro 3	500	4	10260427	-
PIAGGIO	Beverly Cruiser 500 i.e. / 8 rulli	500	4	10260427	-	PIAGGIO	X7 125 4T euro 3 (Leader Engine)	125	4	10260319	-
PIAGGIO	Carnaby 125 4T	125	4	10260319	-	PIAGGIO	X7 250 4T i.e. euro 3 (Quasar Engine)	250	4	10260329	-
PIAGGIO	Carnaby 200 4T	200	4	10260329	-	PIAGGIO	X8 125 4T euro 2-3 (Leader Engine)	125	4	10260319	-
PIAGGIO	Diesis *50 2T	50	2	10260254	10260254	PIAGGIO	X8 200 4T	200	4	10260329	-
PIAGGIO	Fly *50 2T	50	2	10260254	10260254	PIAGGIO	X8 250 4T euro 2	250	4	10260329	-
PIAGGIO	Fly *50 4T	50	4	10260256	10260256	PIAGGIO	X8 250 4T i.e. euro 3	250	4	10260329	-
PIAGGIO	Fly 125 3V i.e. euro 3 > 2012	125	4	10260436	-	PIAGGIO	X8 400 4T i.e. euro 3	400	4	10260402	-
PIAGGIO	Fly 125 4T	125	4	10260319	-	PIAGGIO	X9 125 4T	125	4	10260319	-
PIAGGIO	Fly 150 4T	150	4	10260319	-	PIAGGIO	X9 180 4T Amalfi	180	4	10260325	-
PIAGGIO	Free *50 2T	50	2	10260255	-	PIAGGIO	X9 200 4T	200	4	10260329	-
PIAGGIO	Free 100 4T	100	4	10260330	-	PIAGGIO	X9 250 4T	250	4	10260303	-
PIAGGIO	Hexagon 125 2T	125	2	10260307	-	PIAGGIO	X9 250 4T Evolution	250	4	10260329	-
PIAGGIO	Hexagon 150 2T	150	2	10260307	-	PIAGGIO	X9 500 Evolution - Street / 6 rulli	500	4	10260333	-
PIAGGIO	Hexagon 250 4T	250	4	10260305	-	PIAGGIO	X9 500 Evolution Street / 8 rulli	500	4	10260402	-
PIAGGIO	Hexagon LX 125 2T	125	2	10260307	-	PIAGGIO	XEvo 125 4T euro 3	125	4	10260319	-
PIAGGIO	Hexagon LX 4 125 4T	125	4	10260301	-	PIAGGIO	XEvo 250 4T i.e. euro 3	250	4	10260329	-
PIAGGIO	Hexagon LXT 180 2T	180	2	10260307	-	PIAGGIO	XEvo 400 4T i.e. euro 3	400	4	10260402	-
PIAGGIO	Liberty *50 2T	50	2	10260275	10260254	PIAGGIO	Zip *50 2T	50	2	10260275	-
PIAGGIO	Liberty *50 4T	50	4	10260256	10260256	PIAGGIO	Zip *50 2T / 2000	50	2	10260275	10260254
PIAGGIO	Liberty 100 4T	100	4	10260330	-	PIAGGIO	Zip *50 4T	50	4	10260256	10260256
PIAGGIO	Liberty 125 3V i.e.	125	4	10260444	-	PIAGGIO	Zip 100 4T	100	4	10260330	-
PIAGGIO	Liberty 125 4T euro 0-1 <-1999	125	4	10260301	-	PIAGGIO	Zip 125 4T (Leader Engine)	125	4	10260319	-
PIAGGIO	Liberty 125 4T euro 1-2 (Leader Engine)	125	4	10260319	-	PIAGGIO	Zip Fast Rider	50	2	10260255	-
PIAGGIO	Liberty 125 4T euro 3 (Leader Engine)	125	4	10260319	-	PIAGGIO	Zip SP LC ->2000	50	2	10260255	-
PIAGGIO	Liberty 150 3V i.e.	150	4	10260436	-	PIAGGIO	Zip SP LC 2001->	50	2	10260275	10260254
PIAGGIO	Liberty 150 4T (Leader Engine)	150	4	10260319	-	RIZZATO	Vamos	50	2	10260250	-
PIAGGIO	Liberty 150 4T euro 1-2 (Leader Engine)	150	4	10260319	-	SUZUKI	Address Ah 50 2T	50	2	10260250	-
PIAGGIO	Liberty 150 4T euro 3 (Leader Engine)	150	4	10260319	-	SUZUKI	Address V 100 2T	100	2	10260337	-
PIAGGIO	Liberty 200 4T (Leader Engine)	200	4	10260329	-	SUZUKI	AP *50 2T	50	2	10260250	-
PIAGGIO	Liberty S 50 4T	50	4	10260256	10260256	SUZUKI	Burgman 125 K7 i.e.	125	4	10260311	-
PIAGGIO	Liberty S 125 4T (Leader Engine)	125	4	10260319	-	SUZUKI	Burgman 400 4T i.e. K 7	400	4	10260414	-
PIAGGIO	Liberty S 200 4T (Leader Engine)	200	4	10260329	-	SUZUKI	Burgman 400 4T i.e. K 8	400	4	10260414	-
PIAGGIO	MP3 125 4T (Leader Engine)	125	4	10260319	-	SUZUKI	Burgman 400 4T i.e. K 9	400	4	10260414	-
PIAGGIO	MP3 250 4T i.e. (Quasar Engine)	250	4	10260329	-	SUZUKI	Burgman 400 4T i.e. K10	400	4	10260414	-
PIAGGIO	MP3 300 4T i.e. (Quasar Engine)	300	4	10260329	-	SUZUKI	Burgman AN 250 - 2001->	250	4	10260328	-
PIAGGIO	MP3 400 4T i.e. (Master Engine)	400	4	10260402	-	SUZUKI	Burgman AN 250 <-2000	250	4	10260310	-
PIAGGIO	MP3 500 4T i.e.	500	4	10260427	-	SUZUKI	Burgman AN 400 4T - K3-K6	400	4	10260316	-
PIAGGIO	MP3 YouUrban 125 4T 4V i.e. 2011->	125	4	10260319	-	SUZUKI	Burgman UH 125 4T	125	4	10260311	-



B>LOCK
ASSEMBLY SYSTEM

MARCA	MODELLO	CC	TEMPI	OVERDRIVE	OVERDRIVE RULLI 019
BRAND	MODEL	CC	STROKE	OVERDRIVE	OVERDRIVE ROLLERS 019
SUZUKI	Burgman UH 150 4T	150	4	10260311	-
SUZUKI	Epicuro 125 4t	125	4	10260311	-
SUZUKI	Epicuro 150 4T	150	4	10260311	-
SUZUKI	Estilete - UF 50 2T	50	2	10260252	-
SUZUKI	Katana *50 - 1999->	50	2	10260252	-
SUZUKI	Katana *50 <-1998)	50	2	10260252	-
SUZUKI	Katana *50 LC <-1998	50	2	10260252	-
SUZUKI	Katana *50 LC 1999->	50	2	10260252	-
SUZUKI	Sepia *50 2T	50	2	10260250	-
SUZUKI	Sepia *50 ZZ 2T	50	2	10260250	-
SUZUKI	Sixteen 125 4T euro 3	125	4	10260311	-
SUZUKI	Sixteen 150 4T euro 3	150	4	10260311	-
SUZUKI	Street Magic	50	2	10260258	-
SUZUKI	Zillion *50 2T	50	2	10260252	-
SYM	Citycom 300 4T	300	4	10260417	-
SYM	DD *50 2T	50	2	10260260	-
SYM	Euro MX 125 4T	125	4	10260338	-
SYM	Fiddle 2 - 125 4T	125	4	10260421	-
SYM	GTS 125 4T	125	4	10260431	-
SYM	GTS Evo i 300 i.e.	300	4	10260417	-
SYM	GTS i 250 i.e.	250	4	10260417	-
SYM	HD Evo i 125 i.e.	125	4	10260431	-
SYM	HD Evo i 200 i.e.	200	4	10260309	-
SYM	Jet Basix *50 2T	50	2	10260260	-
SYM	Jet Sportx-S / Sportx-R *50	50	2	10260260	-
SYM	Joymax Evo i 300 i.e.	300	4	10260417	-
SYM	Joymax i 250 i.e.	250	4	10260417	-
SYM	Joyride 150	150	4	10260332	-
SYM	Joyride i 200 i.e.	200	4	10260309	-
SYM	Simply *50 4T	50	4	10260420	-
SYM	Super Duke 150 4T	150	4	10260324	-
SYM	Symphony *50 4T	50	4	10260425	-
SYM	Symphony S 125 4T euro 3	125	4	10260431	-
TGB	X Motion 250 4T	250	4	10260417	-
WT MOTORS	Atene 152 4T	152	4	10260430	-
WT MOTORS	Bilbao *50 4T	50	4	10260412	-
WT MOTORS	Kayman WT 150 4T	150	4	10260336	-
WT MOTORS	Miami 250 4T	250	4	10260422	-
YAMAHA	Aerox *50 euro 0-1	50	2	10260231	10260218
YAMAHA	Aerox *50 euro 2	50	2	10260231	10260218
YAMAHA	Aerox 100 2T	100	2	10260315	-
YAMAHA	Axis *50 2T	50	2	10260231	10260218
YAMAHA	Breeze *50 2T	50	2	10260231	10260218
YAMAHA	BW'S *50 euro 0-1	50	2	10260231	10260218
YAMAHA	BW'S *50 NG euro 0-1	50	2	10260231	10260218
YAMAHA	BW'S *50 NG euro 2	50	2	10260231	10260218
YAMAHA	BW'S *50 Original / Naked 2T euro 2 > 2010	50	2	10260231	10260218
YAMAHA	BW'S 100 2T	100	2	10260315	-
YAMAHA	BW'S 125 i.e. 4T euro 3	125	4	10260409	-
YAMAHA	CRZ *50 2T	50	2	10260231	10260218

MARCA	MODELLO	CC	TEMPI	OVERDRIVE	OVERDRIVE RULLI 019
BRAND	MODEL	CC	STROKE	OVERDRIVE	OVERDRIVE ROLLERS 019
YAMAHA	Cygnus 125 4T	125	4	10260320	-
YAMAHA	Cygnus 125 X 4T	125	4	10260409	-
YAMAHA	Cygnus 125 X 4T i.e. euro 3	125	4	10260409	-
YAMAHA	Giggle *50 4T i.e.	50	4	10260418	-
YAMAHA	Jog *50	50	2	10260231	10260218
YAMAHA	Jog *50 ER	50	2	10260231	10260218
YAMAHA	Jog *50 R	50	2	10260231	-
YAMAHA	Jog *50 RR	50	2	10260231	10260218
YAMAHA	Jog *50 Z	50	2	10260231	10260218
YAMAHA	Majesty 125 4T	125	4	10260308	-
YAMAHA	Majesty 150 4T	150	4	10260308	-
YAMAHA	Majesty 180 4T	180	4	10260400	-
YAMAHA	Majesty 250 4T	250	4	10260302	-
YAMAHA	Majesty 250 4T - 5VG japan version	250	4	10260339	-
YAMAHA	Majesty 400 4T <-2008	400	4	10260407	-
YAMAHA	Majesty 400 4T 2009->	400	4	10260424	-
YAMAHA	Maxster 125 4T	125	4	10260308	-
YAMAHA	Maxster 150 4T	150	4	10260308	-
YAMAHA	Neo's *50 2T	50	2	10260231	10260218
YAMAHA	Neo's *50 4T i.e.	50	4	10260418	-
YAMAHA	Neo's 100 2T	100	2	10260315	-
YAMAHA	Slider *50 2T	50	2	10260231	10260218
YAMAHA	S-Max 125 4T i.e.	125	4	10260441	-
YAMAHA	S-Max 160 4T i.e.	160	4	10260441	-
YAMAHA	Spy *50 2T	50	2	10260231	10260218
YAMAHA	Teo's 125 4T	125	4	10260308	-
YAMAHA	Teo's 150 4T	150	4	10260308	-
YAMAHA	TMax 500 <-2003	500	4	10260406	-
YAMAHA	TMax 500 i.e. <-2007	500	4	10260405	-
YAMAHA	TMax 500 i.e. 2008->2011	500	4	10260405	-
YAMAHA	TMax 530 4T i.e. > 2012	530	4	10260438	-
YAMAHA	Versity XC 300 4T	300	4	10260302	-
YAMAHA	Vino *50 2T	50	2	10260231	10260218
YAMAHA	Vity 125 4T	125	4	10260409	-
YAMAHA	Vox *50 4T i.e.	50	4	10260418	-
YAMAHA	Why *50 2T	50	2	10260231	10260218
YAMAHA	X-City 125 4T i.e.	125	4	10260308	-
YAMAHA	X-City 250 4T i.e.	250	4	10260302	-
YAMAHA	Xenter 125 4T i.e.	125	4	10260441	-
YAMAHA	Xenter 150 4T i.e. euro 3	150	4	10260441	-
YAMAHA	X-Max 125 4T i.e. <-2008	125	4	10260308	-
YAMAHA	X-Max 125 4T i.e. 2009->2013	125	4	10260411	-
YAMAHA	X-Max 125 4T i.e. euro 3 > 2014	125	4	10260411	-
YAMAHA	X-Max 250 4T	250	4	10260302	-
YAMAHA	X-Max 250 4T i.e. <-2009	250	4	10260302	-
YAMAHA	X-Max 250 4T i.e. 2010->2013	250	4	10260302	-
YAMAHA	X-Max 250 4T i.e. euro 3 > 2014	250	4	10260302	-
YAMAHA	X-Max 400 4T i.e. euro 3	400	4	10260424	-
YAMAHA	Zest *50 2T	50	2	10260231	10260218
YAMAHA	Zuma *50 2T	50	2	10260231	10260218

Variatori OVERSLIDE Speed Variator OVERSLIDE

Frutto della raffinata tecnologia Pinasco, questi variatori permettono di incrementare l'escursione complessiva rispetto ai componenti di serie, migliorando notevolmente la funzionalità e le prestazioni degli scooter. Il kit è abbinato al cuscinetto assiale Spring Slider che elimina la dannosa torsione della molla durante l'escursione del variatore migliorando le prestazioni e la fluidità di marcia.

The fruit of Pinasco technology these variator extend the overall operating range compared to OEM components, resulting in substantial improvement to the functionality and performance of the scooter. The kit is combined with axial bearing Spring Slider that eliminates harmful torsion spring during the excursion variator improving performance and fluidity of running.



B-LOCK è l'esclusivo sistema di montaggio della bronzina di scorrimento mozzo variatore, principalmente sui variatori per maxi scooter, effettuato senza nessun tipo di deformazione della stessa. Con l'impiego di questa tecnologia, oltre ad avere un perfetto accoppiamento senza rischi di rottura o fuoriuscita, la bronzina mantiene le sue dimensioni iniziali, garantendo costanza di prestazioni a caldo e nell'uso intensivo, assicurando una durata nel tempo superiore anche a quella dei variatori originali.

B-LOCK is the unique assembly system of variator bush, mainly on variators for maxi scooter, performed without any deformation. Using this technology, besides having a perfect coupling without risk of breakage or leakage, the bush keeps its own dimension, ensuring constant performance in hot and intensive use, as well as a superior durability even to the original variators.

MARCA	MODELLO	CC	TEMPI	OVERDRIVE	OVERDRIVE RULLI Ø19
BRAND	MODEL	CC	STROKE	OVERDRIVE	OVERDRIVE ROLLERS Ø19
APRILIA	Amico *50	50	2	-	10261345
APRILIA	Area 51	50	2	-	10261345
APRILIA	Atlantic - Arrecife 125	125	4	10261319	-
APRILIA	Atlantic - Arrecife 250	250	4	10261329	-
APRILIA	Atlantic 200	200	4	10261329	-
APRILIA	Atlantic 500 / 6 rulli	500	4	10261333	-
APRILIA	Atlantic Sprint - Arrecife 250	250	4	10261329	-
APRILIA	Atlantic Sprint - Arrecife 400	400	4	10261402	-
APRILIA	Atlantic Sprint - Arrecife 500	500	4	10261402	-
APRILIA	Gulliver *50	50	2	-	10261345
APRILIA	Gulliver *50 LC	50	2	-	10261345
APRILIA	Habana 125	125	4	10261301	-
APRILIA	Leonardo 125	125	4	10261306	-
APRILIA	Leonardo 150	150	4	10261306	-
APRILIA	Leonardo 150 ST	150	4	10261306	-
APRILIA	Leonardo 250	250	4	10261302	-
APRILIA	Leonardo 300	300	4	10261302	-
APRILIA	Mojito *50 Custom	50	2	-	10261351
APRILIA	Mojito 125	125	4	10261301	-
APRILIA	Mojito 125 RY (Leader)	125	4	10261319	-

MARCA	MODELLO	CC	TEMPI	OVERDRIVE	OVERDRIVE RULLI Ø19
BRAND	MODEL	CC	STROKE	OVERDRIVE	OVERDRIVE ROLLERS Ø19
APRILIA	Rally *50	50	2	-	10261345
APRILIA	Rally *50 LC	50	2	-	10261345
APRILIA	Scarabeo *50 2T	50	2	-	10261345
APRILIA	Scarabeo *50 2T Street Carburatore	50	2	-	10261351
APRILIA	Scarabeo *50 4T	50	4	-	10261352
APRILIA	Scarabeo *50 4T Street	50	4	-	10261352
APRILIA	Scarabeo 100 2T	100	2	10261315	-
APRILIA	Scarabeo 100 4T	100	4	10261330	-
APRILIA	Scarabeo 125	125	4	10261306	-
APRILIA	Scarabeo 125	125	4	10261319	-
APRILIA	Scarabeo 150	150	4	10261306	-
APRILIA	Scarabeo 200	200	4	10261331	-
APRILIA	Scarabeo 250	250	4	10261329	-
APRILIA	Scarabeo 500 / 6 rulli	500	4	10261333	-
APRILIA	Scarabeo Light 125	125	4	10261319	-
APRILIA	Scarabeo Light 200	200	4	10261329	-
APRILIA	Scarabeo Light 250 i.e. (dal 2007)	250	4	10261329	-
APRILIA	Scarabeo Light 400 i.e.	400	4	10261402	-
APRILIA	Scarabeo Light 500 i.e.	500	4	10261402	-
APRILIA	Scarabeo Special 300 i.e.	300	4	10261329	-



MARCA	MODELLO	CC	TEMPI	OVERDRIVE	OVERDRIVE RULLI Ø19	MARCA	MODELLO	CC	TEMPI	OVERDRIVE	OVERDRIVE RULLI Ø19
BRAND	MODEL	CC	STROKE	OVERDRIVE	OVERDRIVE ROLLERS Ø19	BRAND	MODEL	CC	STROKE	OVERDRIVE	OVERDRIVE ROLLERS Ø19
APRILIA	Sonic *50	50	2	-	10261345	GARELLI	Gsp *50	50	2	-	10261345
APRILIA	Sonic *50 LC	50	2	-	10261345	GARELLI	Sr *50	50	2	-	10261345
APRILIA	Sportcity 125	125	4	10261319	-	GARELLI	Tiesse Four *50	50	4	10261412	-
APRILIA	Sportcity 200	200	4	10261329	-	GARELLI	Xo' 125 i.e.	125	4	10261430	-
APRILIA	Sportcity 250 i.e. euro 3	250	4	10261329	-	GARELLI	Xo' 150 i.e.	150	4	10261430	-
APRILIA	Sportcity Cube 300 i.e.	300	4	10261329	-	GILERA	DNA *50 LC	50	2	-	10261351
APRILIA	Sportcity One *50 4T	50	4	-	10261352	GILERA	DNA 125	125	4	10261319	-
APRILIA	Sportcity One 125 4t	125	4	10261319	-	GILERA	DNA 180	180	4	10261325	-
APRILIA	SR *50 <-1993	50	2	-	10261345	GILERA	Fuoco 500 i.e.	500	4	10261402	-
APRILIA	SR *50 1994->	50	2	-	10261345	GILERA	Ice *50 2T	50	2	-	10261351
APRILIA	SR *50 2004 / Piaggio Carburatore	50	2	-	10261351	GILERA	Nexus 125 euro 3	125	4	10261319	-
APRILIA	SR *50 DiTech GP1 / Piaggio Iniezione	50	2	-	10261351	GILERA	Nexus 125 i.e. euro 3	125	4	10261319	-
APRILIA	SR *50 Netscaper LC	50	2	-	10261345	GILERA	Nexus 250 i.e. euro 3	250	4	10261329	-
APRILIA	SR *50 R / Piaggio Carburatore	50	2	-	10261351	GILERA	Nexus 300 i.e.	300	4	10261329	-
APRILIA	SR *50 R Factory	50	2	-	10261351	GILERA	Nexus 500 / 6 rulli	500	4	10261333	-
APRILIA	SR *50 Racing LC	50	2	-	10261345	GILERA	Nexus 500 / 8 rulli	500	4	10261402	-
APRILIA	SR *50 Replica LC	50	2	-	10261345	GILERA	Runner *50 LC < 2005	50	2	-	10261351
APRILIA	SR *50 Stealth LC	50	2	-	10261345	GILERA	Runner *50 PureJet <-2005	50	2	-	10261351
APRILIA	SR *50 WWW	50	2	-	10261345	GILERA	Runner *50 PureJet 2006->	50	2	-	10261351
APRILIA	SR 125	125	2	10261307	-	GILERA	Runner *50 SP LC <-2005	50	2	-	10261351
APRILIA	SR 150	150	2	10261307	-	GILERA	Runner *50 SP LC Carburatore 2006->	50	2	-	10261351
APRILIA	SR Max 125 i.e.	125	4	10261319	-	GILERA	Runner FX 125	125	2	10261307	-
APRILIA	SR Max 300 i.e.	300	4	10261329	-	GILERA	Runner FXR 180	180	2	10261307	-
APRILIA	SR Motard 125	125	4	10261319	-	GILERA	Runner ST 125 4T	125	4	10261329	-
ATALA	Carosello *50	50	2	-	10261345	GILERA	Runner ST 200 4T	200	4	10261329	-
BAOTIAN	ECO BIKE 50	50	4	10261412	-	GILERA	Runner VX 125 <-2005	125	4	10261319	-
BAOTIAN	REBEL - ROCKY - TANCO 9/12 - 50	50	4	10261412	-	GILERA	Runner VX 125 2006->	125	4	10261319	-
BENELLI	491 Gt	50	2	-	10261345	GILERA	Runner VXR 180	180	4	10261325	-
BENELLI	491 Sport LC	50	2	-	10261345	GILERA	Runner VXR 200 - 2006->	200	4	10261329	-
BENELLI	Adiva 125	125	4	10261319	-	GILERA	Runner VXR 200 <-2005	200	4	10261329	-
BENELLI	Adiva 150	150	4	10261319	-	GILERA	Stalker	50	2	-	10261351
BENELLI	Adiva AD 250	250	4	10261329	-	GILERA	Typhoon *50 X	50	2	-	10261351
BENELLI	K2 *50	50	2	-	10261345	GILERA	Typhoon 125	125	2	10261307	-
BENELLI	K2 *50 LC	50	2	-	10261345	GILERA	Typhoon 125 X	125	2	10261307	-
BENELLI	K2 100	100	2	10261315	-	HONDA	@125	125	4	10261321	-
BENELLI	Naked *50	50	2	-	10261345	HONDA	@150	150	4	10261321	-
BENELLI	Pepe *50	50	2	-	10261345	HONDA	Bali 100	100	2	10261314	-
BENELLI	Velvet 125	125	4	10261308	-	HONDA	CN 250	250	4	10261305	-
BENELLI	Velvet 150	150	4	10261308	-	HONDA	Dylan 125	125	4	10261321	-
BENELLI	Velvet 250	250	4	10261302	-	HONDA	Dylan 150	150	4	10261321	-
BENELLI	Velvet 400	400	4	10261316	-	HONDA	Foresight 250	250	4	10261303	-
BENELLI	Velvet 400 Dusk	400	4	10261316	-	HONDA	Forza 250 - 2001->	250	4	10261322	-
BETA	Ark *50	50	2	-	10261345	HONDA	Forza 300 ABS i.e.	300	4	10261404	-
BETA	Ark *50 LC	50	2	-	10261345	HONDA	Forza X 250 <-2007	250	4	10261403	-
BETA	Chrono	50	2	-	10261345	HONDA	Jazz 250 - 2001->	250	4	10261322	-
BETA	Eikon *50 LC	50	2	-	10261345	HONDA	Pantheon 125	125	2	10261304	-
BETA	Eikon 125	125	4	10261309	-	HONDA	Pantheon 125 4T i.e.	125	4	10261321	-
BETA	Eikon 150	150	4	10261309	-	HONDA	Pantheon 150	150	2	10261304	-
BETA	Quadra	50	2	-	10261345	HONDA	Pantheon 150 4T i.e.	150	4	10261321	-
BETA	Tempo	50	2	-	10261345	HONDA	PCX 125 i.e.	125	4	10261433	-
BSV	Ax	50	2	-	10261345	HONDA	PCX 125 i.e. euro 3 < 2011	125	4	10261440	-
BSV	Gz	50	2	-	10261345	HONDA	PCX 125 i.e. euro 3 > 2012	125	4	10261440	-
DERBI	Boulevard 125	125	4	10261319	-	HONDA	PCX 150 i.e. euro 3	150	4	10261440	-
DERBI	Boulevard 150	150	4	10261319	-	HONDA	PS 125 i.e.	125	4	10261321	-
DERBI	Boulevard 200	200	4	10261329	-	HONDA	PS 150 i.e.	150	4	10261321	-
DERBI	Bullet *50	50	2	-	10261351	HONDA	Reflex 250 > 2001	250	4	10261322	-
DERBI	GP1 *50 LC	50	2	-	10261351	HONDA	SH 100	100	2	10261314	-
DERBI	GP1 *50 OPEN	50	2	-	10261351	HONDA	SH 125	125	4	10261321	-
DERBI	GP1 *50 REVOLUTION	50	2	-	10261351	HONDA	SH 125 i.e.	125	4	10261321	-
DERBI	GP1 125 LC	125	4	10261319	-	HONDA	SH 125 i.e. 2009->	125	4	10261321	-
DERBI	GP1 250 LC	250	4	10261329	-	HONDA	SH 125 Mode i.e. euro 3	125	4	10261440	-
DERBI	Rambla 125	125	4	10261319	-	HONDA	SH 150	150	4	10261321	-
DERBI	Rambla 250	250	4	10261329	-	HONDA	SH 150 i.e.	150	4	10261321	-
DERBI	Rambla 300	300	4	10261329	-	HONDA	SH 150 i.e. 2009->	150	4	10261321	-
FANTIC	Big Wheel *50 2T	50	2	-	10261345	HONDA	SH 300 i.e. <-2010	300	4	10261404	-
GARELLI	Flexi' *50 4T	50	4	10261412	-	HONDA	SH 300 i.e. 2011->	300	4	10261404	-



MARCA	MODELLO	CC	TEMPI	OVERDRIVE	OVERDRIVE RULLI 019
BRAND	MODEL	CC	STROKE	OVERDRIVE	OVERDRIVE ROLLERS 019
HONDA	SH-I 125 ABS i.e. 2013 euro 3	125	4	10261442	-
HONDA	SH-I 150 ABS i.e. 2013 euro 3	150	4	10261442	-
HONDA	S-Wing 125 euro 3	125	4	10261321	-
HONDA	S-Wing 150 euro 3	150	4	10261321	-
HONDA	SW-T 400 euro 3	400	4	10261413	-
HONDA	Vision 110 i.e.	110	4	10261435	-
HUPPER	Montecarlo 30 4T	50	4	10261412	-
ITALJET	Dragster *50 LC	50	2	-	10261345
ITALJET	Dragster 125	125	2	10261307	-
ITALJET	Dragster 180	180	2	10261307	-
ITALJET	Jet Set *50	50	2	-	10261351
ITALJET	Jet-Set 125 (Leader Engine)	125	4	10261319	-
ITALJET	Jet-Set 150 (Leader Engine)	150	4	10261319	-
ITALJET	Jupiter 125	125	4	10261308	-
ITALJET	Jupiter 150	150	4	10261308	-
ITALJET	Jupiter 250	250	4	10261302	-
ITALJET	Millennium 100	100	2	10261315	-
ITALJET	Millennium 125	125	4	10261308	-
ITALJET	Millennium 150	150	4	10261308	-
ITALJET	Pista 2	50	2	-	10261345
ITALJET	Scoop	50	2	-	10261345
ITALJET	Torpedo *50 2T New	50	2	-	10261351
ITALJET	Torpedo *50 4T	50	4	-	10261352
ITALJET	Torpedo 125	125	4	10261301	-
ITALJET	Torpedo 125 (Leader Engine)	125	4	10261319	-
ITALJET	Torpedo 150 (Leader Engine)	150	4	10261319	-
ITALJET	Yankee	50	2	-	10261345
KAWASAKI	J 300 i.e. euro 3	300	4	10261434	-
KEEWAY	Logik 125 euro 3	125	4	10261321	-
KEEWAY	Outlook 125 4T	125	4	10261321	-
KEEWAY	Outlook 150 4T	150	4	10261321	-
KEEWAY	Zahara 125 euro 3	125	4	10261432	-
KYMCO	Agility 125 euro 3	125	4	10261432	-
KYMCO	Agility 150 euro 3	150	4	10261432	-
KYMCO	Agility R10/12 - RS *50 2T	50	4	10261420	-
KYMCO	Agility R16 - RS *50 4T	50	4	10261420	-
KYMCO	Agility R16 125 euro 3	125	4	10261432	-
KYMCO	Agility R16 150 euro 3	150	4	10261432	-
KYMCO	Agility R16 i 200 euro 3	200	4	10261432	-
KYMCO	Agility RS 125 euro 3	125	4	10261432	-
KYMCO	B&W 125	125	4	10261309	-
KYMCO	B&W 150	150	4	10261309	-
KYMCO	B&W 250	250	4	10261323	-
KYMCO	Dink *50 4T	50	4	10261420	-
KYMCO	Dink 125	125	4	10261309	-
KYMCO	Dink 150	150	4	10261309	-
KYMCO	Dink 200	200	4	10261309	-
KYMCO	Dink DD 200 i.e.	200	4	10261309	-
KYMCO	Dink Street 125 i.e.	125	4	10261429	-
KYMCO	Dink Street 200 i.e.	200	4	10261426	-
KYMCO	Dink Street 300 i.e.	300	4	10261426	-
KYMCO	Dink Street 300 i.e. 2012->	300	4	10261434	-
KYMCO	Downtown 125 i.e.	125	4	10261429	-
KYMCO	Downtown 200 i.e.	200	4	10261426	-
KYMCO	Downtown 300 i.e.	300	4	10261426	-
KYMCO	Downtown 300 i.e. 2012->	300	4	10261434	-
KYMCO	Grand Dink 125	125	4	10261309	-
KYMCO	Grand Dink 150	150	4	10261309	-
KYMCO	Grand Dink 250	250	4	10261323	-
KYMCO	K-XCT 300 i.e. euro 3	300	4	10261434	-
KYMCO	Like 125 4T	125	4	10261432	-
KYMCO	Like 200 4T i.e.	200	4	10261432	-
KYMCO	Movie 125 4T	125	4	10261317	-
KYMCO	Movie 125 4T euro 3	125	4	10261432	-
KYMCO	Movie 150	150	4	10261317	-
KYMCO	People 125	125	4	10261317	-

MARCA	MODELLO	CC	TEMPI	OVERDRIVE	OVERDRIVE RULLI 019
BRAND	MODEL	CC	STROKE	OVERDRIVE	OVERDRIVE ROLLERS 019
KYMCO	People 150	150	4	10261432	-
KYMCO	People 250	250	4	10261323	-
KYMCO	People GTI 125 i.e.	125	4	10261429	-
KYMCO	People GTI 200 i.e.	200	4	10261434	-
KYMCO	People GTI 300 i.e.	300	4	10261434	-
KYMCO	People One 125 i.e. euro 3	125	4	10261432	-
KYMCO	People S 125	125	4	10261432	-
KYMCO	People S 200	200	4	10261432	-
KYMCO	People S 250	250	4	10261323	-
KYMCO	People S 300	300	4	10261423	-
KYMCO	Sento *50 4T	50	4	10261420	-
KYMCO	Super 8 - *50 4T euro 2	50	4	10261420	-
KYMCO	Super 8 - 125 4T euro 3	125	4	10261432	-
KYMCO	Super Dink 125 i.e. euro 3	125	4	10261429	-
KYMCO	Super Dink 200 i.e. euro 3	200	4	10261426	-
KYMCO	Super Dink 300 i.e. euro 3	300	4	10261426	-
KYMCO	Super Dink 300 i.e. euro 3 > 2012	300	4	10261434	-
KYMCO	Vivio 125	125	4	10261432	-
KYMCO	Vivio 150	150	4	10261432	-
KYMCO	Xciting 250	250	4	10261323	-
KYMCO	Xciting 300	300	4	10261423	-
KYMCO	Xciting 400 i.e. euro 3	400	4	10261443	-
KYMCO	Xciting 500	500	4	10261428	-
KYMCO	Xciting 500 R i.e. euro 3	500	4	10261428	-
KYMCO	Xciting R 300 i.e. euro 3	300	4	10261423	-
KYMCO	Yager 125 GT i.e. euro 3	125	4	10261309	-
KYMCO	Yup 250	250	4	10261323	-
LAVERDA	Phoenix 125	125	4	10261332	-
LAVERDA	Phoenix 150	150	4	10261332	-
LINHAI	Monarch 125	125	4	10261336	-
LINHAI	Monarch 150	150	4	10261336	-
MALAGUTI	Blog 125 4T i.e.	125	4	10261430	-
MALAGUTI	Blog 160 4T i.e.	160	4	10261430	-
MALAGUTI	Centro *50 2T	50	2	-	10261345
MALAGUTI	Centro 125 4T i.e.	125	4	10261410	-
MALAGUTI	Ciak *50	50	2	-	10261345
MALAGUTI	Ciak 100	100	2	10261312	-
MALAGUTI	Ciak Master *50 4T euro 2	50	4	-	10261352
MALAGUTI	Ciak Master 125	125	4	10261432	-
MALAGUTI	Ciak Master 150	150	4	10261432	-
MALAGUTI	Ciak Master 200	200	4	10261432	-
MALAGUTI	Dvd *50 4T	50	4	10261412	-
MALAGUTI	F10	50	2	-	10261345
MALAGUTI	F12 Digit KAT 50 LC	50	2	-	10261345
MALAGUTI	F12 Digit KAT 50 LC euro 2	50	2	-	10261345
MALAGUTI	F12 Phantom Max 250	250	4	10261329	-
MALAGUTI	F12 Phantom *50	50	2	-	10261345
MALAGUTI	F12 Phantom *50 LC	50	2	-	10261345
MALAGUTI	F12 Phantom 100	100	2	10261312	-
MALAGUTI	F12 Phantom Max 125	125	4	10261308	-
MALAGUTI	F12 Phantom Max 200	200	4	10261329	-
MALAGUTI	F12 R LC euro 2	50	2	-	10261345
MALAGUTI	F15 Firefox LC	50	2	-	10261345
MALAGUTI	F18 Warrior 125	125	4	10261309	-
MALAGUTI	F18 Warrior 150	150	4	10261309	-
MALAGUTI	Madison 125	125	4	10261308	-
MALAGUTI	Madison 150	150	4	10261308	-
MALAGUTI	Madison 180	180	4	10261325	-
MALAGUTI	Madison 200	200	4	10261329	-
MALAGUTI	Madison 250 (Motore Yamaha)	250	4	10261302	-
MALAGUTI	Madison 3 - 125 (Motore Piaggio)	125	4	10261319	-
MALAGUTI	Madison 3 - 250 (Motore Piaggio)	250	4	10261329	-
MALAGUTI	Madison K400	400	4	10261316	-
MALAGUTI	Madison RS 250 (Motore Quasar)	250	4	10261329	-
MALAGUTI	Password 250	250	4	10261302	-
MALAGUTI	Password CK 250	250	4	10261302	-

B>LOCK
 ASSEMBLY SYSTEM

SCOOTER

MARCA	MODELLO	CC	TEMPI	OVERDRIVE	OVERDRIVE RULLI 019	MARCA	MODELLO	CC	TEMPI	OVERDRIVE	OVERDRIVE RULLI 019
BRAND	MODEL	CC	STROKE	OVERDRIVE	OVERDRIVE ROLLERS 019	BRAND	MODEL	CC	STROKE	OVERDRIVE	OVERDRIVE ROLLERS 019
MALAGUTI	Spidermax GT 500 / 6 rulli	500	4	10261333	-	PEUGEOT	X-Fight 100 2T	100	2	10261318	-
MALAGUTI	Spidermax GT 500 / 8 rulli	500	4	10261402	-	PIAGGIO	Beverly 125 4T	125	4	10261319	-
MALAGUTI	Yesterday	50	2	-	10261345	PIAGGIO	Beverly 125 4T i.e. 2010->	125	4	10261319	-
MBK	Booster *50 euro 0-1	50	2	-	10261345	PIAGGIO	Beverly 200 4T	200	4	10261329	-
MBK	Booster *50 Naked euro 2	50	2	-	10261345	PIAGGIO	Beverly 250 4T	250	4	10261329	-
MBK	Booster *50 NG euro 0-1	50	2	-	10261345	PIAGGIO	Beverly 250 4T i.e.	250	4	10261329	-
MBK	Booster *50 NG euro 2	50	2	-	10261345	PIAGGIO	Beverly 300 4T i.e.	300	4	10261329	-
MBK	Booster *50 Spirit euro 0-1	50	2	-	10261345	PIAGGIO	Beverly 300 4T i.e. 2010->	300	4	10261329	-
MBK	Booster *50 X i.e. euro 2	50	4	10261418	-	PIAGGIO	Beverly 350 Sport Touring 4T i.e.	350	4	10261437	-
MBK	Booster 100 2T	100	2	10261315	-	PIAGGIO	Beverly 400 4T i.e.	400	4	10261427	-
MBK	Cityliner 125	125	4	10261308	-	PIAGGIO	Beverly 500 4T i.e. / 6 rulli	500	4	10261333	-
MBK	Doodo 125	125	4	10261308	-	PIAGGIO	Beverly 500 4T i.e. / 8 rulli	500	4	10261427	-
MBK	Doodo 150	150	4	10261308	-	PIAGGIO	Beverly Cruiser 250 i.e.	250	4	10261329	-
MBK	Evolis	50	2	-	10261345	PIAGGIO	Beverly Cruiser 500 i.e. / 8 rulli	500	4	10261427	-
MBK	Fizz	50	2	-	10261345	PIAGGIO	Carnaby 125 4T	125	4	10261319	-
MBK	Flame 125	125	4	10261320	-	PIAGGIO	Carnaby 200 4T	200	4	10261329	-
MBK	Flipper	50	2	-	10261345	PIAGGIO	Diesis *50 2T	50	2	-	10261351
MBK	Forte	50	2	-	10261345	PIAGGIO	Fly *50 2T	50	2	-	10261351
MBK	Hot Champ	50	2	-	10261345	PIAGGIO	Fly *50 4T	50	4	-	10261352
MBK	Kilibre 300	300	4	10261302	-	PIAGGIO	Fly 125 3V i.e. euro 3 > 2012	125	4	10261436	-
MBK	Mach G 50	50	2	-	10261345	PIAGGIO	Fly 125 4T	125	4	10261319	-
MBK	Mach G 50 LC	50	2	-	10261345	PIAGGIO	Fly 150 4T	150	4	10261319	-
MBK	Nitro *50	50	2	-	10261345	PIAGGIO	Free 100 4T	100	4	10261330	-
MBK	Nitro 100	100	2	10261315	-	PIAGGIO	Hexagon 125 2T	125	2	10261307	-
MBK	Ovetto *50	50	2	-	10261345	PIAGGIO	Hexagon 150 2T	150	2	10261307	-
MBK	Ovetto 100	100	2	10261315	-	PIAGGIO	Hexagon 250 4T	250	4	10261305	-
MBK	Rocket	50	2	-	10261345	PIAGGIO	Hexagon LX 125 2T	125	2	10261307	-
MBK	Rocket 50 euro 2	50	2	-	10261345	PIAGGIO	Hexagon LX 4 125 4T	125	4	10261301	-
MBK	Skycruiser 125 i.e.	125	4	10261308	-	PIAGGIO	Hexagon LXT 180 2T	180	2	10261307	-
MBK	Skyliner 125	125	4	10261308	-	PIAGGIO	Liberty *50 2T	50	2	-	10261351
MBK	Skyliner 150	150	4	10261308	-	PIAGGIO	Liberty *50 4T	50	4	-	10261352
MBK	Skyliner 250	250	4	10261302	-	PIAGGIO	Liberty 100 4T	100	4	10261330	-
MBK	Sorriso *50 2T 1996->	50	2	-	10261345	PIAGGIO	Liberty 125 3V i.e.	125	4	10261444	-
MBK	Stunt *50 2T euro 0-1	50	2	-	10261345	PIAGGIO	Liberty 125 4T euro 0-1 <-1999	125	4	10261301	-
MBK	Stunt *50 2T euro 2	50	2	-	10261345	PIAGGIO	Liberty 125 4T euro 1-2 (Leader Engine)	125	4	10261319	-
MBK	Target *50 2T	50	2	-	10261345	PIAGGIO	Liberty 125 4T euro 3 (Leader Engine)	125	4	10261319	-
MBK	Thunder 125	125	4	10261308	-	PIAGGIO	Liberty 150 3V i.e.	150	4	10261436	-
MBK	Thunder 150	150	4	10261308	-	PIAGGIO	Liberty 150 4T (Leader Engine)	150	4	10261319	-
MBK	X-Over 125 4T i.e.	125	4	10261409	-	PIAGGIO	Liberty 150 4T euro 1-2 (Leader Engine)	150	4	10261319	-
PEUGEOT	Elyseo 100 2T	100	2	10261300	-	PIAGGIO	Liberty 150 4T euro 3 (Leader Engine)	150	4	10261319	-
PEUGEOT	Elyseo 100 KAT 2T	100	2	10261318	-	PIAGGIO	Liberty 200 4T (Leader Engine)	200	4	10261329	-
PEUGEOT	Elyseo 125 4T	125	4	10261313	-	PIAGGIO	Liberty S 50 4T	50	4	-	10261352
PEUGEOT	Elyseo 150 4T	150	4	10261313	-	PIAGGIO	Liberty S 125 4T (Leader Engine)	125	4	10261319	-
PEUGEOT	Geopolis 125 i.e	125	4	10261415	-	PIAGGIO	Liberty S 200 4T (Leader Engine)	200	4	10261329	-
PEUGEOT	Geopolis 250 i.e	250	4	10261329	-	PIAGGIO	MP3 125 4T (Leader Engine)	125	4	10261319	-
PEUGEOT	Geopolis 400	400	4	10261427	-	PIAGGIO	MP3 250 4T i.e. (Quasar Engine)	250	4	10261329	-
PEUGEOT	Geors 300 i.e.	300	4	10261329	-	PIAGGIO	MP3 300 4T i.e. (Quasar Engine)	300	4	10261329	-
PEUGEOT	LXR 125 4T	125	4	10261431	-	PIAGGIO	MP3 400 4T i.e. (Master Engine)	400	4	10261402	-
PEUGEOT	LXR 200 4T i.e.	200	4	10261309	-	PIAGGIO	MP3 500 4T i.e.	500	4	10261427	-
PEUGEOT	Satelis 125 4T	125	4	10261415	-	PIAGGIO	MP3 YouUrban 125 4T 4V i.e. 2011->	125	4	10261319	-
PEUGEOT	Satelis 125 Compressor 4T	125	4	10261416	-	PIAGGIO	MP3 YouUrban 300 4T 4V i.e. 2011->	300	4	10261329	-
PEUGEOT	Satelis 250 4T	250	4	10261329	-	PIAGGIO	NRG Extreme	50	2	-	10261351
PEUGEOT	Satelis 400 4T	400	4	10261427	-	PIAGGIO	NRG Extreme LC	50	2	-	10261351
PEUGEOT	Satelis 500 4T	500	4	10261427	-	PIAGGIO	NRG Mc2 LC 1998->	50	2	-	10261351
PEUGEOT	Speedfight 100	100	2	10261300	-	PIAGGIO	NRG Mc3 DD LC	50	2	-	10261351
PEUGEOT	Speedfight 100 KAT 2T	100	2	10261318	-	PIAGGIO	NRG Mc3 DT	50	2	-	10261351
PEUGEOT	Speedfight 3 *50 4T	50	4	10261425	-	PIAGGIO	NRG Mc3 PureJet LC	50	2	-	10261351
PEUGEOT	SV 250 4T	250	4	10261303	-	PIAGGIO	NRG Power DD LC	50	2	-	10261351
PEUGEOT	Trekker 100	100	2	10261300	-	PIAGGIO	NRG Power DT LC	50	2	-	10261351
PEUGEOT	Trekker 100 KAT 2T	100	2	10261318	-	PIAGGIO	NRG Power PureJet	50	2	-	10261351
PEUGEOT	Tweet *50 4T	50	4	10261425	-	PIAGGIO	Skipper 125 2T	125	2	10261307	-
PEUGEOT	Tweet 125 4T	125	4	10261431	-	PIAGGIO	Skipper 125 ST 4T (Leader Engine)	125	4	10261319	-
PEUGEOT	V-Click *50 4T	50	4	10261412	-	PIAGGIO	Skipper 150 2T	150	2	10261307	-
PEUGEOT	Vivacity 100	100	2	10261300	-	PIAGGIO	Skipper 150 ST 4T (Leader Engine)	150	4	10261319	-
PEUGEOT	Vivacity 100 KAT 2T	100	2	10261318	-	PIAGGIO	Skipper LX 125	125	2	10261307	-

BLOCK
ASSEMBLY SYSTEM

MARCA	MODELLO	CC	TEMPI	OVERDRIVE	OVERDRIVE RULLI 019
BRAND	MODEL	CC	STROKE	OVERDRIVE	OVERDRIVE ROLLERS 019
PIAGGIO	Skipper LXT 150	150	2	10261307	-
PIAGGIO	Super Hexagon GTX 125 4T	125	4	10261319	-
PIAGGIO	Super Hexagon GTX 180 4T	180	4	10261325	-
PIAGGIO	Super Hexagon GTX 250	250	4	10261305	-
PIAGGIO	Typhoon *50 2T 2007->2010	50	2	-	10261351
PIAGGIO	Typhoon *50 2T euro 2 - 2011->	50	2	-	10261351
PIAGGIO	Typhoon 125 4T euro 3 (Leader Engine)	125	4	10261319	-
PIAGGIO	X10 350 i.e. euro 3	350	4	10261437	-
PIAGGIO	X10 500 i.e. euro 3	500	4	10261427	-
PIAGGIO	X7 125 4T euro 3 (Leader Engine)	125	4	10261319	-
PIAGGIO	X7 250 4T i.e. euro 3 (Quasar Engine)	250	4	10261329	-
PIAGGIO	X8 125 4T euro 2-3 (Leader Engine)	125	4	10261319	-
PIAGGIO	X8 200 4T	200	4	10261329	-
PIAGGIO	X8 250 4T euro 2	250	4	10261329	-
PIAGGIO	X8 250 4T i.e. euro 3	250	4	10261329	-
PIAGGIO	X8 400 4T i.e. euro 3	400	4	10261402	-
PIAGGIO	X9 125 4T	125	4	10261319	-
PIAGGIO	X9 180 4T Amalfi	180	4	10261325	-
PIAGGIO	X9 200 4T	200	4	10261329	-
PIAGGIO	X9 250 4T	250	4	10261303	-
PIAGGIO	X9 250 4T Evolution	250	4	10261329	-
PIAGGIO	X9 500 Evolution - Street / 6 rulli	500	4	10261333	-
PIAGGIO	X9 500 Evolution Street / 8 rulli	500	4	10261402	-
PIAGGIO	XEvo 125 4T euro 3	125	4	10261319	-
PIAGGIO	XEvo 250 4T i.e. euro 3	250	4	10261329	-
PIAGGIO	XEvo 400 4T i.e. euro 3	400	4	10261402	-
PIAGGIO	Zip *50 2T / 2000	50	2	-	10261351
PIAGGIO	Zip *50 4T	50	4	-	10261352
PIAGGIO	Zip 100 4T	100	4	10261330	-
PIAGGIO	Zip 125 4T (Leader Engine)	125	4	10261319	-
PIAGGIO	Zip SP LC 2001->	50	2	-	10261351
SUZUKI	Address V 100 2T	100	2	10261337	-
SUZUKI	Burgman 125 K7 i.e.	125	4	10261311	-
SUZUKI	Burgman 400 4T i.e. K 7	400	4	10261414	-
SUZUKI	Burgman 400 4T i.e. K 8	400	4	10261414	-
SUZUKI	Burgman 400 4T i.e. K 9	400	4	10261414	-
SUZUKI	Burgman 400 4T i.e. K10	400	4	10261414	-
SUZUKI	Burgman AN 250 - 2001->	250	4	10261328	-
SUZUKI	Burgman AN 250 <-2000	250	4	10261310	-
SUZUKI	Burgman AN 400 4T - K3-K6	400	4	10261316	-
SUZUKI	Burgman UH 125 4T	125	4	10261311	-
SUZUKI	Burgman UH 150 4T	150	4	10261311	-
SUZUKI	Epicuro 125 4t	125	4	10261311	-
SUZUKI	Epicuro 150 4T	150	4	10261311	-
SUZUKI	Sixteen 125 4T euro 3	125	4	10261311	-
SUZUKI	Sixteen 150 4T euro 3	150	4	10261311	-
SYM	Citycom 300 4T	300	4	10261417	-
SYM	Euro MX 125 4T	125	4	10261338	-
SYM	Fiddle 2 - 125 4T	125	4	10261421	-
SYM	GTS 125 4T	125	4	10261431	-
SYM	GTS Evo i 300 i.e.	300	4	10261417	-
SYM	GTS i 250 i.e.	250	4	10261417	-
SYM	HD Evo i 125 i.e.	125	4	10261431	-
SYM	HD Evo i 200 i.e.	200	4	10261309	-
SYM	Joymax Evo i 300 i.e.	300	4	10261417	-
SYM	Joymax i 250 i.e.	250	4	10261417	-
SYM	Joyride 150	150	4	10261332	-
SYM	Joyride i 200 i.e.	200	4	10261309	-
SYM	Simply *50 4T	50	4	10261420	-
SYM	Super Duke 150 4T	150	4	10261324	-
SYM	Symphony *50 4T	50	4	10261425	-
SYM	Symphony S 125 4T euro 3	125	4	10261431	-
TGB	X Motion 250 4T	250	4	10261417	-
WT MOTORS	Atene 152 4T	152	4	10261430	-
WT MOTORS	Bilbao *50 4T	50	4	10261412	-

MARCA	MODELLO	CC	TEMPI	OVERDRIVE	OVERDRIVE RULLI 019
BRAND	MODEL	CC	STROKE	OVERDRIVE	OVERDRIVE ROLLERS 019
WT MOTORS	Kayman WT 150 4T	150	4	10261336	-
WT MOTORS	Miami 250 4T	250	4	10261422	-
YAMAHA	Aerox *50 euro 0-1	50	2	-	10261345
YAMAHA	Aerox *50 euro 2	50	2	-	10261345
YAMAHA	Aerox 100 2T	100	2	10261315	-
YAMAHA	Axis *50 2T	50	2	-	10261345
YAMAHA	Breeze *50 2T	50	2	-	10261345
YAMAHA	BW'S *50 euro 0-1	50	2	-	10261345
YAMAHA	BW'S *50 NG euro 0-1	50	2	-	10261345
YAMAHA	BW'S *50 NG euro 2	50	2	-	10261345
YAMAHA	BW'S *50 Original / Naked 2T euro 2 > 2010	50	2	-	10261345
YAMAHA	BW'S 100 2T	100	2	10261315	-
YAMAHA	BW'S 125 i.e. 4T euro 3	125	4	10261409	-
YAMAHA	CRZ *50 2T	50	2	-	10261345
YAMAHA	Cygnus 125 4T	125	4	10261320	-
YAMAHA	Cygnus 125 X 4T	125	4	10261409	-
YAMAHA	Cygnus 125 X 4T i.e. euro 3	125	4	10261409	-
YAMAHA	Giggle *50 4T i.e.	50	4	10261418	-
YAMAHA	Jog *50	50	2	-	10261345
YAMAHA	Jog *50 ER	50	2	-	10261345
YAMAHA	Jog *50 RR	50	2	-	10261345
YAMAHA	Jog *50 Z	50	2	-	10261345
YAMAHA	Majesty 125 4T	125	4	10261308	-
YAMAHA	Majesty 150 4T	150	4	10261308	-
YAMAHA	Majesty 180 4T	180	4	10261400	-
YAMAHA	Majesty 250 4T	250	4	10261302	-
YAMAHA	Majesty 250 4T - 5VG japan version	250	4	10261339	-
YAMAHA	Majesty 400 4T <-2008	400	4	10261407	-
YAMAHA	Majesty 400 4T 2009->	400	4	10261424	-
YAMAHA	Maxster 125 4T	125	4	10261308	-
YAMAHA	Maxster 150 4T	150	4	10261308	-
YAMAHA	Neo's *50 2T	50	2	-	10261345
YAMAHA	Neo's *50 4T i.e.	50	4	10261418	-
YAMAHA	Neo's 100 2T	100	2	10261315	-
YAMAHA	Slider *50 2T	50	2	-	10261345
YAMAHA	S-Max 125 4T i.e.	125	4	10261441	-
YAMAHA	S-Max 160 4T i.e.	160	4	10261441	-
YAMAHA	Spy *50 2T	50	2	-	10261345
YAMAHA	Teo's 125 4T	125	4	10261308	-
YAMAHA	Teo's 150 4T	150	4	10261308	-
YAMAHA	TMax 500 <-2003	500	4	10261406	-
YAMAHA	TMax 500 i.e. <-2007	500	4	10261405	-
YAMAHA	TMax 500 i.e. 2008->2011	500	4	10261405	-
YAMAHA	TMax 530 4T i.e. > 2012	530	4	10261438	-
YAMAHA	Versity XC 300 4T	300	4	10261302	-
YAMAHA	Vino *50 2T	50	2	-	10261345
YAMAHA	Vity 125 4T	125	4	10261409	-
YAMAHA	Vox *50 4T i.e.	50	4	10261418	-
YAMAHA	Why *50 2T	50	2	-	10261345
YAMAHA	X-City 125 4T i.e.	125	4	10261308	-
YAMAHA	X-City 250 4T i.e.	250	4	10261302	-
YAMAHA	Xenter 125 4T i.e.	125	4	10261441	-
YAMAHA	Xenter 150 4T i.e. euro 3	150	4	10261441	-
YAMAHA	X-Max 125 4T i.e. <-2008	125	4	10261308	-
YAMAHA	X-Max 125 4T i.e. 2009->2013	125	4	10261411	-
YAMAHA	X-Max 125 4T i.e. euro 3 > 2014	125	4	10261411	-
YAMAHA	X-Max 250 4T	250	4	10261302	-
YAMAHA	X-Max 250 4T i.e. <-2009	250	4	10261302	-
YAMAHA	X-Max 250 4T i.e. 2010->2013	250	4	10261302	-
YAMAHA	X-Max 250 4T i.e. euro 3 > 2014	250	4	10261302	-
YAMAHA	X-Max 400 4T i.e. euro 3	400	4	10261424	-
YAMAHA	Zest *50 2T	50	2	-	10261345
YAMAHA	Zurna *50 2T	50	2	-	10261345

Rulli Variatore Variator Rollers

Masse centrifughe realizzate in diversi diametri e pesi per una perfetta messa a punto della trasmissione automatica: grazie al particolare polimero impiegato nella loro costruzione sono estremamente resistenti al calore ed all'usura.

These weight sets are made in various diameters and weights to optimize performance from the automatic transmission. Thanks to the use of a special polymer they are highly resistant to heat and wear.

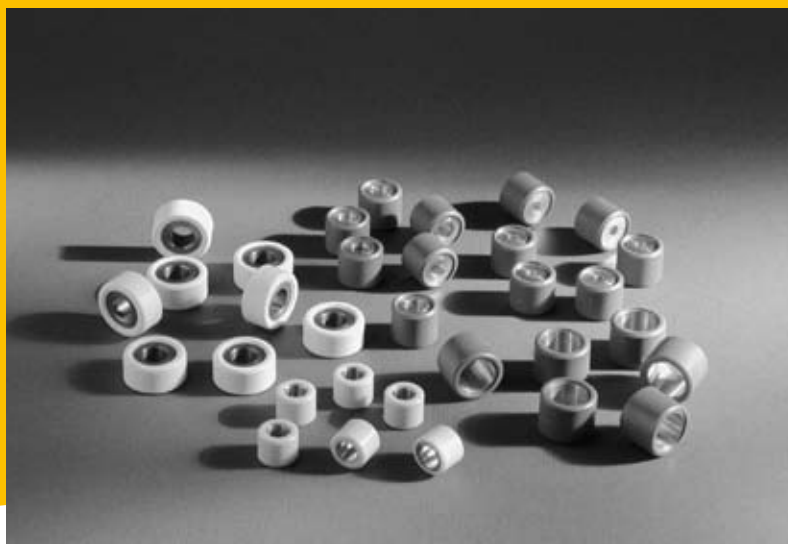

Ø 15 x 12 (6 PEZZI)

PESO Gr. WEIGHT Gr.	CODICE ITEM
3,5	10312414
4,0	10312331
4,5	10312332
5,0	10312307
5,6	10312333
6,0	10312308
6,5	10312334
7,0	10312335
7,5	10312336
8,0	10312337
8,5	10312363

Ø 16 x 13 (6 PEZZI)

PESO Gr. WEIGHT Gr.	CODICE ITEM
3,0	10312415
3,5	10312395
4,0	10312396
4,5	10312397
5,0	10312364
5,5	10312365
6,0	10312366
6,5	10312367
7,0	10312368
7,5	10312369
8,0	10312370
8,5	10312303
9,0	10312371
9,5	10312311
10,0	10312372
11,0	10312304

Ø 17 x 12 (6 PEZZI)

PESO Gr. WEIGHT Gr.	CODICE ITEM
5,0	10312306
5,5	10312373
6,0	10312374
6,5	10312341
7,0	10312375
7,5	10312316

Ø 18 x 14 (6 PEZZI)

PESO Gr. WEIGHT Gr.	CODICE ITEM
9,5	10312319
11,0	10312302
13,0	10312317
15,0	10312318

Ø 19 x 14 (6 PEZZI)

PESO Gr. WEIGHT Gr.	CODICE ITEM
8,8	10312328
12,0	10312327

Ø 19 x 15,5 (6 PEZZI)

PESO Gr. WEIGHT Gr.	CODICE ITEM
3,5	10312380
4,0	10312381
4,6	10312382
5,2	10312383
5,8	10312384
6,4	10312385
7,0	10312386
7,6	10312387
8,0	10312422
8,5	10312388

Ø 19 x 17 (6 PEZZI)

PESO Gr. WEIGHT Gr.	CODICE ITEM
7,5	10312423
8,5	10312424
10,5	10312309
11,5	10312300
12,5	10312301
13,5	10312310
15,5	10312323

Ø 20 x 18 (6 PEZZI)

PESO Gr. WEIGHT Gr.	CODICE ITEM
8,0	10312390
9,0	10312361
10,0	10312362
11,0	10312346
12,0	10312324
13,0	10312351
14,0	10312347

Ø 20 x 12 (8 PEZZI)

PESO Gr. WEIGHT Gr.	CODICE ITEM
8,0	10312391
9,0	10312376
10,0	10312377
11,0	10312338
12,0	10312345
13,0	10312350
14,0	10312313

Ø 20 x 15 (6 PEZZI)

PESO Gr. WEIGHT Gr.	CODICE ITEM
11,5	10312407
12,5	10312312
13,5	10312330
14,5	10312320
15,5	10312425

Ø 20 x 17 (6 PEZZI)

PESO Gr. WEIGHT Gr.	CODICE ITEM
8,5	10312342
9,0	10312343
9,5	10312326
10,5	10312352
11,0	10312379
11,5	10312353
12,5	10312354
13,5	10312355
14,5	10312344
15,5	10312329

Ø 20,9 x 17 (6 PEZZI)

PESO Gr. WEIGHT Gr.	CODICE ITEM
9,0	10312426
10,0	10312427
11,0	10312428

Ø 23 x 18 (6 PEZZI)

PESO Gr. WEIGHT Gr.	CODICE ITEM
10,0	10312356
11,0	10312357
12,0	10312358
13,0	10312359
14,0	10312339
15,0	10312321
16,0	10312322
17,0	10312360
18,0	10312340
20,0	10312378
21,0	10312394
23,0	10312315

Ø 24 x 18 (6 PEZZI)

PESO Gr. WEIGHT Gr.	CODICE ITEM
23,0	10312305
31,0	10312325

Ø 25 x 14,9 (8 PEZZI)

PESO Gr. WEIGHT Gr.	CODICE ITEM
10,0	10312420
11,0	10312421
12,0	10312408
13,0	10312416
14,0	10312409
15,0	10312410
16,0	10312398
18,0	10312399
20,0	10312400

Ø 25 x 17 (8 PEZZI)

PESO Gr. WEIGHT Gr.	CODICE ITEM
15,0	10312411
16,0	10312412
17,0	10312413

Ø 25 x 22,2 (6 PEZZI)

PESO Gr. WEIGHT Gr.	CODICE ITEM
20,0	10312401
22,0	10312402
24,0	10312403
26,0	10312404
28,0	10312405
30,0	10312406

Ø 26 x 13 (8 PEZZI)

PESO Gr. WEIGHT Gr.	CODICE ITEM
14,0	10312419
15,0	10312392
16,0	10312348
18,0	10312429
21,0	10312349

Ø 28 x 19,9 (8 PEZZI)

PESO Gr. WEIGHT Gr.	CODICE ITEM
18,0	10312418
21,0	10312417

Cinghie di Trasmissione Transmission Belts

Cinghie di trasmissione realizzate con miscela di gomma e inserti di kevlar nel tessuto radiale che assicurano un grip ottimale sulla puleggia e eccellenti doti di affidabilità in qualsiasi tipo di impiego.

Transmission belts made with a mix of rubber and Kevlar inserts in which provide an optimal grip on the pulley and excellent skills in reliability and any type of use.

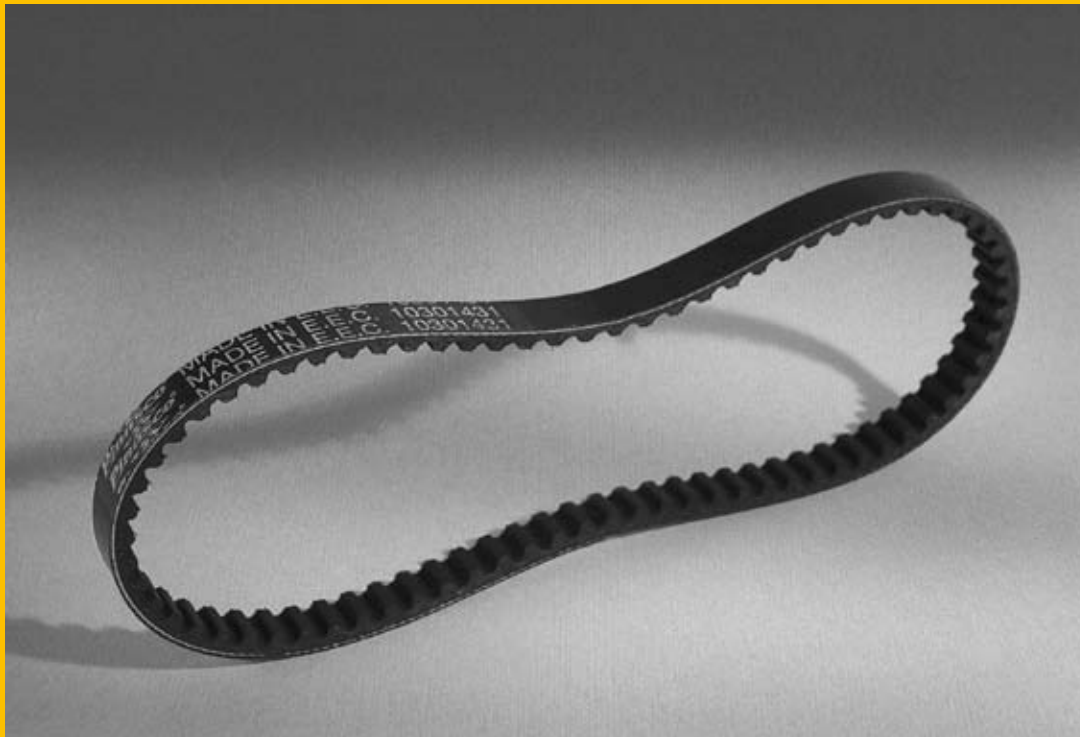

MARCA	MODELLO	CC	TEMPI	CODICE
BRAND	MODEL	CC	STROKE	ITEM
APRILIA	Amico *50	50	2	10301406
APRILIA	Area 51	50	2	10301406
APRILIA	Atlantic - Arrecife 125	125	4	10301433
APRILIA	Atlantic 200	200	4	10301436
APRILIA	Gulliver *50	50	2	10301406
APRILIA	Gulliver *50 LC	50	2	10301406
APRILIA	Habana *50	50	2	10301431
APRILIA	Leonardo 125	125	4	10301423
APRILIA	Leonardo 150	150	4	10301423
APRILIA	Leonardo 150 ST	150	4	10301423
APRILIA	Leonardo 250	250	4	10301424
APRILIA	Leonardo 300	300	4	10301424
APRILIA	Mojito *50	50	2	10301431
APRILIA	Mojito *50 Custom	50	2	10301419
APRILIA	Mojito 125 RY (Leader)	125	4	10301433
APRILIA	Rally *50	50	2	10301406
APRILIA	Rally *50 LC	50	2	10301406
APRILIA	Scarabeo *50 2T	50	2	10301406
APRILIA	Scarabeo *50 2T Street Carburatore	50	2	10301425
APRILIA	Scarabeo *50 4T	50	4	10301419
APRILIA	Scarabeo *50 4T Street	50	4	10301419
APRILIA	Scarabeo *50 DiTech / Aprilia	50	2	10301431
APRILIA	Scarabeo 125	125	4	10301423
APRILIA	Scarabeo 150	150	4	10301423
APRILIA	Scarabeo 200	200	4	10301423
APRILIA	Sonic *50	50	2	10301407
APRILIA	Sonic *50 LC	50	2	10301407
APRILIA	Sportcity 200	200	4	10301436
APRILIA	Sportcity One *50 4T	50	4	10301439
APRILIA	Sportcity One 125 4t	125	4	10301433
APRILIA	SR *50 <-1993	50	2	10301406
APRILIA	SR *50 1994->	50	2	10301406
APRILIA	SR *50 2004 / Piaggio Carburatore	50	2	10301419
APRILIA	SR *50 DiTech / Aprilia	50	2	10301431
APRILIA	SR *50 DiTech GP1 / Piaggio Iniezione	50	2	10301419

MARCA	MODELLO	CC	TEMPI	CODICE
BRAND	MODEL	CC	STROKE	ITEM
APRILIA	SR *50 Netscaper LC	50	2	10301406
APRILIA	SR *50 R / Piaggio Carburatore	50	2	10301419
APRILIA	SR *50 R Factory	50	2	10301419
APRILIA	SR *50 Racing LC	50	2	10301406
APRILIA	SR *50 Replica LC	50	2	10301406
APRILIA	SR *50 Replica LC 2000 / Aprilia	50	2	10301431
APRILIA	SR *50 Stealth LC	50	2	10301406
APRILIA	SR *50 WWW	50	2	10301406
APRILIA	SR 125	125	2	10301418
APRILIA	SR 150	150	2	10301418
ATALA	Carosello *50	50	2	10301406
ATALA	Hacker *50	50	2	10301409
ATALA	Hacker *50 LC	50	2	10301409
BENELLI	491 Gt	50	2	10301406
BENELLI	491 Sport LC	50	2	10301406
BENELLI	Adiva 125	125	4	10301433
BENELLI	Adiva 150	150	4	10301433
BENELLI	K2 *50	50	2	10301406
BENELLI	K2 *50 LC	50	2	10301406
BENELLI	Naked *50	50	2	10301406
BENELLI	Pepe *50	50	2	10301406
BENELLI	Pepe LX *50 euro 2	50	2	10301401
BENELLI	QuattroNove X *50 euro 2	50	2	10301401
BENELLI	Velvet 125	125	4	10301429
BENELLI	Velvet 150	150	4	10301429
BENELLI	Velvet 250	250	4	10301424
BETA	Ark *50	50	2	10301406
BETA	Ark *50 LC	50	2	10301406
BETA	Chrono	50	2	10301406
BETA	Eikon *50 LC	50	2	10301406
BETA	Eikon 125	125	4	10301423
BETA	Eikon 150	150	4	10301423
BETA	Quadra	50	2	10301406
BETA	Tempo	50	2	10301406
CAGIVA	Progress	50	2	10301432

MARCA	MODELLO	CC	TEMPI	CODICE	MARCA	MODELLO	CC	TEMPI	CODICE
BRAND	MODEL	CC	STROKE	ITEM	BRAND	MODEL	CC	STROKE	ITEM
CPI	Aragon GP - Hussar - Oliver - Popcorn 2003 >	50	2	10301401	ITALJET	Jet-Set 125 (Leader Engine)	125	4	10301433
CPI	Aragon GP - Hussar - Oliver - Popcorn > 2003	50	2	10301401	ITALJET	Jet-Set 150 (Leader Engine)	150	4	10301433
DERBI	Atlantis *50	50	2	10301432	ITALJET	Jupiter 125	125	4	10301429
DERBI	Atlantis *50 LC	50	2	10301432	ITALJET	Jupiter 150	150	4	10301429
DERBI	Boulevard 125	125	4	10301433	ITALJET	Jupiter 250	250	4	10301424
DERBI	Boulevard 150	150	4	10301433	ITALJET	Millennium 125	125	4	10301429
DERBI	Bullet *50	50	2	10301419	ITALJET	Millennium 150	150	4	10301429
DERBI	GP1 *50 LC	50	2	10301419	ITALJET	Pista	50	2	10301417
DERBI	GP1 *50 OPEN	50	2	10301419	ITALJET	Pista 2	50	2	10301406
DERBI	GP1 *50 REVOLUTION	50	2	10301419	ITALJET	Scoop	50	2	10301406
DERBI	Hunter	50	2	10301432	ITALJET	Torpedo *50 2T	50	2	10301409
DERBI	Paddock *50	50	2	10301432	ITALJET	Torpedo *50 2T New	50	2	10301425
DERBI	Paddock *50 LC	50	2	10301432	ITALJET	Torpedo 125 (Leader Engine)	125	4	10301433
DERBI	Predator *50	50	2	10301432	ITALJET	Torpedo 150 (Leader Engine)	150	4	10301433
DERBI	Predator *50 LC	50	2	10301432	ITALJET	Velocifero	50	2	10301409
EXPLORER	Cracker *50 2003>	50	2	10301401	ITALJET	Yankee	50	2	10301406
FANTIC	Big Wheel *50 2T	50	2	10301406	KEEWAY	F-ACT	50	2	10301401
GARELLI	Gsp *50	50	2	10301401	KEEWAY	Goccia	50	2	10301401
GARELLI	Tiesse *50 R	50	2	10301401	KEEWAY	Hurricane	50	2	10301401
GILERA	DNA *50 LC	50	2	10301425	KEEWAY	Matrix	50	2	10301401
GILERA	DNA 125	125	4	10301433	KEEWAY	Pixel	50	2	10301401
GILERA	Easy Moving	50	2	10301414	KEEWAY	RY8	50	2	10301401
GILERA	Ice *50 2T	50	2	10301419	KYMCO	B&W 125	125	4	10301423
GILERA	Nexus 125 euro 3	125	4	10301433	KYMCO	B&W 150	150	4	10301423
GILERA	Runner *50 LC <-2005	50	2	10301419	KYMCO	Dink *50	50	2	10301430
GILERA	Runner *50 PureJet <-2005	50	2	10301419	KYMCO	Dink 125	125	4	10301423
GILERA	Runner *50 PureJet 2006->	50	2	10301419	KYMCO	Dink 150	150	4	10301423
GILERA	Runner *50 SP LC <-2005	50	2	10301419	KYMCO	Dink DD 200 i.e.	200	4	10301423
GILERA	Runner *50 SP LC Carburatore 2006->	50	2	10301419	KYMCO	Grand Dink 125	125	4	10301423
GILERA	Runner FX 125	125	2	10301418	KYMCO	Grand Dink 150	150	4	10301423
GILERA	Runner FXR 180	180	2	10301418	KYMCO	People *50	50	2	10301430
GILERA	Runner VX 125 <-2005	125	4	10301433	KYMCO	People *50 4T euro 2	50	4	10301438
GILERA	Runner VXR 180	180	4	10301436	KYMCO	People S *50 2T	50	2	10301430
GILERA	Runner VXR 200 - 2006->	200	4	10301436	KYMCO	Super 8 - *50 4T euro 2	50	4	10301438
GILERA	Runner VXR 200 <-2005	200	4	10301436	KYMCO	Top Boy - Cobra *50	50	2	10301430
GILERA	Stalker	50	2	10301419	KYMCO	Vitality *50	50	4	10301438
GILERA	Storm	50	2	10301401	LEM	Flash *50 2T	50	2	10301407
GILERA	Typhoon	50	2	10301401	LEM	Ghibli *50 2T	50	2	10301407
GILERA	Typhoon *50 X	50	2	10301419	LEM	Tornado *50 2T	50	2	10301407
GILERA	Typhoon 125	125	2	10301418	MALAGUTI	Centro *50 2T	50	2	10301406
GILERA	Typhoon 125 X	125	2	10301418	MALAGUTI	Centro 160 4T i.e.	160	4	10301427
HONDA	@125	125	4	10301427	MALAGUTI	Ciak *50	50	2	10301406
HONDA	@150	150	4	10301427	MALAGUTI	Ciak 100	100	2	10301417
HONDA	Baili *50	50	2	10301402	MALAGUTI	Ciak Master *50 4T euro 2	50	4	10301439
HONDA	CN 250	250	4	10301422	MALAGUTI	Crosser CR1	50	2	10301417
HONDA	Dylan 125	125	4	10301427	MALAGUTI	F10	50	2	10301407
HONDA	Dylan 150	150	4	10301427	MALAGUTI	F10 Wap	50	2	10301401
HONDA	Foresight 250	250	4	10301421	MALAGUTI	F12 Digit KAT 50 LC	50	2	10301406
HONDA	Forza 250 - 2001->	250	4	10301421	MALAGUTI	F12 Digit KAT 50 LC euro 2	50	2	10301406
HONDA	Pantheon 125	125	2	10301427	MALAGUTI	F12 Phantom *50	50	2	10301406
HONDA	Pantheon 125 4T i.e.	125	4	10301427	MALAGUTI	F12 Phantom *50 LC	50	2	10301406
HONDA	Pantheon 150	150	2	10301427	MALAGUTI	F12 Phantom 100	100	2	10301417
HONDA	Pantheon 150 4T i.e.	150	4	10301427	MALAGUTI	F12 Phantom Max 125	125	4	10301429
HONDA	PS 125 i.e.	125	4	10301427	MALAGUTI	F12 Phantom Max 200	200	4	10301436
HONDA	PS 150 i.e.	150	4	10301427	MALAGUTI	F12 R AIR euro 2	50	2	10301401
HONDA	SFX *50	50	2	10301402	MALAGUTI	F12 R LC euro 2	50	2	10301406
HONDA	SH *50 - 1996->	50	2	10301420	MALAGUTI	F15 Firefox LC	50	2	10301406
HONDA	SH *50 <-1995	50	2	10301413	MALAGUTI	F18 Warrior 125	125	4	10301423
HONDA	SH 125	125	4	10301427	MALAGUTI	F18 Warrior 150	150	4	10301423
HONDA	SH 125 i.e.	125	4	10301427	MALAGUTI	Madison 125	125	4	10301429
HONDA	SH 150	150	4	10301427	MALAGUTI	Madison 150	150	4	10301429
HONDA	SH 150 i.e.	150	4	10301427	MALAGUTI	Madison 180	180	4	10301436
HONDA	Shadow *50	50	2	10301402	MALAGUTI	Madison 200	200	4	10301436
HONDA	Sky *50	50	2	10301420	MALAGUTI	Madison 250 (Motore Yamaha)	250	4	10301424
HONDA	S-Wing 125 euro 3	125	4	10301427	MALAGUTI	Madison 3 - 125 (Motore Piaggio)	125	4	10301433
HONDA	S-Wing 150 euro 3	150	4	10301427	MALAGUTI	Yesterday	50	2	10301407
HONDA	Sxr	50	2	10301402	MBK	Booster *50 euro 0-1	50	2	10301406
HONDA	X8R X-S	50	2	10301420	MBK	Booster *50 Naked euro 2	50	2	10301406
HUPPER	Montecarlo 30 2T	50	2	10301401	MBK	Booster *50 NG euro 0-1	50	2	10301406
ITALJET	Dragster *50 LC	50	2	10301406	MBK	Booster *50 NG euro 2	50	2	10301406
ITALJET	Dragster 125	125	2	10301418	MBK	Booster *50 Spirit euro 0-1	50	2	10301406
ITALJET	Dragster 180	180	2	10301418	MBK	Doodo 125	125	4	10301429
ITALJET	Formula *50	50	2	10301417	MBK	Doodo 150	150	4	10301429
ITALJET	Formula *50 LC	50	2	10301417	MBK	Evolis	50	2	10301407
ITALJET	Jet Set *50	50	2	10301419	MBK	Fizz	50	2	10301407

MARCA	MODELLO	CC	TEMPI	CODICE
BRAND	MODEL	CC	STROKE	ITEM
MBK	Flipper	50	2	10301406
MBK	Forte	50	2	10301407
MBK	Hot Champ	50	2	10301407
MBK	Mach G 50	50	2	10301406
MBK	Mach G 50 LC	50	2	10301406
MBK	Nitro *50	50	2	10301406
MBK	Ovetto *50	50	2	10301406
MBK	Rocket	50	2	10301406
MBK	Rocket 50 euro 2	50	2	10301406
MBK	Skyliner 125	125	4	10301429
MBK	Skyliner 150	150	4	10301429
MBK	Skyliner 250	250	4	10301424
MBK	Sorriso *50 2T 1996->	50	2	10301407
MBK	Stunt *50 2T euro 0-1	50	2	10301406
MBK	Stunt *50 2T euro 2	50	2	10301406
MBK	Target *50 2T	50	2	10301407
MBK	Thunder 125	125	4	10301429
MBK	Thunder 150	150	4	10301429
P.G.O.	Big Max *50 2T	50	2	10301406
PEUGEOT	Buxy - Buxy Rs *50 2T	50	2	10301416
PEUGEOT	Elyseo *50 2T	50	2	10301416
PEUGEOT	Elyseo 100 2T	100	2	10301419
PEUGEOT	Elyseo 100 KAT 2T	100	2	10301419
PEUGEOT	Jet Force C-Tech *50 2T	50	2	10301416
PEUGEOT	Jet Force TSDI *50 2T	50	2	10301416
PEUGEOT	Ludix *50 2T	50	2	10301416
PEUGEOT	Ludix Blaster *50 2T	50	2	10301416
PEUGEOT	Metal-X *50 2T	50	2	10301416
PEUGEOT	Speedake *50 2T	50	2	10301416
PEUGEOT	Speedfight *50 2T	50	2	10301416
PEUGEOT	Speedfight *50 2T LC	50	2	10301416
PEUGEOT	Speedfight 100	100	2	10301419
PEUGEOT	Speedfight 100 KAT 2T	100	2	10301419
PEUGEOT	Speedfight 2 *50 LC 2004->	50	2	10301416
PEUGEOT	Squab *50 2T	50	2	10301416
PEUGEOT	SV 250 4T	250	4	10301421
PEUGEOT	Sv Geo *50 2T	50	2	10301402
PEUGEOT	Trekker *50 2T	50	2	10301416
PEUGEOT	Trekker 100	100	2	10301419
PEUGEOT	Trekker 100 KAT 2T	100	2	10301419
PEUGEOT	Vivacity *50 KAT 2T	50	2	10301416
PEUGEOT	Vivacity 100	100	2	10301419
PEUGEOT	Vivacity 100 KAT 2T	100	2	10301419
PEUGEOT	X-Fight *50 2T	50	2	10301416
PEUGEOT	X-Fight *50 2T LC	50	2	10301416
PEUGEOT	X-Fight 2 *50 LC 2004->	50	2	10301416
PEUGEOT	Zenith *50 2T	50	2	10301402
PIAGGIO	Beverly 200 4T	200	4	10301436
PIAGGIO	Carnaby 200 4T	200	4	10301436
PIAGGIO	Diesis *50 2T	50	2	10301419
PIAGGIO	Fly *50 2T	50	2	10301419
PIAGGIO	Fly 125 4T	125	4	10301433
PIAGGIO	Fly 150 4T	150	4	10301433
PIAGGIO	Free *50 2T	50	2	10301401
PIAGGIO	Hexagon 125 2T	125	2	10301418
PIAGGIO	Hexagon 150 2T	150	2	10301418
PIAGGIO	Hexagon 250 4T	250	4	10301422
PIAGGIO	Hexagon LX 125 2T	125	2	10301418
PIAGGIO	Hexagon LXT 180 2T	180	2	10301418
PIAGGIO	Liberty *50 2T	50	2	10301425
PIAGGIO	Liberty *50 4T	50	4	10301419
PIAGGIO	Liberty 125 4T euro 1-2 (Leader Engine)	125	4	10301433
PIAGGIO	Liberty 150 4T (Leader Engine)	150	4	10301433
PIAGGIO	Liberty 150 4T euro 1-2 (Leader Engine)	150	4	10301433
PIAGGIO	Liberty 200 4T (Leader Engine)	200	4	10301436
PIAGGIO	Liberty S 125 4T (Leader Engine)	125	4	10301433
PIAGGIO	Liberty S 200 4T (Leader Engine)	200	4	10301436
PIAGGIO	MP3 125 4T (Leader Engine)	125	4	10301433
PIAGGIO	NRG *50 LC	50	2	10301401
PIAGGIO	NRG Extreme	50	2	10301419
PIAGGIO	NRG Extreme LC	50	2	10301419
PIAGGIO	NRG Mc2 LC <-1997	50	2	10301401
PIAGGIO	NRG Mc2 LC 1998->	50	2	10301419
PIAGGIO	NRG Mc3 DD LC	50	2	10301419
PIAGGIO	NRG Mc3 DT	50	2	10301419

MARCA	MODELLO	CC	TEMPI	CODICE
BRAND	MODEL	CC	STROKE	ITEM
PIAGGIO	NRG Mc3 PureJet LC	50	2	10301419
PIAGGIO	NRG Power DD LC	50	2	10301419
PIAGGIO	NRG Power DT LC	50	2	10301419
PIAGGIO	NRG Power PureJet	50	2	10301419
PIAGGIO	NTT LC	50	2	10301401
PIAGGIO	Quartz LC	50	2	10301414
PIAGGIO	Sfera *50	50	2	10301410
PIAGGIO	Sfera *50 Rst	50	2	10301414
PIAGGIO	Sfera *75	75	2	10301410
PIAGGIO	Skipper 125 2T	125	2	10301418
PIAGGIO	Skipper 125 ST 4T (Leader Engine)	125	4	10301433
PIAGGIO	Skipper 150 2T	150	2	10301418
PIAGGIO	Skipper 150 ST 4T (Leader Engine)	150	4	10301433
PIAGGIO	Skipper LX 125	125	2	10301418
PIAGGIO	Skipper LXT 150	150	2	10301418
PIAGGIO	Super Hexagon GTX 125 4T	125	4	10301433
PIAGGIO	Super Hexagon GTX 180 4T	180	4	10301436
PIAGGIO	Super Hexagon GTX 250	250	4	10301422
PIAGGIO	Typhoon *50 2T 2007->2010	50	2	10301419
PIAGGIO	Typhoon *50 2T euro 2 - 2011->	50	2	10301425
PIAGGIO	X7 125 4T euro 3 (Leader Engine)	125	4	10301433
PIAGGIO	X8 125 4T euro 2-3 (Leader Engine)	125	4	10301433
PIAGGIO	X8 200 4T	200	4	10301436
PIAGGIO	X9 125 4T	125	4	10301433
PIAGGIO	X9 180 4T Amalfi	180	4	10301436
PIAGGIO	X9 200 4T	200	4	10301436
PIAGGIO	X9 250 4T	250	4	10301421
PIAGGIO	XEvo 125 4T euro 3	125	4	10301433
PIAGGIO	Zip *50 2T	50	2	10301410
PIAGGIO	Zip *50 2T / 2000	50	2	10301440
PIAGGIO	Zip 125 4T (Leader Engine)	125	4	10301433
PIAGGIO	Zip Fast Rider	50	2	10301414
PIAGGIO	Zip SP LC ->2000	50	2	10301414
PIAGGIO	Zip SP LC 2001->	50	2	10301440
RIZZATO	Vamos	50	2	10301409
SUZUKI	Address Ah 50 2T	50	2	10301409
SUZUKI	AP *50 2T	50	2	10301409
SUZUKI	Burgman 200 4T i.e. euro 3	200	4	10301428
SUZUKI	Burgman AN 400 4T - K3-K6	400	4	10301434
SUZUKI	Estilite - UF 50 2T	50	2	10301431
SUZUKI	Katana *50 <-1998	50	2	10301431
SUZUKI	Katana *50 LC <-1998	50	2	10301431
SUZUKI	Sepia *50 2T	50	2	10301409
SUZUKI	Sepia *50 ZZ 2T	50	2	10301409
SUZUKI	Zillion *50 2T	50	2	10301431
YAMAHA	Aerox *50 euro 0-1	50	2	10301406
YAMAHA	Aerox *50 euro 2	50	2	10301406
YAMAHA	Axis *50 2T	50	2	10301407
YAMAHA	Breeze *50 2T	50	2	10301407
YAMAHA	BW'S *50 euro 0-1	50	2	10301406
YAMAHA	BW'S *50 NG euro 0-1	50	2	10301406
YAMAHA	BW'S *50 NG euro 2	50	2	10301406
YAMAHA	BW'S *50 Original / Naked 2T euro 2 > 2010	50	2	10301406
YAMAHA	CRZ *50 2T	50	2	10301407
YAMAHA	Giggle *50 4T i.e.	50	4	10301407
YAMAHA	Jog *50	50	2	10301407
YAMAHA	Jog *50 ER	50	2	10301407
YAMAHA	Jog *50 R	50	2	10301406
YAMAHA	Jog *50 RR	50	2	10301406
YAMAHA	Jog *50 Z	50	2	10301407
YAMAHA	Majesty 125 4T	125	4	10301429
YAMAHA	Majesty 150 4T	150	4	10301429
YAMAHA	Majesty 180 4T	180	4	10301435
YAMAHA	Majesty 250 4T	250	4	10301424
YAMAHA	Maxster 125 4T	125	4	10301429
YAMAHA	Maxster 150 4T	150	4	10301429
YAMAHA	Neo's *50 2T	50	2	10301406
YAMAHA	Slider *50 2T	50	2	10301406
YAMAHA	Spy *50 2T	50	2	10301406
YAMAHA	Teo's 125 4T	125	4	10301429
YAMAHA	Teo's 150 4T	150	4	10301429
YAMAHA	Vino *50 2T	50	2	10301407
YAMAHA	Why *50 2T	50	2	10301406
YAMAHA	Zest *50 2T	50	2	10301407
YAMAHA	Zuma *50 2T	50	2	10301406

Frizione con Campana Clutch with Bell

Frizione completa alleggerita con molle rinforzate di varia durezza, aumenta notevolmente la ripresa garantendo riprese più scattanti, la frizione viene venduta con la sua campana specifica maggiorata da 110mm

Complete lightened clutch with reinforced springs of various strength. It increases the acceleration. The specific special bell of 110 mm is included in the kit



MARCA	MODELLO	CC	TEMPI	CODICE
BRAND	MODEL	CC	STROKE	ITEM
APRILIA	Amico *50	50	2	10090150
APRILIA	Area 51	50	2	10090150
APRILIA	Gulliver *50	50	2	10090150
APRILIA	Gulliver *50 LC	50	2	10090150
APRILIA	Rally *50	50	2	10090150
APRILIA	Rally *50 LC	50	2	10090150
APRILIA	Scarabeo *50 2T	50	2	10090150
APRILIA	Scarabeo 100 2T	100	2	10090150
APRILIA	Sonic *50	50	2	10090150
APRILIA	Sonic *50 LC	50	2	10090150
APRILIA	SR *50 <-1993	50	2	10090150
APRILIA	SR *50 1994->	50	2	10090150
APRILIA	SR *50 Netscaper LC	50	2	10090150
APRILIA	SR *50 Racing LC	50	2	10090150
APRILIA	SR *50 Replica LC	50	2	10090150
APRILIA	SR *50 Stealth LC	50	2	10090150
APRILIA	SR *50 WWW	50	2	10090150
ATALA	Carosello *50	50	2	10090150
BENELLI	491 Gt	50	2	10090150
BENELLI	491 Sport LC	50	2	10090150
BENELLI	K2 *50	50	2	10090150
BENELLI	K2 *50 LC	50	2	10090150
BENELLI	K2 100	100	2	10090150
BENELLI	Naked *50	50	2	10090150
BENELLI	Pepe *50	50	2	10090150
BETA	Ark *50	50	2	10090150
BETA	Ark *50 LC	50	2	10090150
BETA	Chrono	50	2	10090150
BETA	Eikon *50 LC	50	2	10090150
BETA	Quadra	50	2	10090150
BETA	Tempo	50	2	10090150
BSV	Ax	50	2	10090150
BSV	Gz	50	2	10090150
GARELLI	Sr *50	50	2	10090150
ITALJET	Dragster *50 LC	50	2	10090150
ITALJET	Pista 2	50	2	10090150
ITALJET	Scoop	50	2	10090150
ITALJET	Yankee	50	2	10090150
MALAGUTI	Centro *50 2T	50	2	10090150
MALAGUTI	Ciak *50	50	2	10090150
MALAGUTI	Ciak 100	100	2	10090150
MALAGUTI	F10	50	2	10090150
MALAGUTI	F12 Digit KAT 50 LC	50	2	10090150
MALAGUTI	F12 Digit KAT 50 LC euro 2	50	2	10090150
MALAGUTI	F12 Phantom *50	50	2	10090150
MALAGUTI	F12 Phantom *50 LC	50	2	10090150
MALAGUTI	F12 Phantom 100	100	2	10090150
MALAGUTI	F12 R LC euro 2	50	2	10090150
MALAGUTI	F15 Firefox LC	50	2	10090150

MARCA	MODELLO	CC	TEMPI	CODICE
BRAND	MODEL	CC	STROKE	ITEM
MALAGUTI	Yesterday	50	2	10090150
MBK	Booster *50 euro 0-1	50	2	10090150
MBK	Booster *50 Naked euro 2	50	2	10090150
MBK	Booster *50 NG euro 0-1	50	2	10090150
MBK	Booster *50 NG euro 2	50	2	10090150
MBK	Booster *50 Spirit euro 0-1	50	2	10090150
MBK	Booster 100 2T	100	2	10090150
MBK	Evolis	50	2	10090150
MBK	Fizz	50	2	10090150
MBK	Flipper	50	2	10090150
MBK	Forte	50	2	10090150
MBK	Hot Champ	50	2	10090150
MBK	Mach G 50	50	2	10090150
MBK	Mach G 50 LC	50	2	10090150
MBK	Nitro *50	50	2	10090150
MBK	Ovetto *50	50	2	10090150
MBK	Ovetto 100	100	2	10090150
MBK	Rocket	50	2	10090150
MBK	Rocket 50 euro 2	50	2	10090150
MBK	Sorriso *50 2T 1996->	50	2	10090150
MBK	Stunt *50 2T euro 0-1	50	2	10090150
MBK	Stunt *50 2T euro 2	50	2	10090150
MBK	Target *50 2T	50	2	10090150
P.G.O.	Big Max *50 2T	50	2	10090150
YAMAHA	Aerox *50 euro 0-1	50	2	10090150
YAMAHA	Aerox *50 euro 2	50	2	10090150
YAMAHA	Aerox 100 2T	100	2	10090150
YAMAHA	Axis *50 2T	50	2	10090150
YAMAHA	Breeze *50 2T	50	2	10090150
YAMAHA	BW'S *50 euro 0-1	50	2	10090150
YAMAHA	BW'S *50 NG euro 0-1	50	2	10090150
YAMAHA	BW'S *50 NG euro 2	50	2	10090150
YAMAHA	BW'S *50 Original / Naked 2T euro 2 > 2010	50	2	10090150
YAMAHA	BW'S 100 2T	100	2	10090150
YAMAHA	CRZ *50 2T	50	2	10090150
YAMAHA	Jog *50	50	2	10090150
YAMAHA	Jog *50 ER	50	2	10090150
YAMAHA	Jog *50 R	50	2	10090150
YAMAHA	Jog *50 RR	50	2	10090150
YAMAHA	Jog *50 Z	50	2	10090150
YAMAHA	Neo's *50 2T	50	2	10090150
YAMAHA	Neo's 100 2T	100	2	10090150
YAMAHA	Slider *50 2T	50	2	10090150
YAMAHA	Spy *50 2T	50	2	10090150
YAMAHA	Vino *50 2T	50	2	10090150
YAMAHA	Why *50 2T	50	2	10090150
YAMAHA	Zest *50 2T	50	2	10090150
YAMAHA	Zuma *50 2T	50	2	10090150

Frizione Pinasco Pinasco Clutch

Frizione completa alleggerita in fusione di alluminio, aumenta notevolmente la ripresa garantendo riprese più scattanti, il kit viene fornito con molle di diversa durezza per una regolazione ideale

Complete lightened clutch made of aluminium. It increases the acceleration. Some springs with different strength are included in the kit.

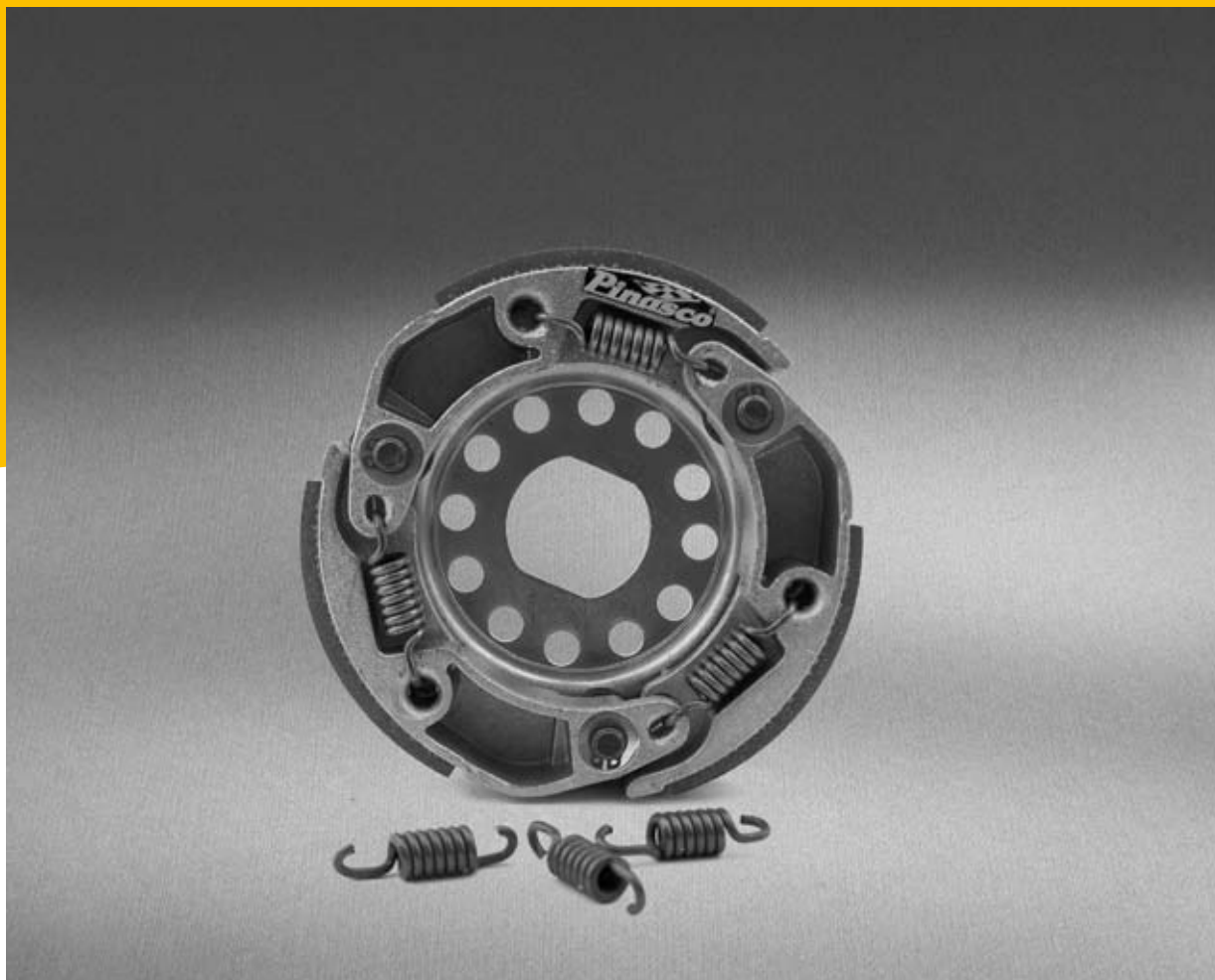

MARCA	MODELLO	CC	TEMPI	CODICE	
BRAND	MODEL	CC	STROKE	ITEM	
APRILIA	Amico *50	50	2	10090103	*
APRILIA	Area 51	50	2	10090103	-
APRILIA	Gulliver *50	50	2	10090103	*
APRILIA	Gulliver *50 LC	50	2	10090103	*
APRILIA	Habana *50	50	2	10090104	-
APRILIA	Mojito *50	50	2	10090104	-
APRILIA	Mojito *50 Custom	50	2	10090104	-
APRILIA	Rally *50	50	2	10090103	*
APRILIA	Rally *50 LC	50	2	10090103	*
APRILIA	Scarabeo *50 2T	50	2	10090103	*
APRILIA	Scarabeo *50 2T Street Carburatore	50	2	10090103	*
APRILIA	Scarabeo *50 4T	50	4	10090103	*
APRILIA	Scarabeo *50 DiTech / Aprilia	50	2	10090103	*
APRILIA	Scarabeo 100 2T	100	2	10090104	-
APRILIA	Sonic *50	50	2	10090103	-
APRILIA	Sonic *50 LC	50	2	10090103	-
APRILIA	SR *50 <-1993	50	2	10090102	-
APRILIA	SR *50 1994->	50	2	10090103	*
APRILIA	SR *50 2004 / Piaggio Carburatore	50	2	10090103	*
APRILIA	SR *50 DiTech / Aprilia	50	2	10090103	-
APRILIA	SR *50 DiTech GP1 / Piaggio Iniezione	50	2	10090103	*

MARCA	MODELLO	CC	TEMPI	CODICE	
BRAND	MODEL	CC	STROKE	ITEM	
APRILIA	SR *50 Netscaper LC	50	2	10090103	*
APRILIA	SR *50 R / Piaggio Carburatore	50	2	10090103	-
APRILIA	SR *50 R Factory	50	2	10090103	*
APRILIA	SR *50 Racing LC	50	2	10090103	*
APRILIA	SR *50 Replica LC	50	2	10090103	*
APRILIA	SR *50 Replica LC 2000 / Aprilia	50	2	10090103	*
APRILIA	SR *50 Stealth LC	50	2	10090103	*
APRILIA	SR *50 WWW	50	2	10090103	*
ATALA	Carosello *50	50	2	10090103	*
ATALA	Hacker *50	50	2	10090104	-
ATALA	Hacker *50 LC	50	2	10090104	-
BENELLI	491 Gt	50	2	10090103	*
BENELLI	491 Sport LC	50	2	10090103	*
BENELLI	K2 *50	50	2	10090103	*
BENELLI	K2 *50 LC	50	2	10090103	*
BENELLI	K2 100	100	2	10090104	-
BENELLI	Naked *50	50	2	10090103	*
BENELLI	Pepe *50	50	2	10090103	*
BENELLI	Pepe LX *50 euro 2	50	2	10090104	-
BENELLI	QuattroNove X *50 euro 2	50	2	10090104	-
BETA	Ark *50	50	2	10090103	*

MARCA	MODELLO	CC	TEMPI	CODICE		MARCA	MODELLO	CC	TEMPI	CODICE	
BRAND	MODEL	CC	STROKE	ITEM		BRAND	MODEL	CC	STROKE	ITEM	
BETA	Ark *50 LC	50	2	10090103	*	ITALJET	Velocifero	50	2	10090104	-
BETA	Chrono	50	2	10090103	*	ITALJET	Yankee	50	2	10090102	-
BETA	Eikon *50 LC	50	2	10090103	-	KEEWAY	F-ACT	50	2	10090104	-
BETA	Quadra	50	2	10090102	-	KEEWAY	Goccia	50	2	10090104	-
BETA	Tempo	50	2	10090102	-	KEEWAY	Hurricane	50	2	10090104	-
BSV	Ax	50	2	10090104	-	KEEWAY	Matrix	50	2	10090104	-
BSV	Dio Gp	50	2	10090103	*	KEEWAY	Pixel	50	2	10090104	-
BSV	Dio Zx (al 1993)	50	2	10090103	*	KEEWAY	RY8	50	2	10090104	-
BSV	Dio Zx (dal 1994)	50	2	10090103	*	KYMCO	Dink *50	50	2	10090103	*
BSV	Gz	50	2	10090104	-	KYMCO	Dink *50 LC	50	2	10090103	*
CAGIVA	City	50	2	10090103	*	KYMCO	Dj X	50	2	10090103	*
CPI	Aragon GP - Hussar - Oliver - Popcorn 2003 >	50	2	10090104	-	KYMCO	Dj Y	50	2	10090103	*
CPI	Hussar - Oliver - Popcorn < 2002	50	2	10090104	-	KYMCO	Heroism	50	2	10090103	*
CPI	Aragon GP - Hussar - Oliver - Popcorn > 2003	50	2	10090104	-	KYMCO	People *50	50	2	10090103	*
DERBI	Atlantis *50	50	2	10090104	-	KYMCO	People S *50 2T	50	2	10090103	*
DERBI	Atlantis *50 LC	50	2	10090104	-	KYMCO	People S *50 4T	50	4	10090103	*
DERBI	Bullet *50	50	2	10090103	*	KYMCO	Sniper *50 2T	50	2	10090103	*
DERBI	GP1 *50 LC	50	2	10090103	*	KYMCO	Super 9 - *50 LC	50	2	10090103	*
DERBI	GP1 *50 OPEN	50	2	10090103	-	KYMCO	Top Boy - Cobra *50	50	2	10090103	*
DERBI	GP1 *50 REVOLUTION	50	2	10090103	-	KYMCO	Vitality *50	50	4	10090103	*
DERBI	Hunter	50	2	10090104	-	LEM	Flash *50 2T	50	2	10090102	-
DERBI	Paddock *50	50	2	10090104	-	LEM	Ghibli *50 2T	50	2	10090102	-
DERBI	Paddock *50 LC	50	2	10090104	-	LEM	Tornado *50 2T	50	2	10090102	-
DERBI	Predator *50	50	2	10090104	-	MALAGUTI	Centro *50 2T	50	2	10090103	*
DERBI	Predator *50 LC	50	2	10090104	-	MALAGUTI	Ciak *50	50	2	10090103	*
EXPLORER	Cracker *50 2003>	50	2	10090104	-	MALAGUTI	Ciak 100	100	2	10090104	-
FANTIC	Big Wheel *50 2T	50	2	10090102	-	MALAGUTI	Ciak Master *50 4T euro 2	50	4	10090103	*
GARELLI	Gsp *50	50	2	10090104	-	MALAGUTI	Crosser CR1	50	2	10090104	-
GARELLI	Pony *50	50	2	10090102	-	MALAGUTI	F10	50	2	10090103	*
GARELLI	Sr *50	50	2	10090102	-	MALAGUTI	F10 Wap	50	2	10090104	-
GARELLI	Tiesse *50 R	50	2	10090104	-	MALAGUTI	F12 Digit KAT 50 LC	50	2	10090103	-
GILERA	DNA *50 LC	50	2	10090103	*	MALAGUTI	F12 Digit KAT 50 LC euro 2	50	2	10090103	-
GILERA	Easy Moving	50	2	10090103	*	MALAGUTI	F12 Phantom *50	50	2	10090103	*
GILERA	Ice *50 2T	50	2	10090103	*	MALAGUTI	F12 Phantom *50 LC	50	2	10090103	*
GILERA	Runner *50 LC < 2005	50	2	10090103	*	MALAGUTI	F12 Phantom 100	100	2	10090104	-
GILERA	Runner *50 PureJet <-2005	50	2	10090103	*	MALAGUTI	F12 R AIR euro 2	50	2	10090104	-
GILERA	Runner *50 PureJet 2006->	50	2	10090103	*	MALAGUTI	F12 R LC euro 2	50	2	10090103	-
GILERA	Runner *50 SP LC <-2005	50	2	10090103	*	MALAGUTI	F15 Firefox LC	50	2	10090103	*
GILERA	Runner *50 SP LC Carburatore 2006->	50	2	10090103	*	MALAGUTI	Yesterday	50	2	10090103	-
GILERA	Stalker	50	2	10090103	*	MBK	Active	50	2	10090103	*
GILERA	Storm	50	2	10090103	*	MBK	Booster *50 euro 0-1	50	2	10090103	*
GILERA	Typhoon	50	2	10090103	*	MBK	Booster *50 Naked euro 2	50	2	10090103	*
GILERA	Typhoon *50 X	50	2	10090103	*	MBK	Booster *50 NG euro 0-1	50	2	10090103	*
HONDA	Bali *50	50	2	10090103	*	MBK	Booster *50 NG euro 2	50	2	10090103	*
HONDA	Dio G	50	2	10090103	*	MBK	Booster *50 Spirit euro 0-1	50	2	10090103	*
HONDA	Dio Zx <-1993	50	2	10090103	*	MBK	Booster 100 2T	100	2	10090104	-
HONDA	Dio Zx 1994->	50	2	10090103	*	MBK	Flipper	50	2	10090103	-
HONDA	SFX *50	50	2	10090103	*	MBK	Forte	50	2	10090103	*
HONDA	SH *50 - 1996->	50	2	10090103	*	MBK	Hot Champ	50	2	10090103	*
HONDA	Shadow *50	50	2	10090103	-	MBK	Mach G 50	50	2	10090103	-
HONDA	Sky *50	50	2	10090103	*	MBK	Mach G 50 LC	50	2	10090103	-
HONDA	Sxr	50	2	10090103	-	MBK	Nitro *50	50	2	10090103	*
HONDA	X8R X-S	50	2	10090103	*	MBK	Ovetto *50	50	2	10090103	*
HSC	Sc 01L Dio Zx	50	2	10090103	-	MBK	Ovetto 100	100	2	10090104	-
HUPPER	Montecarlo 30 2T	50	2	10090104	-	MBK	Rocket	50	2	10090103	*
ITALJET	Bazooka	50	2	10090102	-	MBK	Rocket 50 euro 2	50	2	10090103	*
ITALJET	Dragster *50 LC	50	2	10090103	-	MBK	Sorriso *50 2T <-1995	50	2	10090102	-
ITALJET	Formula *50	50	2	10090104	-	MBK	Sorriso *50 2T 1996->	50	2	10090103	-
ITALJET	Formula *50 LC	50	2	10090104	-	MBK	Stunt *50 2T euro 0-1	50	2	10090103	*
ITALJET	Jet Set *50	50	2	10090103	-	MBK	Stunt *50 2T euro 2	50	2	10090103	*
ITALJET	Pista	50	2	10090102	-	MBK	Target *50 2T	50	2	10090102	-
ITALJET	Pista 2	50	2	10090102	-	P.G.O.	Big Max *50 2T	50	2	10090103	-
ITALJET	Reporter	50	2	10090102	-	PEUGEOT	Buxy - Buxy Rs *50 2T	50	2	10090103	*
ITALJET	Scoop	50	2	10090102	-	PEUGEOT	Elyseo *50 2T	50	2	10090103	*
ITALJET	Torpedo *50 2T	50	2	10090104	-	PEUGEOT	Jet Force C-Tech *50 2T	50	2	10090103	*
ITALJET	Torpedo *50 2T New	50	2	10090103	-	PEUGEOT	Jet Force TSDI *50 2T	50	2	10090103	*



MARCA	MODELLO	CC	TEMPI	CODICE		MARCA	MODELLO	CC	TEMPI	CODICE	
BRAND	MODEL	CC	STROKE	ITEM		BRAND	MODEL	CC	STROKE	ITEM	
PEUGEOT	Looxor TSDI *50 2T	50	2	10090103	*	PIAGGIO	Zip SP LC ->2000	50	2	10090103	*
PEUGEOT	Ludix *50 2T	50	2	10090103	*	PIAGGIO	Zip SP LC 2001->	50	2	10090103	*
PEUGEOT	Ludix Blaster *50 2T	50	2	10090103	*	RIZZATO	Vamos	50	2	10090104	-
PEUGEOT	Metal-X *50 2T	50	2	10090103	*	SUZUKI	Address Ah 50 2T	50	2	10090104	-
PEUGEOT	Speedake *50 2T	50	2	10090103	-	SUZUKI	AP *50 2T	50	2	10090104	-
PEUGEOT	Speedfight *50 2T	50	2	10090103	*	SUZUKI	Estilite - UF 50 2T	50	2	10090104	-
PEUGEOT	Speedfight *50 2T LC	50	2	10090103	*	SUZUKI	Katana *50 - 1999->	50	2	10090104	-
PEUGEOT	Squab *50 2T	50	2	10090103	*	SUZUKI	Katana *50 <-1998)	50	2	10090104	-
PEUGEOT	Sv Geo *50 2T	50	2	10090103	*	SUZUKI	Katana *50 LC <-1998	50	2	10090104	-
PEUGEOT	Trekker *50 2T	50	2	10090103	*	SUZUKI	Katana *50 LC 1999->	50	2	10090104	-
PEUGEOT	Vivacity *50 KAT 2T	50	2	10090103	*	SUZUKI	Sepia *50 2T	50	2	10090104	-
PEUGEOT	X-Fight *50 2T	50	2	10090103	*	SUZUKI	Sepia *50 ZZ 2T	50	2	10090104	-
PEUGEOT	X-Fight *50 2T LC	50	2	10090103	-	SUZUKI	Street Magic	50	2	10090104	-
PEUGEOT	Zenith *50 2T	50	2	10090103	*	SUZUKI	Zillion *50 2T	50	2	10090104	-
PIAGGIO	Diesis *50 2T	50	2	10090103	*	YAMAHA	Aerox *50 euro 0-1	50	2	10090103	*
PIAGGIO	Fly *50 2T	50	2	10090103	-	YAMAHA	Aerox *50 euro 2	50	2	10090103	*
PIAGGIO	Fly *50 4T	50	4	10090103	*	YAMAHA	Aerox 100 2T	100	2	10090104	-
PIAGGIO	Free *50 2T	50	2	10090103	-	YAMAHA	Axis *50 2T	50	2	10090104	-
PIAGGIO	Liberty *50 2T	50	2	10090103	*	YAMAHA	Beluga *50 2T	50	2	10090102	-
PIAGGIO	Liberty *50 4T	50	4	10090103	*	YAMAHA	Breeze *50 2T	50	2	10090104	-
PIAGGIO	NRG *50 LC	50	2	10090103	*	YAMAHA	BW'S *50 euro 0-1	50	2	10090103	*
PIAGGIO	NRG Extreme	50	2	10090103	-	YAMAHA	BW'S *50 NG euro 0-1	50	2	10090103	*
PIAGGIO	NRG Extreme LC	50	2	10090103	-	YAMAHA	BW'S *50 NG euro 2	50	2	10090103	*
PIAGGIO	NRG Mc2 LC <-1997	50	2	10090103	*	YAMAHA	BW'S *50 Original / Naked 2T euro 2 > 2010	50	2	10090103	*
PIAGGIO	NRG Mc2 LC 1998->	50	2	10090103	*	YAMAHA	BW'S 100 2T	100	2	10090104	-
PIAGGIO	NRG Mc3 DD LC	50	2	10090103	*	YAMAHA	CRZ *50 2T	50	2	10090102	-
PIAGGIO	NRG Mc3 DT	50	2	10090103	*	YAMAHA	CT *50 2T	50	2	10090102	-
PIAGGIO	NRG Mc3 PureJet LC	50	2	10090103	*	YAMAHA	Jog *50	50	2	10090103	*
PIAGGIO	NRG Power DD LC	50	2	10090103	*	YAMAHA	Jog *50 ER	50	2	10090103	*
PIAGGIO	NRG Power DT LC	50	2	10090103	-	YAMAHA	Jog *50 R	50	2	10090103	-
PIAGGIO	NRG Power PureJet	50	2	10090103	*	YAMAHA	Jog *50 RR	50	2	10090103	*
PIAGGIO	NTT LC	50	2	10090103	*	YAMAHA	Jog *50 Z	50	2	10090103	*
PIAGGIO	Quartz LC	50	2	10090103	*	YAMAHA	Neo's *50 2T	50	2	10090103	*
PIAGGIO	Sfera *50	50	2	10090103	*	YAMAHA	Neo's 100 2T	100	2	10090104	-
PIAGGIO	Sfera *50 Rst	50	2	10090103	*	YAMAHA	Slider *50 2T	50	2	10090103	-
PIAGGIO	Typhoon *50 2T 2007->2010	50	2	10090103	-	YAMAHA	Spy *50 2T	50	2	10090103	*
PIAGGIO	Typhoon *50 2T euro 2 - 2011->	50	2	10090103	-	YAMAHA	Vino *50 2T	50	2	10090103	*
PIAGGIO	Zip *50 2T	50	2	10090103	*	YAMAHA	Why *50 2T	50	2	10090103	-
PIAGGIO	Zip *50 2T / 2000	50	2	10090103	*	YAMAHA	Zest *50 2T	50	2	10090104	-
PIAGGIO	Zip *50 4T	50	4	10090103	*	YAMAHA	Zuma *50 2T	50	2	10090103	*
PIAGGIO	Zip Fast Rider	50	2	10090103	*						

OPTIPULL Semipuleggia Condotta Mobile OPTIPULL Mobile Pulley System

Speciale puleggia condotta con camme di apertura riviste per ottimizzare il funzionamento della trasmissione ed eliminare tutti i dannosi cali di giri e di potenza trasmessa alla ruota: ogni correttore di coppia è dotato di cave con due diverse angolazioni.

Special driven pulley with opening cams to optimize the operation of the transmission and to eliminate all harmful falloffs in engine speed and power transmitted to the wheel: each torque adjuster is fitted with guides with two different runnels.



* Correttore
di coppia Ø33
COD. 10404022
Correttore
di coppia Ø34
COD. 10404024

* Torque adjuster Ø33
ITEM 10404022
Torque adjuster Ø34
ITEM 10404024

MARCA	MODELLO	CC	TEMPI	CODICE	MARCA	MODELLO	CC	TEMPI	CODICE
BRAND	MODEL	CC	STROKE	ITEM	BRAND	MODEL	CC	STROKE	ITEM
APRILIA	Amico *50	50	2	10404024 *	BENELLI	Pepe *50	50	2	10404024 *
APRILIA	Area 51	50	2	10404024	BENELLI	Pepe LX *50 euro 2	50	2	10404024
APRILIA	Gulliver *50	50	2	10404024 *	BENELLI	QuattroNove X *50 euro 2	50	2	10404024
APRILIA	Gulliver *50 LC	50	2	10404024 *	BETA	Ark *50	50	2	10404024 *
APRILIA	Mojito *50 Custom	50	2	10404095	BETA	Ark *50 LC	50	2	10404024 *
APRILIA	Rally *50	50	2	10404024 *	BETA	Chrono	50	2	10404024 *
APRILIA	Rally *50 LC	50	2	10404024 *	BETA	Eikon *50 LC	50	2	10404024
APRILIA	Scarabeo *50 2T	50	2	10404024 *	BETA	Quadra	50	2	10404022
APRILIA	Scarabeo *50 2T Street Carburatore	50	2	10404095	BETA	Tempo	50	2	10404022
APRILIA	Scarabeo *50 4T	50	4	10404095	BSV	Dio Gp	50	2	10404077
APRILIA	Scarabeo *50 4T Street	50	4	10404095	BSV	Dio Zx (al 1993)	50	2	10404077
APRILIA	Scarabeo 100 2T	100	2	10404022	BSV	Dio Zx (dal 1994)	50	2	10404077
APRILIA	Sonic *50	50	2	10404024	CPI	Aragon GP - Hussar - Oliver - Popcorn 2003 >	50	2	10404024 *
APRILIA	Sonic *50 LC	50	2	10404024	CPI	Hussar - Oliver - Popcorn < 2002	50	2	10404022
APRILIA	Sportcity One *50 4T	50	4	10404095	CPI	Aragon GP - Hussar - Oliver - Popcorn > 2003	50	2	10404024 *
APRILIA	SR *50 <-1993	50	2	10404022	DERBI	Bullet *50	50	2	10404095
APRILIA	SR *50 1994->	50	2	10404024 *	DERBI	GP1 *50 LC	50	2	10404095
APRILIA	SR *50 2004 / Piaggio Carburatore	50	2	10404095	DERBI	GP1 *50 OPEN	50	2	10404095
APRILIA	SR *50 DiTech GP1 / Piaggio Iniezione	50	2	10404095	DERBI	GP1 *50 REVOLUTION	50	2	10404095
APRILIA	SR *50 Netscaper LC	50	2	10404024	EXPLORER	Cracker *50 2003>	50	2	10404024 *
APRILIA	SR *50 R / Piaggio Carburatore	50	2	10404095	FANTIC	Big Wheel *50 2T	50	2	10404022
APRILIA	SR *50 R Factory	50	2	10404095	GARELLI	Gsp *50	50	2	10404024
APRILIA	SR *50 Racing LC	50	2	10404024	GARELLI	Pony *50	50	2	10404022
APRILIA	SR *50 Replica LC	50	2	10404024 *	GARELLI	Sr *50	50	2	10404022
APRILIA	SR *50 Stealth LC	50	2	10404024	GARELLI	Tiesse *50 R	50	2	10404024 *
APRILIA	SR *50 WWW	50	2	10404024	GARELLI	VIP	50	4	10404077
ATALA	Carosello *50	50	2	10404024 *	GILERA	DNA *50 LC	50	2	10404095
BENELLI	491 Gt	50	2	10404024 *	GILERA	Easy Moving	50	2	10404093
BENELLI	491 Sport LC	50	2	10404024 *	GILERA	Ice *50 2T	50	2	10404095
BENELLI	K2 *50	50	2	10404024 *	GILERA	Runner *50 LC < 2005	50	2	10404095
BENELLI	K2 *50 LC	50	2	10404024 *	GILERA	Runner *50 PureJet <-2005	50	2	10404095
BENELLI	K2 100	100	2	10404022	GILERA	Runner *50 PureJet 2006->	50	2	10404095
BENELLI	Naked *50	50	2	10404024	GILERA	Runner *50 SP LC <-2005	50	2	10404095

MARCA	MODELLO	CC	TEMPI	CODICE
BRAND	MODEL	CC	STROKE	ITEM
GILERA	Runner *50 SP LC Carburatore 2006->	50	2	10404095
GILERA	Stalker	50	2	10404095
GILERA	Storm	50	2	10404093
GILERA	Typhoon	50	2	10404093
GILERA	Typhoon *50 X	50	2	10404095
HONDA	Bali *50	50	2	10404077
HONDA	Dio G	50	2	10404077
HONDA	Dio Zx <-1993	50	2	10404077
HONDA	Dio Zx 1994->	50	2	10404077
HONDA	SFX *50	50	2	10404077
HONDA	SH *50 - 1996->	50	2	10404077
HONDA	Shadow *50	50	2	10404077
HONDA	Sky *50	50	2	10404077
HONDA	Sxr	50	2	10404077
HONDA	X8R X-S	50	2	10404077
HSC	Sc 01L Dio Zx	50	2	10404077
HUPPER	Montecarlo 30 2T	50	2	10404024 *
ITALJET	Bazooka	50	2	10404022
ITALJET	Dragster *50 LC	50	2	10404024
ITALJET	Jet Set *50	50	2	10404095
ITALJET	Millennium 100	100	2	10404022
ITALJET	Pista	50	2	10404022
ITALJET	Pista 2	50	2	10404022
ITALJET	Reporter	50	2	10404022
ITALJET	Scoop	50	2	10404022
ITALJET	Torpedo *50 2T New	50	2	10404095
ITALJET	Yankee	50	2	10404022
KEEWAY	F-ACT	50	2	10404022
KEEWAY	Goccia	50	2	10404024 *
KEEWAY	Hurricane	50	2	10404022
KEEWAY	Matrix	50	2	10404022
KEEWAY	Pixel	50	2	10404024 *
KEEWAY	RY8	50	2	10404024 *
KYMCO	CX	50	2	10404077
KYMCO	Dink *50	50	2	10404077
KYMCO	Dj Y	50	2	10404077
KYMCO	People *50	50	2	10404077
KYMCO	People *50 4T euro 2	50	4	10404077
KYMCO	People S *50 2T	50	2	10404077
KYMCO	People S *50 4T	50	4	10404077
KYMCO	Sniper *50 2T	50	2	10404077
KYMCO	Super 8 - *50 4T euro 2	50	4	10404077
KYMCO	Top Boy - Cobra *50	50	2	10404077
KYMCO	Vitality *50	50	4	10404077
LEM	Flash *50 2T	50	2	10404022
LEM	Ghibli *50 2T	50	2	10404022
LEM	Tornado *50 2T	50	2	10404022
MALAGUTI	Centro *50 2T	50	2	10404024 *
MALAGUTI	Ciak *50	50	2	10404024 *
MALAGUTI	Ciak Master *50 4T euro 2	50	4	10404095
MALAGUTI	F10	50	2	10404024 *
MALAGUTI	F10 Wap	50	2	10404024 *
MALAGUTI	F12 Digit KAT 50 LC	50	2	10404024 *
MALAGUTI	F12 Digit KAT 50 LC euro 2	50	2	10404024 *
MALAGUTI	F12 Phantom *50	50	2	10404024 *
MALAGUTI	F12 Phantom *50 LC	50	2	10404024 *
MALAGUTI	F12 R AIR euro 2	50	2	10404024 *
MALAGUTI	F12 R LC euro 2	50	2	10404024 *
MALAGUTI	F15 Firefox LC	50	2	10404024 *
MALAGUTI	Yesterday	50	2	10404024 *
MBK	Active	50	2	10404024 *
MBK	Booster *50 euro 0-1	50	2	10404024 *
MBK	Booster *50 NG euro 0-1	50	2	10404024 *
MBK	Booster *50 Spirit euro 0-1	50	2	10404024 *
MBK	Booster 100 2T	100	2	10404022
MBK	Evolis	50	2	10404024 *
MBK	Fizz	50	2	10404024 *
MBK	Flipper	50	2	10404024 *
MBK	Forte	50	2	10404024 *
MBK	Hot Champ	50	2	10404024 *
MBK	Mach G 50	50	2	10404024 *
MBK	Mach G 50 LC	50	2	10404024 *
MBK	Nitro *50	50	2	10404024 *
MBK	Nitro 100	100	2	10404022
MBK	Ovetto *50	50	2	10404024 *
MBK	Ovetto 100	100	2	10404022
MBK	Rocket	50	2	10404024 *

MARCA	MODELLO	CC	TEMPI	CODICE
BRAND	MODEL	CC	STROKE	ITEM
MBK	Sorriso *50 2T <-1995	50	2	10404022
MBK	Sorriso *50 2T 1996->	50	2	10404024 *
MBK	Stunt *50 2T euro 0-1	50	2	10404024 *
MBK	Target *50 2T	50	2	10404022
P.G.O.	Big Max *50 2T	50	2	10404077
PEUGEOT	Buxy - Buxy Rs *50 2T	50	2	10404077
PEUGEOT	Elyseo *50 2T	50	2	10404077
PEUGEOT	Jet Force TSDI *50 2T	50	2	10404077
PEUGEOT	Loxor TSDI *50 2T	50	2	10404077
PEUGEOT	Ludix *50 2T	50	2	10404077
PEUGEOT	Ludix Blaster *50 2T	50	2	10404077
PEUGEOT	Metal-X *50 2T	50	2	10404077
PEUGEOT	Speedake *50 2T	50	2	10404077
PEUGEOT	Speedfight *50 2T	50	2	10404077
PEUGEOT	Speedfight *50 2T LC	50	2	10404077
PEUGEOT	Squab *50 2T	50	2	10404077
PEUGEOT	Sv Geo *50 2T	50	2	10404077
PEUGEOT	Trekker *50 2T	50	2	10404077
PEUGEOT	Vivacity *50 KAT 2T	50	2	10404077
PEUGEOT	X-Fight *50 2T	50	2	10404077
PEUGEOT	X-Fight *50 2T LC	50	2	10404077
PEUGEOT	Zenith *50 2T	50	2	10404077
PIAGGIO	Diesis *50 2T	50	2	10404095
PIAGGIO	Fly *50 2T	50	2	10404095
PIAGGIO	Fly *50 4T	50	4	10404095
PIAGGIO	Free *50 2T	50	2	10404093
PIAGGIO	Liberty *50 2T	50	2	10404095
PIAGGIO	Liberty *50 4T	50	4	10404095
PIAGGIO	Liberty S 50 4T	50	4	10404095
PIAGGIO	NRG *50 LC	50	2	10404093
PIAGGIO	NRG Extreme	50	2	10404095
PIAGGIO	NRG Extreme LC	50	2	10404095
PIAGGIO	NRG Mc2 LC <-1997	50	2	10404093
PIAGGIO	NRG Mc2 LC 1998->	50	2	10404095
PIAGGIO	NRG Mc3 DD LC	50	2	10404095
PIAGGIO	NRG Mc3 DT	50	2	10404095
PIAGGIO	NRG Mc3 PureJet LC	50	2	10404095
PIAGGIO	NRG Power DD LC	50	2	10404095
PIAGGIO	NRG Power DT LC	50	2	10404095
PIAGGIO	NRG Power PureJet	50	2	10404095
PIAGGIO	NTT LC	50	2	10404093
PIAGGIO	Quartz LC	50	2	10404093
PIAGGIO	Sfera *50	50	2	10404093
PIAGGIO	Sfera *50 Rst	50	2	10404093
PIAGGIO	Typhoon *50 2T 2007->2010	50	2	10404095
PIAGGIO	Typhoon *50 2T euro 2 - 2011->	50	2	10404095
PIAGGIO	Zip *50 2T / 2000	50	2	10404095
PIAGGIO	Zip *50 4T	50	4	10404095
PIAGGIO	Zip Fast Rider	50	2	10404093
PIAGGIO	Zip SP LC ->2000	50	2	10404093
PIAGGIO	Zip SP LC 2001->	50	2	10404095
SYM	DD *50 2T	50	2	10404077
YAMAHA	Aerox *50 euro 0-1	50	2	10404024 *
YAMAHA	Aerox *50 euro 2	50	2	10404024
YAMAHA	Aerox 100 2T	100	2	10404022
YAMAHA	Axis *50 2T	50	2	10404022
YAMAHA	Beluga *50 2T	50	2	10404022
YAMAHA	Breeze *50 2T	50	2	10404024 *
YAMAHA	BW'S *50 euro 0-1	50	2	10404024 *
YAMAHA	BW'S *50 NG euro 0-1	50	2	10404024 *
YAMAHA	BW'S 100 2T	100	2	10404022
YAMAHA	CRZ *50 2T	50	2	10404022
YAMAHA	CT *50 2T	50	2	10404022
YAMAHA	Jog *50	50	2	10404024 *
YAMAHA	Jog *50 ER	50	2	10404024 *
YAMAHA	Jog *50 R	50	2	10404024
YAMAHA	Jog *50 RR	50	2	10404024
YAMAHA	Jog *50 Z	50	2	10404024 *
YAMAHA	Neo's *50 2T	50	2	10404024 *
YAMAHA	Neo's 100 2T	100	2	10404022
YAMAHA	Slider *50 2T	50	2	10404024 *
YAMAHA	Spy *50 2T	50	2	10404024 *
YAMAHA	Vino *50 2T	50	2	10404024 *
YAMAHA	Why *50 2T	50	2	10404024 *
YAMAHA	Zest *50 2T	50	2	10404024 *
YAMAHA	Zuma *50 2T	50	2	10404024 *

Ingranaggi di Trasmissione Transmission Gears

Ingranaggi di trasmissione a denti dritti rasati con rapporto calcolato per motori elaborati. Realizzati in acciaio cementato, rettificato e temprato, sono estremamente resistenti e silenziosi.

Transmission gears with trimmed straight teeth and ratio for modified engines. Made from casehardened, ground and hardened steel, they are extremely resistant and silent in operation.

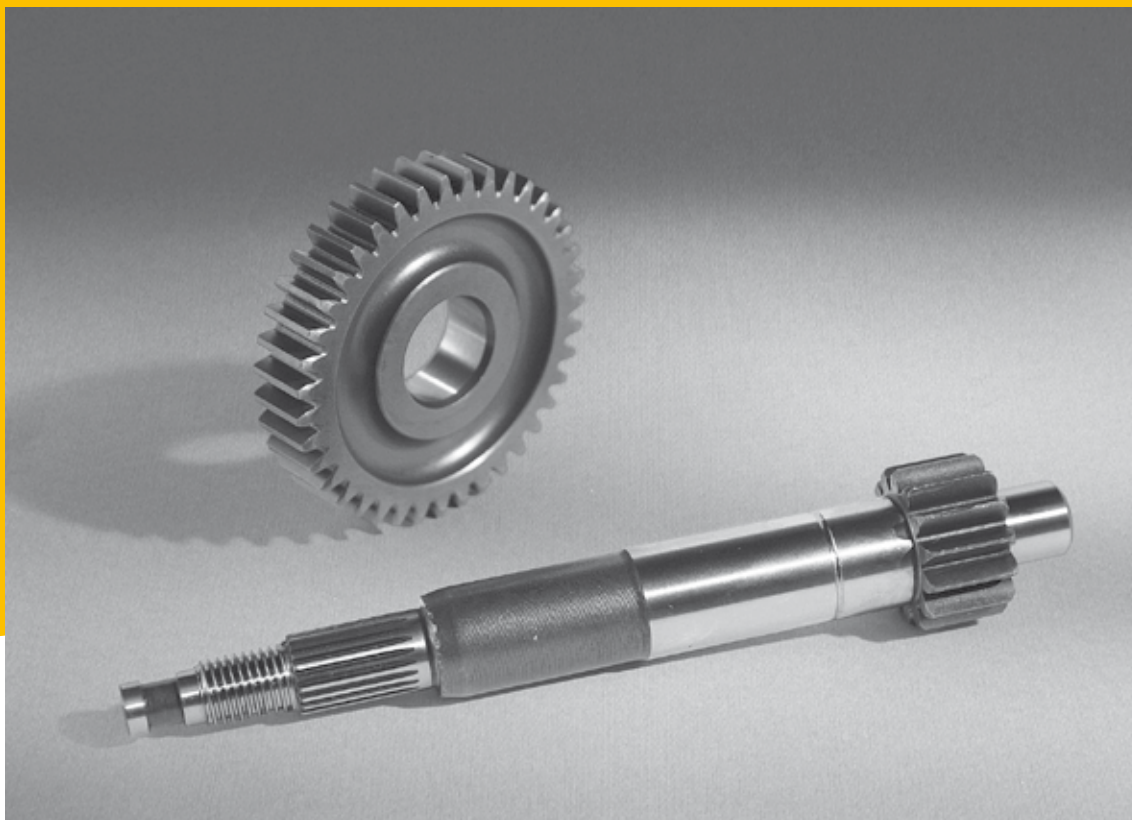

MARCA	MODELLO	CC	TEMPI	CODICE	Z
BRAND	MODEL	CC	STROKE	ITEM	Z
APRILIA	Amico *50	50	2	10274625	16-40
APRILIA	Area 51	50	2	10274661	13-44
APRILIA	Atlantic 200	200	4	10274654	16-42
APRILIA	Gulliver *50	50	2	10274661	13-44
APRILIA	Gulliver *50 LC	50	2	10274661	13-44
APRILIA	Habana *50	50	2	10274633	15-40
APRILIA	Leonardo 250	250	4	10274662	17-37
APRILIA	Mojito *50	50	2	10274633	15-40
APRILIA	Mojito 125	125	4	10274654	16-42
APRILIA	Rally *50	50	2	10274661	13-44
APRILIA	Rally *50 LC	50	2	10274661	13-44
APRILIA	Scarabeo *50 2T	50	2	10274661	13-44
APRILIA	Scarabeo *50 2T Street Carburatore	50	2	10274663*	15-55
APRILIA	Scarabeo *50 4T	50	4	10274663*	15-55
APRILIA	Scarabeo *50 DiTech / Aprilia	50	2	10274633	15-40
APRILIA	Sonic *50	50	2	10274645	15-41
APRILIA	Sonic *50 LC	50	2	10274645	15-41
APRILIA	Sportcity One *50 4T	50	4	10274663*	15-55
APRILIA	SR *50 <-1993	50	2	10274690	14-42
APRILIA	SR *50 1994->	50	2	10274661	13-44
APRILIA	SR *50 2004 / Piaggio Carburatore	50	2	10274652	14-39
APRILIA	SR *50 DiTech / Aprilia	50	2	10274633	15-40
APRILIA	SR *50 DiTech GP1 / Piaggio Iniezione	50	2	10274652	14-39
APRILIA	SR *50 Netscaper LC	50	2	10274661	13-44
APRILIA	SR *50 R / Piaggio Carburatore	50	2	10274652	14-39
APRILIA	SR *50 R Factory	50	2	10274652	14-39
APRILIA	SR *50 Racing LC	50	2	10274661	13-44
APRILIA	SR *50 Replica LC	50	2	10274661	13-44

MARCA	MODELLO	CC	TEMPI	CODICE	Z
BRAND	MODEL	CC	STROKE	ITEM	Z
APRILIA	SR *50 Replica LC 2000 / Aprilia	50	2	10274633	15-40
APRILIA	SR *50 Stealth LC	50	2	10274661	13-44
APRILIA	SR *50 WWW	50	2	10274661	13-44
APRILIA	SR 125	125	2	10274612	16-40
APRILIA	SR 150	150	2	10274612	16-40
ATALA	Carosello *50	50	2	10274690	14-42
ATALA	Hacker *50	50	2	10274660	15-34
ATALA	Hacker *50 LC	50	2	10274660	15-34
BENELLI	491 Gt	50	2	10274661	13-44
BENELLI	491 Sport LC	50	2	10274661	13-44
BENELLI	K2 *50	50	2	10274661	13-44
BENELLI	K2 *50 LC	50	2	10274661	13-44
BENELLI	Naked *50	50	2	10274661	13-44
BENELLI	Pepe *50	50	2	10274690	14-42
BENELLI	Pepe LX *50 euro 2	50	2	10274664	14-42
BENELLI	QuattroNove X *50 euro 2	50	2	10274664	14-42
BENELLI	Velvet 250	250	4	10274662	17-37
BETA	Ark *50	50	2	10274661	13-44
BETA	Ark *50 LC	50	2	10274661	13-44
BETA	Chrono	50	2	10274690	14-42
BETA	Eikon *50 LC	50	2	10274661	13-44
BETA	Quadra	50	2	10274661	13-44
BETA	Tempo	50	2	10274690	14-42
BSV	Ax	50	2	10274645	15-41
BSV	Dio Gp	50	2	10274640	16-32
BSV	Dio Sp	50	2	10274640	16-32
BSV	Dio Zx (al 1993)	50	2	10274640	16-32
BSV	Dio Zx (dal 1994)	50	2	10274640	16-32
BSV	Gz	50	2	10274645	15-41
CAGIVA	City	50	2	10274685	18-40
CAGIVA	Progress	50	2	10274634	15-43
CPI	Aragon GP - Hussar - Oliver - Popcorn 2003 >	50	2	10274664	14-42
CPI	Aragon GP - Hussar - Oliver - Popcorn > 2003	50	2	10274664	14-42
DERBI	Atlantis *50	50	2	10274634	15-43
DERBI	Atlantis *50 LC	50	2	10274634	15-43
DERBI	Bullet *50	50	2	10274652	14-39
DERBI	GP1 *50 LC	50	2	10274652	14-39
DERBI	GP1 *50 OPEN	50	2	10274652	14-39
DERBI	GP1 *50 REVOLUTION	50	2	10274652	14-39
DERBI	Paddock *50 LC	50	2	10274634	15-43
DERBI	Predator *50	50	2	10274634	15-43
DERBI	Predator *50 LC	50	2	10274634	15-43
EXPLORER	Cracker *50 2003->	50	2	10274664	14-42
FANTIC	Big Wheel *50 2T	50	2	10274625	16-40
GARELLI	Pony *50	50	2	10274620	17-40
GARELLI	Sr *50	50	2	10274620	17-40
GARELLI	Tiesse *50 R	50	2	10274664	14-42
GILERA	Easy Moving	50	2	10274691 cal. 17,67 10274675 cal. 18,00	16-37
GILERA	Ice *50 2T	50	2	10274652	14-39
GILERA	Runner *50 LC < 2005	50	2	10274652 cal. 17,67	14-39
GILERA	Runner *50 PureJet <-2005	50	2	10274652	14-39
GILERA	Runner *50 PureJet 2006->	50	2	10274652	14-39
GILERA	Runner *50 SP LC <-2005	50	2	10274652 cal. 17,67	14-39
GILERA	Runner *50 SP LC Carburatore 2006->	50	2	10274652	14-39
GILERA	Runner FX 125	125	2	10274672	15-41
GILERA	Runner FXR 180	180	2	10274682	14-43
GILERA	Runner VX 125 <-2005	125	4	10274654	16-42
GILERA	Runner VXR 180	180	4	10274654	16-42
GILERA	Runner VXR 200 - 2006->	200	4	10274654	16-42
GILERA	Stalker	50	2	10274652 cal. 17,67	14-39
GILERA	Storm	50	2	10274621 cal. 17,67 10274611 cal. 18,00	14-39
GILERA	Typhoon	50	2	10274621 cal. 17,67 10274611 cal. 18,00	14-39
GILERA	Typhoon *50 X	50	2	10274652 cal. 17,67	14-39
GILERA	Typhoon 125	125	2	10274622	15-41
GILERA	Typhoon 125 X	125	2	10274672	15-41
HONDA	@125	125	4	10274683	15-39





MARCA	MODELLO	CC	TEMPI	CODICE	Z
BRAND	MODEL	CC	STROKE	ITEM	Z
HONDA	@150	150	4	10274684	16-38
HONDA	Bali *50	50	2	10274695	17-39
HONDA	Dio G	50	2	10274640	16-32
HONDA	Dio Sp	50	2	10274640	16-32
HONDA	Dio Sr	50	2	10274640	16-32
HONDA	Dio Zx <-1993	50	2	10274640	16-32
HONDA	Dio Zx 1994->	50	2	10274640	16-32
HONDA	Dylan 125	125	4	10274683	15-39
HONDA	Dylan 150	150	4	10274684	16-38
HONDA	Foresight 250	250	4	10274692	17-37
HONDA	Forza 250 - 2001->	250	4	10274692	17-37
HONDA	Lead	50	2	10274630	16-32
HONDA	PS 150 i.e.	150	4	10274684	16-38
HONDA	SFX *50	50	2	10274642	18-37
HONDA	SH *50 - 1996->	50	2	10274632	16-40
HONDA	SH *50 <-1995	50	2	10274610	16-32
HONDA	SH 150	150	4	10274683	15-39
HONDA	Sky *50	50	2	10274632	16-40
HONDA	Sxr	50	2	10274642	18-37
HONDA	Vision	50	2	10274635	16-32
HONDA	Vision Met-In	50	2	10274635	16-32
HONDA	X8R X-S	50	2	10274632	16-40
HSC	Sc 01	50	2	10274640	16-32
HSC	Sc 01L Dio Zx	50	2	10274640	16-32
HUPPER	Montecarlo 30 2T	50	2	10274664	14-42
ITALJET	Bazooka	50	2	10274620	17-40
ITALJET	Dragster *50 LC	50	2	10274661	13-44
ITALJET	Dragster 125	125	2	10274672	15-41
ITALJET	Dragster 180	180	2	10274682	14-43
ITALJET	Formula *50	50	2	10274660	15-34
ITALJET	Formula *50 LC	50	2	10274660	15-34
ITALJET	Jet Set *50	50	2	10274652	14-39
ITALJET	Jupiter 250	250	4	10274662	17-37
ITALJET	Pista	50	2	10274620	17-40
ITALJET	Pista 2	50	2	10274625	16-40
ITALJET	Reporter	50	2	10274620	17-40
ITALJET	Scoop	50	2	10274625	16-40
ITALJET	Torpedo *50 2T	50	2	10274660	15-34
ITALJET	Velocifero	50	2	10274660	15-34
ITALJET	Yankee	50	2	10274625	16-40
KEEWAY	F-ACT	50	2	10274664	14-42
KEEWAY	Goccia	50	2	10274664	14-42
KEEWAY	Hurricane	50	2	10274645	15-41
KEEWAY	Matrix	50	2	10274664	14-42
KEEWAY	Pixel	50	2	10274664	14-42
KEEWAY	RY8	50	2	10274664	14-42
KYMCO	CX	50	2	10274635	16-32
KYMCO	Dink *50	50	2	10274644	15-44
KYMCO	Dj X	50	2	10274635	16-32
KYMCO	Dj Y	50	2	10274640	16-32
KYMCO	Heroism	50	2	10274631	18-41
KYMCO	Sniper *50 2T	50	2	10274631	18-41
KYMCO	Top Boy - Cobra *50	50	2	10274644	15-44
LEM	Flash *50 2T	50	2	10274620	17-40
LEM	Ghibli *50 2T	50	2	10274620	17-40
LEM	Tornado *50 2T	50	2	10274620	17-40
MALAGUTI	Centro *50 2T	50	2	10274690	14-42
MALAGUTI	Ciak *50	50	2	10274690	14-42
MALAGUTI	Ciak Master *50 4T euro 2	50	4	10274663	15-55
MALAGUTI	Crosser CR1	50	2	10274660	15-34
MALAGUTI	F10	50	2	10274645	15-41
MALAGUTI	F10 Wap	50	2	10274645	15-41
MALAGUTI	F12 Digit KAT 50 LC	50	2	10274673*	13-44
MALAGUTI	F12 Digit KAT 50 LC euro 2	50	2	10274673*	13-44
MALAGUTI	F12 Phantom *50	50	2	10274661	13-44
MALAGUTI	F12 Phantom *50 LC	50	2	10274661	13-44
MALAGUTI	F12 Phantom Max 200	200	4	10274654	16-42
MALAGUTI	F12 R AIR euro 2	50	2	10274664	14-42

MARCA	MODELLO	CC	TEMPI	CODICE	Z
BRAND	MODEL	CC	STROKE	ITEM	Z
MALAGUTI	F12 R LC euro 2	50	2	10274673*	13-44
MALAGUTI	F15 Firefox LC	50	2	10274661	13-44
MALAGUTI	Madison 180	180	4	10274654	16-42
MALAGUTI	Madison 200	200	4	10274654	16-42
MALAGUTI	Madison 250 (Motore Yamaha)	250	4	10274662	17-37
MALAGUTI	Yesterday	50	2	10274645	15-41
MBK	Active	50	2	10274620	17-40
MBK	Booster *50 euro 0-1	50	2	10274625	16-40
MBK	Booster *50 Naked euro 2	50	2	10274625	16-40
MBK	Booster *50 NG euro 0-1	50	2	10274625	16-40
MBK	Booster *50 NG euro 2	50	2	10274625	16-40
MBK	Booster *50 Spirit euro 0-1	50	2	10274625	16-40
MBK	Evolis	50	2	10274645	15-41
MBK	Fizz	50	2	10274645	15-41
MBK	Flipper	50	2	10274661	13-44
MBK	Forte	50	2	10274645	15-41
MBK	Hot Champ	50	2	10274670	17-40
MBK	Mach G 50	50	2	10274661	13-44
MBK	Mach G 50 LC	50	2	10274661	13-44
MBK	Nitro *50	50	2	10274661	13-44
MBK	Ovetto *50	50	2	10274661	13-44
MBK	Rocket	50	2	10274625	16-40
MBK	Rocket 50 euro 2	50	2	10274625	16-40
MBK	Skyliner 250	250	4	10274662	17-37
MBK	Sorriso *50 2T <-1995	50	2	10274620	17-40
MBK	Sorriso *50 2T 1996->	50	2	10274670	17-40
MBK	Stunt *50 2T euro 0-1	50	2	10274625	16-40
MBK	Stunt *50 2T euro 2	50	2	10274625	16-40
MBK	Target *50 2T	50	2	10274665	15-41
P.G.O.	Big Max *50 2T	50	2	10274623	13-44
P.G.O.	Comet *50 2T	50	2	10274680	16-32
P.G.O.	Star *50 2T	50	2	10274615	16-32
P.G.O.	Star II *50 2T	50	2	10274680	16-32
PEUGEOT	Buxy - Buxy Rs *50 2T	50	2	10274671	13-35
PEUGEOT	Elyseo *50 2T	50	2	10274671	13-35
PEUGEOT	Jet Force C-Tech *50 2T	50	2	10274671	13-35
PEUGEOT	Jet Force TSDI *50 2T	50	2	10274671	13-35
PEUGEOT	Ludix Blaster *50 2T	50	2	10274671	13-35
PEUGEOT	Metal-X *50 2T	50	2	10274671	13-35
PEUGEOT	Metropolis - Sc	50	2	10274630	16-32
PEUGEOT	Rapido *50 2T	50	2	10274635	16-32
PEUGEOT	Speedake *50 2T	50	2	10274671	13-35
PEUGEOT	Speedfight *50 2T	50	2	10274671	13-35
PEUGEOT	Speedfight *50 2T LC	50	2	10274671	13-35
PEUGEOT	Speedfight 2 *50 LC 2004->	50	2	10274671	13-35
PEUGEOT	Squab *50 2T	50	2	10274671	13-35
PEUGEOT	St *50 2T	50	2	10274635	16-32
PEUGEOT	SV 250 4T	250	4	10274692	17-37
PEUGEOT	Sv Geo *50 2T	50	2	10274655	15-33
PEUGEOT	Trekker *50 2T	50	2	10274671	13-35
PEUGEOT	Vivacity *50 KAT 2T	50	2	10274671	13-35
PEUGEOT	X-Fight *50 2T	50	2	10274671	13-35
PEUGEOT	X-Fight *50 2T LC	50	2	10274671	13-35
PEUGEOT	X-Fight 2 *50 LC 2004->	50	2	10274671	13-35
PEUGEOT	Zenith *50 2T	50	2	10274655	15-33
PIAGGIO	Diesis *50 2T	50	2	10274652	14-39
PIAGGIO	Free *50 2T	50	2	10274621 cal. 17,67 10274611 cal. 18,00	14-39
PIAGGIO	Hexagon 125 2T	125	2	10274622	15-41
PIAGGIO	Hexagon 150 2T	150	2	10274622	15-41
PIAGGIO	Hexagon LX 125 2T	125	2	10274672	15-41
PIAGGIO	Hexagon LXT 180 2T	180	2	10274682	14-43
PIAGGIO	NRG *50 LC	50	2	10274621 cal. 17,67 10274611 cal. 18,00	14-39
PIAGGIO	NRG Extreme	50	2	10274652	14-39
PIAGGIO	NRG Extreme LC	50	2	10274652	14-39
PIAGGIO	NRG Mc2 LC <-1997	50	2	10274621 cal. 17,67 10274611 cal. 18,00	14-39





MARCA	MODELLO	CC	TEMPI	CODICE	Z
BRAND	MODEL	CC	STROKE	ITEM	Z
PIAGGIO	NRG Mc2 LC 1998->	50	2	10274652	14-39
PIAGGIO	NRG Mc3 DD LC	50	2	10274652	14-39
PIAGGIO	NRG Mc3 DT	50	2	10274652	14-39
PIAGGIO	NRG Mc3 PureJet LC	50	2	10274652	14-39
PIAGGIO	NRG Power DD LC	50	2	10274652	14-39
PIAGGIO	NRG Power DT LC	50	2	10274652	14-39
PIAGGIO	NRG Power PureJet	50	2	10274652	14-39
PIAGGIO	NTT LC	50	2	10274621 cal. 17,67 10274611 cal. 18,00	14-39
PIAGGIO	Quartz LC	50	2	10274675 cal. 18,00	16-37
PIAGGIO	Sfera *50	50	2	10274650	16-37
PIAGGIO	Sfera *50 Rst	50	2	10274681 cal. 17,67 10274641 cal. 18,00	15-38
PIAGGIO	Sfera *75	75	2	10274650	16-37
PIAGGIO	Skipper 125 2T	125	2	10274612	16-40
PIAGGIO	Skipper 150 2T	150	2	10274612	16-40
PIAGGIO	Skipper LX 125	125	2	10274672	15-41
PIAGGIO	Skipper LXT 150	150	2	10274672	15-41
PIAGGIO	Super Hexagon GTX 125 4T	125	4	10274654	16-42
PIAGGIO	Super Hexagon GTX 180 4T	180	4	10274654	16-42
PIAGGIO	Typhoon *50 2T 2007->2010	50	2	10274652	14-39
PIAGGIO	X8 200 4T	200	4	10274654	16-42
PIAGGIO	X9 200 4T	200	4	10274654	16-42
PIAGGIO	X9 250 4T	250	4	10274692	16-38
PIAGGIO	Zip *50 2T	50	2	10274650	16-37
PIAGGIO	Zip *50 2T / 2000	50	2	10274653	-
PIAGGIO	Zip 125 4T (Leader Engine)	125	4	10274654	16-42
PIAGGIO	Zip Fast Rider	50	2	10274691 cal. 17,67 10274675 cal. 18,00	16-37
PIAGGIO	Zip SP LC ->2000	50	2	10274691 cal. 17,67	16-37
PIAGGIO	Zip SP LC 2001->	50	2	10274653	-
RIZZATO	Vamos	50	2	10274660	15-34
SUZUKI	Address Ah 50 2T	50	2	10274660	15-34
SUZUKI	AP *50 2T	50	2	10274660	15-34
SUZUKI	Estilete - UF 50 2T	50	2	10274633	15-40
SUZUKI	Katana *50 - 1999->	50	2	10274633	15-40
SUZUKI	Katana *50 <-1998)	50	2	10274633	15-40
SUZUKI	Katana *50 LC <-1998	50	2	10274633	15-40
SUZUKI	Katana *50 LC 1999->	50	2	10274633	15-40
SUZUKI	Sepia *50 2T	50	2	10274660	15-34
SUZUKI	Sepia *50 ZZ 2T	50	2	10274651	14-34
SUZUKI	Zillion *50 2T	50	2	10274633	15-40
YAMAHA	Aerox *50 euro 0-1	50	2	10274661	13-44
YAMAHA	Aerox *50 euro 2	50	2	10274661	13-44
YAMAHA	Axis *50 2T	50	2	10274670	17-40
YAMAHA	Beluga *50 2T	50	2	10274620	17-40
YAMAHA	Breeze *50 2T	50	2	10274645	15-41
YAMAHA	BW'S *50 euro 0-1	50	2	10274625	16-40
YAMAHA	BW'S *50 NG euro 0-1	50	2	10274625	16-40
YAMAHA	BW'S *50 NG euro 2	50	2	10274625	16-40
YAMAHA	BW'S *50 Original / Naked 2T euro 2 > 2010	50	2	10274625	16-40
YAMAHA	CRZ *50 2T	50	2	10274665	15-41
YAMAHA	CT *50 2T	50	2	10274620	17-40
YAMAHA	Jog *50	50	2	10274670	17-40
YAMAHA	Jog *50 ER	50	2	10274670	17-40
YAMAHA	Jog *50 R	50	2	10274661	13-44
YAMAHA	Jog *50 RR	50	2	10274661	13-44
YAMAHA	Jog *50 Z	50	2	10274670	17-40
YAMAHA	Majesty 250 4T	250	4	10274662	17-37
YAMAHA	Neo's *50 2T	50	2	10274661	13-44
YAMAHA	Slider *50 2T	50	2	10274625	16-40
YAMAHA	Spy *50 2T	50	2	10274625	16-40
YAMAHA	Vino *50 2T	50	2	10274670	17-40
YAMAHA	Why *50 2T	50	2	10274661	13-44
YAMAHA	Zest *50 2T	50	2	10274645	15-41
YAMAHA	Zuma *50 2T	50	2	10274625	16-40

Spring Slider

Esclusivo dispositivo, coperto da brevetto internazionale, costituito da un cuscinetto assiale ultrapiatto abbinato ad una specifica molla di contrasto: isolando la molla di contrasto dalla torsione delle pulegge condotte, allunga la vita della molla migliorando notevolmente prestazioni ed affidabilità.

This exclusive item has a international patent. It is made up of an ultraflat axial bearing combined with a particular return spring: isolation of the return spring from the torsion of the driven pulleys lengthens the working life of the spring, thus notably improving performance and reliability.

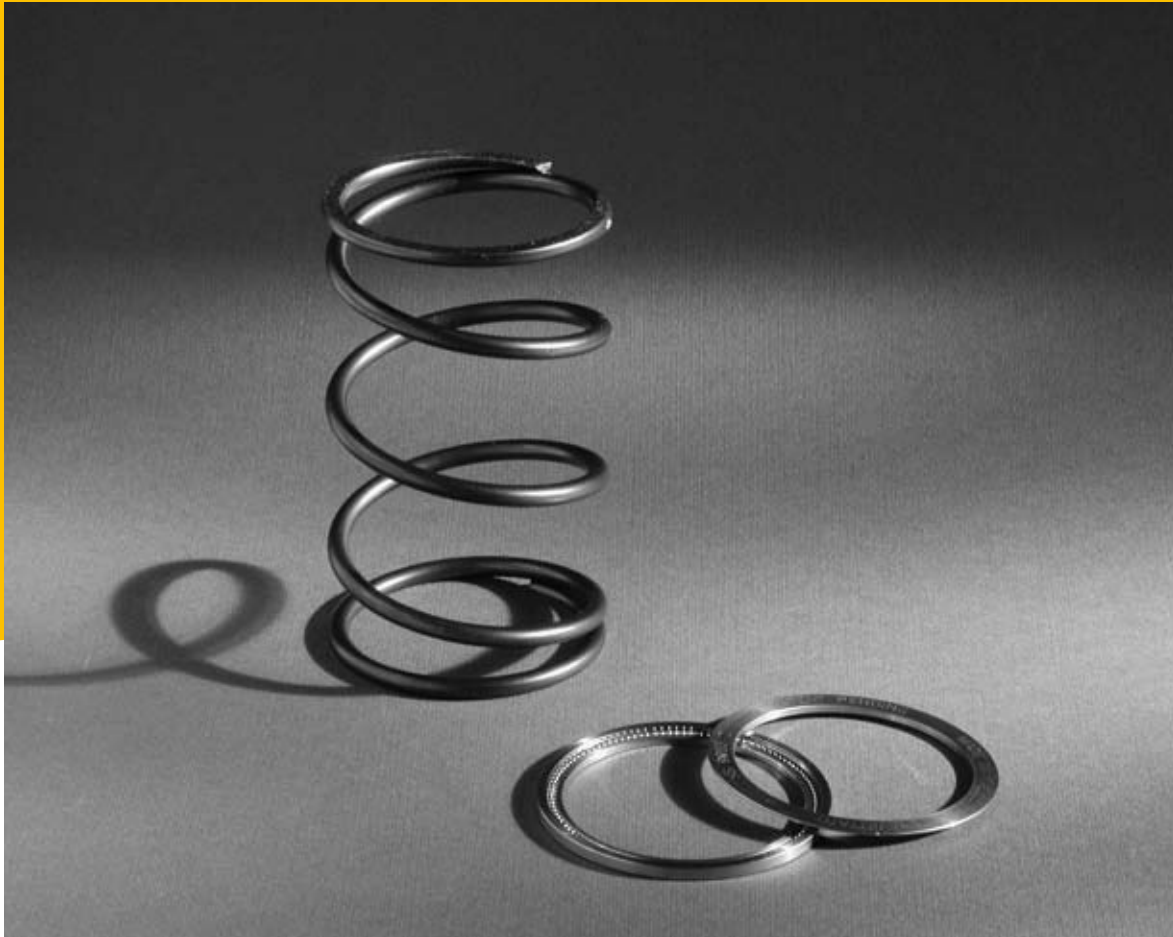

MARCA	MODELLO	CC	TEMPI	SPRING SLIDER	MOLLE RINFORZATE	MOLLE RACING
BRAND	MODEL	CC	STROKE	SPRING SLIDER	REINFORCED SPRINGS	RACING SPRINGS
APRILIA	Amico *50	50	2	10412024	10322018	10322010
APRILIA	Area 51	50	2	10412024	10322018	10322010
APRILIA	Atlantic - Arrecife 125	125	4	10412085	10322029	-
APRILIA	Atlantic - Arrecife 250	250	4	10412085	10322029	-
APRILIA	Atlantic 200	200	4	10412085	10322029	-
APRILIA	Atlantic 500 / 6 rulli	500	4	10412092	-	-
APRILIA	Atlantic Sprint - Arrecife 400	400	4	10412092	-	-
APRILIA	Atlantic Sprint - Arrecife 500	500	4	10412092	-	-
APRILIA	Gulliver *50	50	2	10412024	10322018	10322010
APRILIA	Gulliver *50 LC	50	2	10412024	10322018	10322010
APRILIA	Habana *50	50	2	10412024	10322018	10322010
APRILIA	Habana 125	125	4	10412081	-	-
APRILIA	Leonardo 125	125	4	10412021	10322025	-
APRILIA	Leonardo 150	150	4	10412021	10322025	-
APRILIA	Leonardo 150 ST	150	4	10412021	10322025	-
APRILIA	Leonardo 250	250	4	10412023	10322020	-
APRILIA	Leonardo 300	300	4	10412023	10322020	-
APRILIA	Mojito *50	50	2	10412024	10322018	10322010
APRILIA	Mojito *50 Custom	50	2	10412077	10322006	10322011
APRILIA	Mojito 125	125	4	10412081	-	-
APRILIA	Mojito 125 RY (Leader)	125	4	10412085	10322029	-
APRILIA	Rally *50	50	2	10412024	10322018	10322010
APRILIA	Rally *50 LC	50	2	10412024	10322018	10322010
APRILIA	Scarabeo *50 2T	50	2	10412024	10322018	10322010

MARCA	MODELLO	CC	TEMPI	SPRING SLIDER	MOLLE RINFORZATE	MOLLE RACING
BRAND	MODEL	CC	STROKE	SPRING SLIDER	REINFORCED SPRINGS	RACING SPRINGS
APRILIA	Scarabeo *50 2T Street Carburatore	50	2	10412077	10322006	10322011
APRILIA	Scarabeo *50 4T	50	4	10412077	10322006	10322011
APRILIA	Scarabeo *50 4T Street	50	4	10412077	-	-
APRILIA	Scarabeo 100 2T	100	2	10412027	10322028	-
APRILIA	Scarabeo 100 4T	100	4	10412077	10322006	10322011
APRILIA	Scarabeo 125	125	4	10412021	10322025	-
APRILIA	Scarabeo 125	125	4	10412085	10322029	-
APRILIA	Scarabeo 150	150	4	10412021	10322025	-
APRILIA	Scarabeo 250	250	4	10412085	10322029	-
APRILIA	Scarabeo 500 / 6 rulli	500	4	10412092	-	-
APRILIA	Scarabeo Light 250 i.e. (dal 2007)	250	4	10412085	10322029	-
APRILIA	Scarabeo Light 400 i.e.	400	4	10412092	-	-
APRILIA	Scarabeo Light 500 i.e.	500	4	10412092	-	-
APRILIA	Sonic *50	50	2	10412024	10322018	10322010
APRILIA	Sonic *50 LC	50	2	10412024	10322018	10322010
APRILIA	Sportcity 125	125	4	10412085	10322029	-
APRILIA	Sportcity 200	200	4	10412085	10322029	-
APRILIA	Sportcity 250 i.e. euro 3	250	4	10412085	10322029	-
APRILIA	Sportcity Cube 300 i.e.	300	4	10412085	10322029	-
APRILIA	Sportcity One *50 4T	50	4	10412077	-	-
APRILIA	Sportcity One 125 4t	125	4	10412085	10322029	-
APRILIA	SR *50 <-1993	50	2	10412024	10322018	10322010
APRILIA	SR *50 1994->	50	2	10412024	10322018	10322010
APRILIA	SR *50 2004 / Piaggio Carburatore	50	2	10412077	10322006	10322011
APRILIA	SR *50 DiTech GP1 / Piaggio Iniezione	50	2	10412077	10322006	10322011
APRILIA	SR *50 Netscaper LC	50	2	10412024	10322018	10322010
APRILIA	SR *50 R / Piaggio Carburatore	50	2	10412077	10322006	10322011
APRILIA	SR *50 R Factory	50	2	10412077	10322006	10322011
APRILIA	SR *50 Racing LC	50	2	10412024	10322018	10322010
APRILIA	SR *50 Replica LC	50	2	10412024	10322018	10322010
APRILIA	SR *50 Stealth LC	50	2	10412024	10322018	10322010
APRILIA	SR *50 WWW	50	2	10412024	10322018	10322010
APRILIA	SR 125	125	2	10412082	10322023	-
APRILIA	SR 150	150	2	10412082	10322023	-
ATALA	Carosello *50	50	2	10412024	10322018	10322010
ATALA	Hacker *50	50	2	10412024	10322018	10322010
ATALA	Hacker *50 LC	50	2	10412024	10322018	10322010
BENELLI	491 Gt	50	2	10412024	10322018	10322010
BENELLI	491 Sport LC	50	2	10412024	10322018	10322010
BENELLI	Adiva 125	125	4	10412085	10322029	-
BENELLI	Adiva 150	150	4	10412085	10322029	-
BENELLI	Adiva AD 250	250	4	10412085	10322029	-
BENELLI	K2 *50	50	2	10412024	10322018	10322010
BENELLI	K2 *50 LC	50	2	10412024	10322018	10322010
BENELLI	K2 100	100	2	10412027	10322028	-
BENELLI	Naked *50	50	2	10412024	10322018	10322010
BENELLI	Pepe *50	50	2	10412024	10322018	10322010
BENELLI	Pepe LX *50 euro 2	50	2	10412024	10322018	10322010
BENELLI	QuattroNove X *50 euro 2	50	2	10412024	10322018	10322010
BENELLI	Velvet 125	125	4	10412025	10322024	-
BENELLI	Velvet 150	150	4	10412025	10322024	-
BENELLI	Velvet 250	250	4	10412023	10322020	-
BENELLI	Velvet 400	400	4	10412083	10322026	-
BENELLI	Velvet 400 Dusk	400	4	10412083	10322026	-
BETA	Ark *50	50	2	10412024	10322018	10322010
BETA	Ark *50 LC	50	2	10412024	10322018	10322010
BETA	Chrono	50	2	10412024	10322018	10322010
BETA	Eikon *50 LC	50	2	10412024	10322018	10322010
BETA	Eikon 125	125	4	10412079	10322510	-
BETA	Eikon 150	150	4	10412079	10322510	-
BETA	Quadra	50	2	10412024	10322018	10322010
BETA	Tempo	50	2	10412024	10322018	10322010
BSV	Ax	50	2	10412024	10322018	10322010
BSV	Dio Gp	50	2	10412077	10322006	10322011
BSV	Dio Sp	50	2	10412077	10322006	10322011
BSV	Dio Zx (al 1993)	50	2	10412077	10322006	10322011
BSV	Dio Zx (dal 1994)	50	2	10412077	10322006	10322011

MARCA	MODELLO	CC	TEMPI	SPRING SLIDER	MOLLE RINFORZATE	MOLLE RACING
BRAND	MODEL	CC	STROKE	SPRING SLIDER	REINFORCED SPRINGS	RACING SPRINGS
BSV	Gz	50	2	10412024	10322018	10322010
CAGIVA	City	50	2	10412077	10322006	10322011
CPI	Aragon GP - Hussar - Oliver - Popcorn 2003 >	50	2	10412024	10322018	10322010
CPI	Hussar - Oliver - Popcorn < 2002	50	2	10412024	10322018	10322010
CPI	Aragon GP - Hussar - Oliver - Popcorn > 2003	50	2	10412024	10322018	10322010
DERBI	Boulevard 125	125	4	10412085	10322029	-
DERBI	Boulevard 150	150	4	10412085	10322029	-
DERBI	Boulevard 200	200	4	10412085	10322029	-
DERBI	Bullet *50	50	2	10412077	10322006	10322011
DERBI	GP1 *50 LC	50	2	10412077	10322006	10322011
DERBI	GP1 *50 OPEN	50	2	10412077	10322006	10322011
DERBI	GP1 *50 REVOLUTION	50	2	10412077	10322006	10322011
DERBI	GP1 125 LC	125	4	10412085	10322029	-
DERBI	GP1 250 LC	250	4	10412085	10322029	-
EXPLORER	Cracker *50 2003>	50	2	10412024	10322018	10322010
FANTIC	Big Wheel *50 2T	50	2	10412024	10322018	10322010
GARELLI	Gsp *50	50	2	10412024	10322018	10322010
GARELLI	Pony *50	50	2	10412024	10322018	10322010
GARELLI	Sr *50	50	2	10412024	10322018	10322010
GARELLI	Tiesse *50 R	50	2	10412024	10322018	10322010
GILERA	DNA *50 LC	50	2	10412077	10322006	10322011
GILERA	DNA 125	125	4	10412085	10322029	-
GILERA	DNA 180	180	4	10412085	10322029	-
GILERA	Easy Moving	50	2	10412077	10322006	10322011
GILERA	Fuoco 500 i.e.	500	4	10412092	-	-
GILERA	Ice *50 2T	50	2	10412077	10322006	10322011
GILERA	Nexus 125 euro 3	125	4	10412085	10322029	-
GILERA	Nexus 250 i.e. euro 3	250	4	10412085	10322029	-
GILERA	Nexus 500 / 6 rulli	500	4	10412092	-	-
GILERA	Nexus 500 / 8 rulli	500	4	10412092	-	-
GILERA	Runner *50 LC < 2005	50	2	10412077	10322006	10322011
GILERA	Runner *50 PureJet <-2005	50	2	10412077	10322006	10322011
GILERA	Runner *50 PureJet 2006->	50	2	10412077	10322006	10322011
GILERA	Runner *50 SP LC <-2005	50	2	10412077	10322006	10322011
GILERA	Runner *50 SP LC Carburatore 2006->	50	2	10412077	10322006	-
GILERA	Runner FX 125	125	2	10412082	10322023	-
GILERA	Runner FXR 180	180	2	10412082	10322023	-
GILERA	Runner VX 125 <-2005	125	4	10412085	10322029	-
GILERA	Runner VXR 180	180	4	10412085	10322029	-
GILERA	Runner VXR 200 - 2006->	200	4	10412085	10322029	-
GILERA	Runner VXR 200 <-2005	200	4	10412085	10322029	-
GILERA	Stalker	50	2	10412077	10322006	10322011
GILERA	Storm	50	2	10412077	10322006	10322011
GILERA	Typhoon	50	2	10412077	10322006	10322011
GILERA	Typhoon *50 X	50	2	10412077	10322006	10322011
GILERA	Typhoon 125	125	2	10412082	10322023	-
GILERA	Typhoon 125 X	125	2	10412082	10322023	-
HONDA	@125	125	4	10412088	-	-
HONDA	@150	150	4	10412088	-	-
HONDA	Bali *50	50	2	-	10322006	10322011
HONDA	CN 250	250	4	10412078	10322503	-
HONDA	Dio G	50	2	10412077	10322006	10322011
HONDA	Dio Sp	50	2	10412077	10322006	10322011
HONDA	Dio Sr	50	2	10412077	10322006	10322011
HONDA	Dio Zx <-1993	50	2	10412077	10322006	10322011
HONDA	Dio Zx 1994->	50	2	10412077	10322006	10322011
HONDA	Dylan 125	125	4	10412088	-	-
HONDA	Dylan 150	150	4	10412088	-	-
HONDA	Foresight 250	250	4	10412066 FG 10412075 GF	10322021 FG 10322022 GF	-
HONDA	Lead	50	2	10412077	10322006	10322011
HONDA	Pantheon 125	125	2	10412066	10322021	-
HONDA	Pantheon 125 4T i.e.	125	4	10412088	-	-
HONDA	Pantheon 150	150	2	10412066	10322021	-
HONDA	Pantheon 150 4T i.e.	150	4	10412088	-	-
HONDA	PS 125 i.e.	125	4	10412088	-	-
HONDA	PS 150 i.e.	150	4	10412088	-	-
HONDA	SFX *50	50	2	10412077	10322006	10322011

MARCA	MODELLO	CC	TEMPI	SPRING SLIDER	MOLLE RINFORZATE	MOLLE RACING
BRAND	MODEL	CC	STROKE	SPRING SLIDER	REINFORCED SPRINGS	RACING SPRINGS
HONDA	SH *50 - 1996->	50	2	-	10322006	10322011
HONDA	SH *50 <-1995	50	2	10412077	10322006	10322011
HONDA	SH 125	125	4	10412088	-	-
HONDA	SH 125 i.e.	125	4	10412088	-	-
HONDA	SH 150	150	4	10412088	-	-
HONDA	SH 150 i.e.	150	4	10412088	-	-
HONDA	Shadow *50	50	2	-	10322006	10322011
HONDA	Silver Wing 400	400	2	10412091	-	-
HONDA	Silver Wing 600	600	4	10412091	-	-
HONDA	Sky *50	50	2	-	10322006	10322011
HONDA	S-Wing 125 euro 3	125	4	10412088	-	-
HONDA	S-Wing 150 euro 3	150	4	10412088	-	-
HONDA	Vision	50	2	10412077	10322006	10322011
HONDA	Vision Met-In	50	2	10412077	10322006	10322011
HONDA	X8R X-S	50	2	-	10322006	10322011
HSC	Sc 01	50	2	10412077	10322006	10322011
HSC	Sc 01L Dio Zx	50	2	10412077	10322006	10322011
HUPPER	Montecarlo 30 2T	50	2	10412024	10322018	10322010
ITALJET	Bazooka	50	2	10412024	10322018	10322010
ITALJET	Dragster *50 LC	50	2	10412024	10322018	10322010
ITALJET	Dragster 125	125	2	10412082	10322023	-
ITALJET	Dragster 180	180	2	10412082	10322023	-
ITALJET	Formula *50	50	2	-	10322018	10322010
ITALJET	Formula *50 LC	50	2	-	10322018	10322010
ITALJET	Jet Set *50	50	2	10412077	10322006	10322011
ITALJET	Jet-Set 125 (Leader Engine)	125	4	10412085	10322029	-
ITALJET	Jet-Set 150 (Leader Engine)	150	4	10412085	10322029	-
ITALJET	Jupiter 125	125	4	10412025	10322024	-
ITALJET	Jupiter 150	150	4	10412025	10322024	-
ITALJET	Jupiter 250	250	4	10412023	10322020	-
ITALJET	Millennium 100	100	2	10412027	10322028	-
ITALJET	Millennium 125	125	4	10412025	10322024	-
ITALJET	Millennium 150	150	4	10412025	10322024	-
ITALJET	Pista	50	2	10412024	10322018	10322010
ITALJET	Pista 2	50	2	10412024	10322018	10322010
ITALJET	Reporter	50	2	10412024	10322018	10322010
ITALJET	Scoop	50	2	10412024	10322018	10322010
ITALJET	Torpedo *50 2T	50	2	10412024	10322018	10322010
ITALJET	Torpedo *50 2T New	50	2	10412077	10322006	10322011
ITALJET	Torpedo *50 4T	50	4	10412077	10322006	10322011
ITALJET	Torpedo 125	125	4	10412081	-	-
ITALJET	Torpedo 125 (Leader Engine)	125	4	10412085	10322029	-
ITALJET	Torpedo 150 (Leader Engine)	150	4	10412085	10322029	-
ITALJET	Velocifero	50	2	10412024	10322018	10322010
ITALJET	Yankee	50	2	10412024	10322018	10322010
KEEWAY	F-ACT	50	2	10412024	10322018	10322010
KEEWAY	Goccia	50	2	10412024	10322018	10322010
KEEWAY	Hurricane	50	2	10412024	10322018	10322010
KEEWAY	Matrix	50	2	10412024	10322018	10322010
KEEWAY	Pixel	50	2	10412024	10322018	10322010
KEEWAY	RY8	50	2	10412024	10322018	10322010
KYMCO	Agility 125 euro 3	125	4	10412089	-	-
KYMCO	B&W 125	125	4	10412079	10322510	-
KYMCO	B&W 150	150	4	10412079	10322510	-
KYMCO	B&W 250	250	4	10412066	10322021	-
KYMCO	CX	50	2	10412077	10322006	10322011
KYMCO	Dink 125	125	4	10412079	10322510	-
KYMCO	Dink 150	150	4	10412079	10322510	-
KYMCO	Dink 200	200	4	10412079	10322510	-
KYMCO	Dink DD 200 i.e.	200	4	10412079	10322510	-
KYMCO	Dj X	50	2	10412077	10322006	10322011
KYMCO	Dj Y	50	2	10412077	10322006	10322011
KYMCO	Grand Dink 125	125	4	10412079	10322510	-
KYMCO	Grand Dink 150	150	4	10412079	10322510	-
KYMCO	Grand Dink 250	250	4	10412066	10322021	-
KYMCO	Heroism	50	2	10412077	10322006	10322011
KYMCO	Movie 125 4T	125	4	10412089	-	-
KYMCO	Movie 150	150	4	10412089	-	-

MARCA	MODELLO	CC	TEMPI	SPRING SLIDER	MOLLE RINFORZATE	MOLLE RACING
BRAND	MODEL	CC	STROKE	SPRING SLIDER	REINFORCED SPRINGS	RACING SPRINGS
KYMCO	People *50	50	2	10412077	-	-
KYMCO	People 125	125	4	10412089	-	-
KYMCO	People 150	150	4	10412089	-	-
KYMCO	People 250	250	4	10412066	10322021	-
KYMCO	People S *50 2T	50	2	10412077	-	-
KYMCO	People S 125	125	4	10412089	-	-
KYMCO	People S 200	200	4	10412089	-	-
KYMCO	People S 250	250	4	10412066	10322021	-
KYMCO	Sniper *50 2T	50	2	10412077	10322006	10322011
KYMCO	Vivio 125	125	4	10412089	-	-
KYMCO	Vivio 150	150	4	10412089	-	-
KYMCO	Xciting 250	250	4	10412066	10322021	-
KYMCO	Yup 250	250	4	10412066	10322021	-
LEM	Flash *50 2T	50	2	10412024	10322018	10322010
LEM	Ghibli *50 2T	50	2	10412024	10322018	10322010
LEM	Tornado *50 2T	50	2	10412024	10322018	10322010
MALAGUTI	Centro *50 2T	50	2	10412024	10322018	10322010
MALAGUTI	Ciak *50	50	2	10412024	10322018	10322010
MALAGUTI	Ciak 100	100	2	10412026	-	-
MALAGUTI	Ciak Master *50 4T euro 2	50	4	10412077	-	-
MALAGUTI	Ciak Master 125	125	4	10412089	-	-
MALAGUTI	Ciak Master 150	150	4	10412089	-	-
MALAGUTI	Ciak Master 200	200	4	10412089	-	-
MALAGUTI	Crosser CR1	50	2	10412024	10322018	10322010
MALAGUTI	F10	50	2	10412024	10322018	10322010
MALAGUTI	F10 Wap	50	2	10412024	10322018	10322010
MALAGUTI	F12 Digit KAT 50 LC	50	2	10412024	10322018	10322010
MALAGUTI	F12 Digit KAT 50 LC euro 2	50	2	10412024	10322018	10322010
MALAGUTI	F12 Phantom Max 250	250	4	10412085	10322029	-
MALAGUTI	F12 Phantom *50	50	2	10412024	10322018	10322010
MALAGUTI	F12 Phantom *50 LC	50	2	10412024	10322018	10322010
MALAGUTI	F12 Phantom 100	100	2	10412026	-	-
MALAGUTI	F12 Phantom Max 125	125	4	10412025	10322024	-
MALAGUTI	F12 Phantom Max 200	200	4	10412085	10322029	-
MALAGUTI	F12 R AIR euro 2	50	2	10412024	10322018	10322010
MALAGUTI	F12 R LC euro 2	50	2	10412024	10322018	10322010
MALAGUTI	F15 Firefox LC	50	2	10412024	10322018	10322010
MALAGUTI	F18 Warrior 125	125	4	10412079	10322510	-
MALAGUTI	F18 Warrior 150	150	4	10412079	10322510	-
MALAGUTI	Madison 125	125	4	10412025	10322024	-
MALAGUTI	Madison 150	150	4	10412025	10322024	-
MALAGUTI	Madison 180	180	4	10412085	10322029	-
MALAGUTI	Madison 200	200	4	10412085	10322029	-
MALAGUTI	Madison 250 (Motore Yamaha)	250	4	10412023	10322020	-
MALAGUTI	Madison 3 - 125 (Motore Piaggio)	125	4	10412085	10322029	-
MALAGUTI	Madison 3 - 250 (Motore Piaggio)	250	4	10412085	10322029	-
MALAGUTI	Madison K400	400	4	10412083	10322026	-
MALAGUTI	Madison RS 250 (Motore Quasar)	250	4	10412085	10322029	-
MALAGUTI	Password 250	250	4	10412023	10322020	-
MALAGUTI	Password CK 250	250	4	10412023	10322020	-
MALAGUTI	Spidermax GT 500 / 6 rulli	500	4	10412092	-	-
MALAGUTI	Spidermax GT 500 / 8 rulli	500	4	10412092	-	-
MALAGUTI	Yesterday	50	2	10412024	10322018	10322010
MBK	Active	50	2	10412024	10322018	10322010
MBK	Booster *50 euro 0-1	50	2	10412024	10322018	10322010
MBK	Booster *50 Naked euro 2	50	2	10412024	10322018	10322010
MBK	Booster *50 NG euro 0-1	50	2	10412024	10322018	10322010
MBK	Booster *50 NG euro 2	50	2	10412024	10322018	10322010
MBK	Booster *50 Spirit euro 0-1	50	2	10412024	10322018	10322010
MBK	Booster 100 2T	100	2	10412027	10322028	-
MBK	Cityliner 125	125	4	10412025	10322024	-
MBK	Doodo 125	125	4	10412025	10322024	-
MBK	Doodo 150	150	4	10412025	10322024	-
MBK	Evolis	50	2	10412024	10322018	10322010
MBK	Fizz	50	2	10412024	10322018	10322010
MBK	Flipper	50	2	10412024	10322018	10322010
MBK	Forte	50	2	10412024	10322018	10322010
MBK	Hot Champ	50	2	10412024	10322018	10322010

MARCA	MODELLO	CC	TEMPI	SPRING SLIDER	MOLLE RINFORZATE	MOLLE RACING
BRAND	MODEL	CC	STROKE	SPRING SLIDER	REINFORCED SPRINGS	RACING SPRINGS
MBK	Kilibre 300	300	4	10412023	10322020	-
MBK	Mach G 50	50	2	10412024	10322018	10322010
MBK	Mach G 50 LC	50	2	10412024	10322018	10322010
MBK	Nitro *50	50	2	10412024	10322018	10322010
MBK	Nitro 100	100	2	10412027	10322028	-
MBK	Ovetto *50	50	2	10412024	10322018	10322010
MBK	Ovetto 100	100	2	10412027	10322028	-
MBK	Rocket	50	2	10412024	10322018	10322010
MBK	Rocket 50 euro 2	50	2	10412024	10322018	10322010
MBK	Skycruiser 125 i.e.	125	4	10412025	10322024	-
MBK	Skyliner 125	125	4	10412025	10322024	-
MBK	Skyliner 150	150	4	10412025	10322024	-
MBK	Skyliner 250	250	4	10412023	10322020	-
MBK	Sorriso *50 2T <-1995	50	2	10412024	10322018	10322010
MBK	Sorriso *50 2T 1996->	50	2	10412024	10322018	10322010
MBK	Stunt *50 2T euro 0-1	50	2	10412024	10322018	10322010
MBK	Stunt *50 2T euro 2	50	2	10412024	10322018	10322010
MBK	Target *50 2T	50	2	10412024	10322018	10322010
MBK	Thunder 125	125	4	10412025	10322024	-
MBK	Thunder 150	150	4	10412025	10322024	-
P.G.O.	Star *50 2T	50	2	10412077	10322006	10322011
PEUGEOT	Buxy - Buxy Rs *50 2T	50	2	10412077	10322006	10322011
PEUGEOT	Elyseo 100 KAT 2T	100	2	10412076	-	-
PEUGEOT	Geopolis 250 i.e	250	4	10412085	10322029	-
PEUGEOT	Geopolis 400	400	4	10412092	-	-
PEUGEOT	Looxor TSDI *50 2T	50	2	10412077	10322006	10322011
PEUGEOT	Metal-X *50 2T	50	2	10412077	10322006	10322011
PEUGEOT	Metropolis - Sc	50	2	10412077	10322006	10322011
PEUGEOT	Rapido *50 2T	50	2	10412077	10322006	10322011
PEUGEOT	Satelis 250 4T	250	4	10412085	10322029	-
PEUGEOT	Satelis 400 4T	400	4	10412092	-	-
PEUGEOT	Satelis 500 4T	500	4	10412092	-	-
PEUGEOT	Speedake *50 2T	50	2	10412077	10322006	10322011
PEUGEOT	Speedfight *50 2T	50	2	10412077	10322006	10322011
PEUGEOT	Speedfight *50 2T LC	50	2	10412077	10322006	10322011
PEUGEOT	Speedfight 100 KAT 2T	100	2	10412076	-	-
PEUGEOT	Squab *50 2T	50	2	10412077	10322006	10322011
PEUGEOT	St *50 2T	50	2	10412077	10322006	10322011
PEUGEOT	SV 250 4T	250	4	10412066 FG 10412075 GF	10322021 FG 10322022 GF	-
PEUGEOT	Sv Geo *50 2T	50	2	10412077	10322006	10322011
PEUGEOT	Trekker *50 2T	50	2	10412077	10322006	10322011
PEUGEOT	Trekker 100 KAT 2T	100	2	10412076	-	-
PEUGEOT	Vivacity *50 KAT 2T	50	2	10412077	10322006	10322011
PEUGEOT	Vivacity 100 KAT 2T	100	2	10412076	-	-
PEUGEOT	X-Fight *50 2T	50	2	10412077	10322006	10322011
PEUGEOT	X-Fight *50 2T LC	50	2	10412077	10322006	10322011
PEUGEOT	X-Fight 100 2T	100	2	10412076	-	-
PEUGEOT	Zenith *50 2T	50	2	10412077	10322006	10322011
PIAGGIO	Beverly 125 4T	125	4	10412085	10322029	-
PIAGGIO	Beverly 200 4T	200	4	10412085	10322029	-
PIAGGIO	Beverly 250 4T	250	4	10412085	10322029	-
PIAGGIO	Beverly 250 4T i.e.	250	4	10412085	10322029	-
PIAGGIO	Beverly 400 4T i.e.	400	4	10412092	-	-
PIAGGIO	Beverly 500 4T i.e. / 6 rulli	500	4	10412092	-	-
PIAGGIO	Beverly 500 4T i.e. / 8 rulli	500	4	10412092	-	-
PIAGGIO	Beverly Cruiser 250 i.e.	250	4	10412085	10322029	-
PIAGGIO	Beverly Cruiser 500 i.e. / 8 rulli	500	4	10412092	-	-
PIAGGIO	Carnaby 125 4T	125	4	10412085	10322029	-
PIAGGIO	Carnaby 200 4T	200	4	10412085	10322029	-
PIAGGIO	Diesis *50 2T	50	2	10412077	10322006	10322011
PIAGGIO	Fly *50 2T	50	2	10412077	10322006	10322011
PIAGGIO	Fly *50 4T	50	4	10412077	10322006	10322011
PIAGGIO	Fly 125 4T	125	4	10412085	10322029	-
PIAGGIO	Fly 150 4T	150	4	10412085	10322029	-
PIAGGIO	Free *50 2T	50	2	10412077	10322006	10322011
PIAGGIO	Free 100 4T	100	4	10412077	10322006	10322011
PIAGGIO	Hexagon 125 2T	125	2	10412082	10322023	-

MARCA	MODELLO	CC	TEMPI	SPRING SLIDER	MOLLE RINFORZATE	MOLLE RACING
BRAND	MODEL	CC	STROKE	SPRING SLIDER	REINFORCED SPRINGS	RACING SPRINGS
PIAGGIO	Hexagon 150 2T	150	2	10412082	10322023	-
PIAGGIO	Hexagon 250 4T	250	4	10412078	10322503	-
PIAGGIO	Hexagon LX 125 2T	125	2	10412082	10322023	-
PIAGGIO	Hexagon LX 4 125 4T	125	4	10412081	-	-
PIAGGIO	Hexagon LXT 180 2T	180	2	10412082	10322023	-
PIAGGIO	Liberty *50 2T	50	2	10412077	10322006	10322011
PIAGGIO	Liberty *50 4T	50	4	10412077	10322006	10322011
PIAGGIO	Liberty 100 4T	100	4	10412077	10322006	10322011
PIAGGIO	Liberty 125 4T euro 0-1 <-1999	125	4	10412081	-	-
PIAGGIO	Liberty 125 4T euro 1-2 (Leader Engine)	125	4	10412085	10322029	-
PIAGGIO	Liberty 150 4T (Leader Engine)	150	4	10412085	10322029	-
PIAGGIO	Liberty 150 4T euro 1-2 (Leader Engine)	150	4	10412085	10322029	-
PIAGGIO	Liberty 200 4T (Leader Engine)	200	4	10412085	10322029	-
PIAGGIO	Liberty S 50 4T	50	4	10412077	10322006	10322011
PIAGGIO	Liberty S 125 4T (Leader Engine)	125	4	10412085	10322029	-
PIAGGIO	Liberty S 200 4T (Leader Engine)	200	4	10412085	10322029	-
PIAGGIO	MP3 125 4T (Leader Engine)	125	4	10412085	10322029	-
PIAGGIO	MP3 250 4T i.e. (Quasar Engine)	250	4	10412085	10322029	-
PIAGGIO	MP3 400 4T i.e. (Master Engine)	400	4	10412092	-	-
PIAGGIO	NRG *50 LC	50	2	10412077	10322006	10322011
PIAGGIO	NRG Extreme	50	2	10412077	10322006	10322011
PIAGGIO	NRG Extreme LC	50	2	10412077	10322006	10322011
PIAGGIO	NRG Mc2 LC <-1997	50	2	10412077	10322006	10322011
PIAGGIO	NRG Mc2 LC 1998->	50	2	10412077	10322006	10322011
PIAGGIO	NRG Mc3 DD LC	50	2	10412077	10322006	10322011
PIAGGIO	NRG Mc3 DT	50	2	10412077	10322006	10322011
PIAGGIO	NRG Mc3 PureJet LC	50	2	10412077	10322006	10322011
PIAGGIO	NRG Power DD LC	50	2	10412077	10322006	10322011
PIAGGIO	NRG Power DT LC	50	2	10412077	10322006	10322011
PIAGGIO	NRG Power PureJet	50	2	10412077	10322006	10322011
PIAGGIO	NTT LC	50	2	10412077	10322006	10322011
PIAGGIO	Quartz LC	50	2	10412077	10322006	10322011
PIAGGIO	Sfera *50 Rst	50	2	10412077	10322006	10322011
PIAGGIO	Skipper 125 2T	125	2	10412082	10322023	-
PIAGGIO	Skipper 125 ST 4T (Leader Engine)	125	4	10412085	10322029	-
PIAGGIO	Skipper 150 2T	150	2	10412082	10322023	-
PIAGGIO	Skipper 150 ST 4T (Leader Engine)	150	4	10412085	10322029	-
PIAGGIO	Skipper LX 125	125	2	10412082	10322023	-
PIAGGIO	Skipper LXT 150	150	2	10412082	10322023	-
PIAGGIO	Super Hexagon GTX 125 4T	125	4	10412085	10322029	-
PIAGGIO	Super Hexagon GTX 180 4T	180	4	10412085	10322029	-
PIAGGIO	Super Hexagon GTX 250	250	4	10412078	10322503	-
PIAGGIO	Typhoon *50 2T 2007->2010	50	2	10412077	10322006	10322011
PIAGGIO	Typhoon *50 2T euro 2 - 2011->	50	2	10412077	10322006	10322011
PIAGGIO	X7 125 4T euro 3 (Leader Engine)	125	4	10412085	10322029	-
PIAGGIO	X7 250 4T i.e. euro 3 (Quasar Engine)	250	4	10412085	10322029	-
PIAGGIO	X8 125 4T euro 2-3 (Leader Engine)	125	4	10412085	10322029	-
PIAGGIO	X8 150	150	4	10412085	10322029	-
PIAGGIO	X8 200 4T	200	4	10412085	10322029	-
PIAGGIO	X8 250 4T euro 2	250	4	10412085	10322029	-
PIAGGIO	X8 250 4T i.e. euro 3	250	4	10412085	10322029	-
PIAGGIO	X8 400 4T i.e. euro 3	400	4	10412092	-	-
PIAGGIO	X9 125 4T	125	4	10412085	10322029	-
PIAGGIO	X9 180 4T Amalfi	180	4	10412085	10322029	-
PIAGGIO	X9 200 4T	200	4	10412085	10322029	-
PIAGGIO	X9 250 4T	250	4	10412066 FG 10412075 GF	10322021 FG 10322022 GF	-
PIAGGIO	X9 250 4T Evolution	250	4	10412085	10322029	-
PIAGGIO	X9 500 Evolution - Street / 6 rulli	500	4	10412092	-	-
PIAGGIO	X9 500 Evolution Street / 8 rulli	500	4	10412092	-	-
PIAGGIO	XEvo 125 4T euro 3	125	4	10412085	10322029	-
PIAGGIO	XEvo 250 4T i.e. euro 3	250	4	10412085	10322029	-
PIAGGIO	XEvo 400 4T i.e. euro 3	400	4	10412092	-	-
PIAGGIO	Zip *50 2T / 2000	50	2	10412077	10322006	10322011
PIAGGIO	Zip *50 4T	50	4	10412077	10322006	10322011
PIAGGIO	Zip 125 4T (Leader Engine)	125	4	10412085	10322029	-
PIAGGIO	Zip Fast Rider	50	2	10412077	10322006	10322011
PIAGGIO	Zip SP LC ->2000	50	2	10412077	10322006	10322011

MARCA	MODELLO	CC	TEMPI	SPRING SLIDER	MOLLE RINFORZATE	MOLLE RACING
BRAND	MODEL	CC	STROKE	SPRING SLIDER	REINFORCED SPRINGS	RACING SPRINGS
PIAGGIO	Zip SP LC 2001->	50	2	10412077	10322006	10322011
RIZZATO	Vamos	50	2	10412024	10322018	10322010
SUZUKI	Address Ah 50 2T	50	2	10412024	10322018	10322010
SUZUKI	AP *50 2T	50	2	10412024	10322018	10322010
SUZUKI	Burgman 125 K7 i.e.	125	4	10412064	-	-
SUZUKI	Burgman 200 4T i.e. euro 3	200	4	10412087	10321009	-
SUZUKI	Burgman 400 4T i.e. K 7	400	4	10412083	10320026	-
SUZUKI	Burgman AN 250 - 2001->	250	4	10412087	10321009	-
SUZUKI	Burgman AN 250 <-2000	250	4	10412062	10322506	-
SUZUKI	Burgman AN 400 4T - K3-K6	400	4	10412083	10322026	-
SUZUKI	Burgman UH 125 4T	125	4	10412064	-	-
SUZUKI	Burgman UH 150 4T	150	4	10412064	-	-
SUZUKI	Epicuro 125 4t	125	4	10412063	-	-
SUZUKI	Epicuro 150 4T	150	4	10412063	-	-
SUZUKI	Estilete - UF 50 2T	50	2	10412024	10322018	10322010
SUZUKI	Katana *50 - 1999->	50	2	10412024	10322018	10322010
SUZUKI	Katana *50 <-1998)	50	2	10412024	10322018	10322010
SUZUKI	Katana *50 LC <-1998	50	2	10412024	10322018	10322010
SUZUKI	Katana *50 LC 1999->	50	2	10412024	10322018	10322010
SUZUKI	Sepia *50 2T	50	2	10412024	10322018	10322010
SUZUKI	Sepia *50 ZZ 2T	50	2	10412024	10322018	10322010
SUZUKI	Sixteen 125 4T euro 3	125	4	10412064	-	-
SUZUKI	Sixteen 150 4T euro 3	150	4	10412064	-	-
SUZUKI	Zillion *50 2T	50	2	10412024	10322018	10322010
YAMAHA	Aerox *50 euro 0-1	50	2	10412024	10322018	10322010
YAMAHA	Aerox *50 euro 2	50	2	10412024	10322018	10322010
YAMAHA	Aerox 100 2T	100	2	10412027	10322028	-
YAMAHA	Axis *50 2T	50	2	10412024	10322018	10322010
YAMAHA	Beluga *50 2T	50	2	10412024	10322018	10322010
YAMAHA	Breeze *50 2T	50	2	10412024	10322018	10322010
YAMAHA	BW'S *50 euro 0-1	50	2	10412024	10322018	10322010
YAMAHA	BW'S *50 NG euro 0-1	50	2	10412024	10322018	10322010
YAMAHA	BW'S *50 NG euro 2	50	2	10412024	10322018	10322010
YAMAHA	BW'S *50 Original / Naked 2T euro 2 > 2010	50	2	10412024	10322018	10322010
YAMAHA	BW'S 100 2T	100	2	10412027	10322028	-
YAMAHA	CRZ *50 2T	50	2	10412024	10322018	10322010
YAMAHA	CT *50 2T	50	2	10412024	10322018	10322010
YAMAHA	Jog *50	50	2	10412024	10322018	10322010
YAMAHA	Jog *50 ER	50	2	10412024	10322018	10322010
YAMAHA	Jog *50 R	50	2	10412024	10322018	10322010
YAMAHA	Jog *50 RR	50	2	10412024	10322018	10322010
YAMAHA	Jog *50 Z	50	2	10412024	10322018	10322010
YAMAHA	Majesty 125 4T	125	4	10412025	10322024	-
YAMAHA	Majesty 150 4T	150	4	10412025	10322024	-
YAMAHA	Majesty 250 4T	250	4	10412023	10322020	-
YAMAHA	Majesty 400 4T <-2008	400	4	10412093	-	-
YAMAHA	Maxster 125 4T	125	4	10412025	10322024	-
YAMAHA	Maxster 150 4T	150	4	10412025	10322024	-
YAMAHA	Neo's *50 2T	50	2	10412024	10322018	10322010
YAMAHA	Neo's 100 2T	100	2	10412027	10322028	-
YAMAHA	Slider *50 2T	50	2	10412024	10322018	10322010
YAMAHA	Spy *50 2T	50	2	10412024	10322018	10322010
YAMAHA	Teo's 125 4T	125	4	10412025	10322024	-
YAMAHA	Teo's 150 4T	150	4	10412025	10322024	-
YAMAHA	TMax 500 <-2003	500	4	10412086	-	-
YAMAHA	TMax 500 i.e. <-2007	500	4	10412086	-	-
YAMAHA	TMax 500 i.e. 2008->2011	500	4	10412086	-	-
YAMAHA	Versity XC 300 4T	300	4	10412023	10322020	-
YAMAHA	Vino *50 2T	50	2	10412024	10322018	10322010
YAMAHA	Why *50 2T	50	2	10412024	10322018	10322010
YAMAHA	X-City 125 4T i.e.	125	4	10412025	10322024	-
YAMAHA	X-City 250 4T i.e.	250	4	10412023	10322020	-
YAMAHA	X-Max 125 4T i.e. <-2008	125	4	10412025	10322024	-
YAMAHA	X-Max 250 4T	250	4	10412023	10322020	-
YAMAHA	Zest *50 2T	50	2	10412024	10322018	10322010
YAMAHA	Zuma *50 2T	50	2	10412024	10322018	10322010

Molle di Contrasto Variatore Variator Return Springs

Molle di contrasto specifiche per scooter elaborati, indispensabili per una messa a punto ottimale della trasmissione automatica. Realizzate con acciai silicati, avvolgimento sinistrorso e disponibili con diversi carichi, a seconda delle esigenze.

Specific return springs for scooters are indispensable for optimal performance of the automatic transmission. These are made from silicate steels with counter-clockwise winding and are available with different loads to meet all requirements.



MARCA	MODELLO	CC	TEMPI	BIANCO +20%	GIALLO +40%	ROSSO +60%	NERO +80%	BLU +100%
BRAND	MODEL	CC	TEMPI	WHITE +20%	YELLOW +40%	RED +60%	BLACK +80%	BLUE +100%
APRILIA	Amico *50	50	2	10320017	10320018	10320019	-	-
APRILIA	Area 51	50	2	10320017	10320018	10320019	-	-
APRILIA	Atlantic - Arrecife 125	125	4	10320029	-	-	-	-
APRILIA	Atlantic - Arrecife 250	250	4	10320029	-	-	-	-
APRILIA	Atlantic 200	200	4	10320029	-	-	-	-
APRILIA	Gulliver *50	50	2	10320017	10320018	10320019	-	-
APRILIA	Gulliver *50 LC	50	2	10320017	10320018	10320019	-	-
APRILIA	Habana *50	50	2	10320017	10320018	10320019	-	-
APRILIA	Leonardo 125	125	4	-	10320025	-	-	-
APRILIA	Leonardo 150	150	4	-	10320025	-	-	-
APRILIA	Leonardo 150 ST	150	4	-	10320025	-	-	-
APRILIA	Leonardo 250	250	4	-	10320020	-	-	-
APRILIA	Leonardo 300	300	4	-	10320020	-	-	-
APRILIA	Mojito *50	50	2	10320017	10320018	10320019	-	-
APRILIA	Mojito *50 Custom	50	2	10320016	10320006	10320011	10320013	10320014
APRILIA	Mojito 125 RY (Leader)	125	4	10320029	-	-	-	-
APRILIA	Rally *50	50	2	10320017	10320018	10320019	-	-
APRILIA	Rally *50 LC	50	2	10320017	10320018	10320019	-	-
APRILIA	Scarabeo *50 2T	50	2	10320017	10320018	10320019	-	-
APRILIA	Scarabeo *50 2T Street Carburatore	50	2	10320016	10320006	10320011	10320013	10320014
APRILIA	Scarabeo *50 4T	50	4	10320016	10320006	10320011	10320013	10320014
APRILIA	Scarabeo *50 4T Street	50	4	10320016	10320006	10320011	10320013	10320014
APRILIA	Scarabeo *50 DiTech / Aprilia	50	2	10320017	10320018	10320019	-	-
APRILIA	Scarabeo 100 4T	100	4	-	-	10322011	-	-

MARCA	MODELLO	CC	TEMPI	BIANCO +20%	GIALLO +40%	ROSSO +60%	NERO +80%	BLU +100%
BRAND	MODEL	CC	TEMPI	WHITE +20%	YELLOW +40%	RED +60%	BLACK +80%	BLUE +100%
APRILIA	Scarabeo 125	125	4	-	10320025	-	-	-
APRILIA	Scarabeo 125	125	4	10320029	-	-	-	-
APRILIA	Scarabeo 150	150	4	-	10320025	-	-	-
APRILIA	Scarabeo 250	250	4	10320029	-	-	-	-
APRILIA	Scarabeo Light 250 i.e. (dal 2007)	250	4	10320029	-	-	-	-
APRILIA	Sonic *50	50	2	10320017	10320018	10320019	-	-
APRILIA	Sonic *50 LC	50	2	10320017	10320018	10320019	-	-
APRILIA	Sportcity 125	125	4	10320029	-	-	-	-
APRILIA	Sportcity 200	200	4	10320029	-	-	-	-
APRILIA	Sportcity 250 i.e. euro 3	250	4	10320029	-	-	-	-
APRILIA	Sportcity Cube 300 i.e.	300	4	10320029	-	-	-	-
APRILIA	Sportcity One *50 4T	50	4	10320016	10320006	10320011	10320013	10320014
APRILIA	Sportcity One 125 4t	125	4	10320029	-	-	-	-
APRILIA	SR *50 <-1993	50	2	10320017	10320018	10320019	-	-
APRILIA	SR *50 1994->	50	2	10320017	10320018	10320019	-	-
APRILIA	SR *50 DiTech / Aprilia	50	2	10320017	10320018	10320019	-	-
APRILIA	SR *50 Netscaper LC	50	2	10320017	10320018	10320019	-	-
APRILIA	SR *50 R / Piaggio Carburatore	50	2	10320016	10320006	10320011	10320013	10320014
APRILIA	SR *50 R Factory	50	2	10320016	10320006	10320011	10320013	10320014
APRILIA	SR *50 Racing LC	50	2	10320017	10320018	10320019	-	-
APRILIA	SR *50 Replica LC	50	2	10320017	10320018	10320019	-	-
APRILIA	SR *50 Replica LC 2000 / Aprilia	50	2	10320017	10320018	10320019	-	-
APRILIA	SR *50 Stealth LC	50	2	10320017	10320018	10320019	-	-
APRILIA	SR *50 WWW	50	2	10320017	10320018	10320019	-	-
APRILIA	SR 125	125	2	-	10320023	-	-	-
APRILIA	SR 150	150	2	-	10320023	-	-	-
ATALA	Carosello *50	50	2	10320017	10320018	10320019	-	-
ATALA	Hacker *50	50	2	10320017	10320018	10320019	-	-
ATALA	Hacker *50 LC	50	2	10320017	10320018	10320019	-	-
BENELLI	491 Gt	50	2	10320017	10320018	10320019	-	-
BENELLI	491 Sport LC	50	2	10320017	10320018	10320019	-	-
BENELLI	Adiva 125	125	4	10320029	-	-	-	-
BENELLI	Adiva 150	150	4	10320029	-	-	-	-
BENELLI	Adiva AD 250	250	4	10320029	-	-	-	-
BENELLI	K2 *50	50	2	10320017	10320018	10320019	-	-
BENELLI	K2 *50 LC	50	2	10320017	10320018	10320019	-	-
BENELLI	Naked *50	50	2	10320017	10320018	10320019	-	-
BENELLI	Pepe *50	50	2	10320017	10320018	10320019	-	-
BENELLI	Pepe LX *50 euro 2	50	2	10320017	10320018	10320019	-	-
BENELLI	QuattroNove X *50 euro 2	50	2	10320017	10320018	10320019	-	-
BENELLI	Velvet 125	125	4	-	10320024	-	-	-
BENELLI	Velvet 150	150	4	-	10320024	-	-	-
BENELLI	Velvet 250	250	4	-	10320020	-	-	-
BENELLI	Velvet 400	400	4	-	10320026	-	-	-
BENELLI	Velvet 400 Dusk	400	4	-	10320026	-	-	-
BETA	Ark *50	50	2	10320017	10320018	10320019	-	-
BETA	Ark *50 LC	50	2	10320017	10320018	10320019	-	-
BETA	Chrono	50	2	10320017	10320018	10320019	-	-
BETA	Eikon *50 LC	50	2	10320017	10320018	10320019	-	-
BETA	Quadra	50	2	10320017	10320018	10320019	-	-
BETA	Tempo	50	2	10320017	10320018	10320019	-	-
BSV	Ax	50	2	10320017	10320018	10320019	-	-
BSV	Dio Gp	50	2	10320016	10320006	10320011	10320013	10320014
BSV	Dio Sp	50	2	10320016	10320006	10320011	10320013	10320014
BSV	Dio Zx (al 1993)	50	2	10320016	10320006	10320011	10320013	10320014
BSV	Dio Zx (dal 1994)	50	2	10320016	10320006	10320011	10320013	10320014
BSV	Gz	50	2	10320017	10320018	10320019	-	-
CAGIVA	City	50	2	10320016	10320006	10320011	10320013	10320014
CAGIVA	Progress	50	2	10320017	10320018	10320019	-	-
CPI	Aragon GP - Hussar - Oliver - Popcorn 2003 >	50	2	10320017	10320018	10320019	-	-
CPI	Hussar - Oliver - Popcorn < 2002	50	2	10320017	10320018	10320019	-	-
CPI	Aragon GP - Hussar - Oliver - Popcorn > 2003	50	2	10320017	10320018	10320019	-	-
DERBI	Atlantis *50	50	2	10320017	10320018	10320019	-	-
DERBI	Atlantis *50 LC	50	2	10320017	10320018	10320019	-	-
DERBI	Boulevard 125	125	4	10320029	-	-	-	-
DERBI	Boulevard 150	150	4	10320029	-	-	-	-
DERBI	Boulevard 200	200	4	10320029	-	-	-	-
DERBI	GP1 *50 OPEN	50	2	10320016	10320006	10320011	10320013	10320014

MARCA	MODELLO	CC	TEMPI	BIANCO +20%	GIALLO +40%	ROSSO +60%	NERO +80%	BLU +100%
BRAND	MODEL	CC	TEMPI	WHITE +20%	YELLOW +40%	RED +60%	BLACK +80%	BLUE +100%
DERBI	GP1 *50 REVOLUTION	50	2	10320016	10320006	10320011	10320013	10320014
DERBI	GP1 125 LC	125	4	10320029	-	-	-	-
DERBI	GP1 250 LC	250	4	10320029	-	-	-	-
DERBI	Hunter	50	2	10320017	10320018	10320019	-	-
DERBI	Paddock *50 LC	50	2	10320017	10320018	10320019	-	-
DERBI	Predator *50	50	2	10320017	10320018	10320019	-	-
DERBI	Predator *50 LC	50	2	10320017	10320018	10320019	-	-
EXPLORER	Cracker *50 2003>	50	2	10320017	10320018	10320019	-	-
FANTIC	Big Wheel *50 2T	50	2	10320017	10320018	10320019	-	-
GARELLI	Gsp *50	50	2	10320017	10320018	10320019	-	-
GARELLI	Pony *50	50	2	10320017	10320018	10320019	-	-
GARELLI	Sr *50	50	2	10320017	10320018	10320019	-	-
GARELLI	Tiesse *50 R	50	2	10320017	10320018	10320019	-	-
GARELLI	VIP	50	4	10320016	10320006	10320011	10320013	10320014
GILERA	DNA *50 LC	50	2	10320016	10320006	10320011	10320013	10320014
GILERA	DNA 125	125	4	10320029	-	-	-	-
GILERA	DNA 180	180	4	10320029	-	-	-	-
GILERA	Easy Moving	50	2	10320016	10320006	10320011	10320013	10320014
GILERA	Nexus 125 euro 3	125	4	10320029	-	-	-	-
GILERA	Nexus 250 i.e. euro 3	250	4	10320029	-	-	-	-
GILERA	Runner *50 LC < 2005	50	2	10320016	-	10322011	-	-
GILERA	Runner *50 PureJet <-2005	50	2	-	-	10322011	-	-
GILERA	Runner *50 PureJet 2006->	50	2	-	-	10322011	-	-
GILERA	Runner *50 SP LC <-2005	50	2	10320016	-	10322011	-	-
GILERA	Runner *50 SP LC Carburatore 2006->	50	2	10320016	10320006	10320011	10320013	10320014
GILERA	Runner FX 125	125	2	-	10320023	-	-	-
GILERA	Runner FXR 180	180	2	-	10320023	-	-	-
GILERA	Runner VX 125 <-2005	125	4	10320029	-	-	-	-
GILERA	Runner VXR 180	180	4	10320029	-	-	-	-
GILERA	Runner VXR 200 - 2006->	200	4	10320029	-	-	-	-
GILERA	Runner VXR 200 <-2005	200	4	10320029	-	-	-	-
GILERA	Stalker	50	2	10320016	-	10322011	-	-
GILERA	Storm	50	2	10320016	10320006	10320011	10320013	10320014
GILERA	Typhoon	50	2	10320016	10320006	10320011	10320013	10320014
GILERA	Typhoon *50 X	50	2	10320016	-	10322011	-	-
GILERA	Typhoon 125	125	2	-	10320023	-	-	-
GILERA	Typhoon 125 X	125	2	-	10320023	-	-	-
HONDA	Bali *50	50	2	10320016	10320006	10320011	10320013	10320014
HONDA	Dio G	50	2	10320016	10320006	10320011	10320013	10320014
HONDA	Dio Sp	50	2	10320016	10320006	10320011	10320013	10320014
HONDA	Dio Sr	50	2	10320016	10320006	10320011	10320013	10320014
HONDA	Dio Zx <-1993	50	2	10320016	10320006	10320011	10320013	10320014
HONDA	Dio Zx 1994->	50	2	10320016	10320006	10320011	10320013	10320014
HONDA	Foresight 250	250	4	10320022	10320021	-	-	-
HONDA	Lead	50	2	10320016	10320006	10320011	10320013	10320014
HONDA	Pantheon 125	125	2	-	10320021	-	-	-
HONDA	Pantheon 150	150	2	-	10320021	-	-	-
HONDA	SFX *50	50	2	10320016	10320006	10320011	10320013	10320014
HONDA	SH *50 - 1996->	50	2	10320016	10320006	10320011	10320013	10320014
HONDA	SH *50 <-1995	50	2	10320016	10320006	10320011	10320013	10320014
HONDA	Shadow *50	50	2	10320016	10320006	10320011	10320013	10320014
HONDA	Sky *50	50	2	10320016	10320006	10320011	10320013	10320014
HONDA	Sxr	50	2	10320016	10320006	10320011	10320013	10320014
HONDA	Vision	50	2	10320016	10320006	10320011	10320013	10320014
HONDA	Vision Met-In	50	2	10320016	10320006	10320011	10320013	10320014
HONDA	X8R X-S	50	2	10320016	10320006	10320011	10320013	10320014
HSC	Sc 01	50	2	10320016	10320006	10320011	10320013	10320014
HSC	Sc 01L Dio Zx	50	2	10320016	10320006	10320011	10320013	10320014
HUPPER	Montecarlo 30 2T	50	2	10320017	10320018	10320019	-	-
ITALJET	Bazooka	50	2	10320017	10320018	10320019	-	-
ITALJET	Dragster *50 LC	50	2	10320017	10320018	10320019	-	-
ITALJET	Dragster 125	125	2	-	10320023	-	-	-
ITALJET	Dragster 180	180	2	-	10320023	-	-	-
ITALJET	Formula *50	50	2	10320017	10320018	10320019	-	-
ITALJET	Formula *50 LC	50	2	10320017	10320018	10320019	-	-
ITALJET	Jet-Set 125 (Leader Engine)	125	4	10320029	-	-	-	-
ITALJET	Jet-Set 150 (Leader Engine)	150	4	10320029	-	-	-	-
ITALJET	Jupiter 125	125	4	-	10320024	-	-	-

MARCA	MODELLO	CC	TEMPI	BIANCO +20%	GIALLO +40%	ROSSO +60%	NERO +80%	BLU +100%
BRAND	MODEL	CC	TEMPI	WHITE +20%	YELLOW +40%	RED +60%	BLACK +80%	BLUE +100%
ITALJET	Jupiter 150	150	4	-	10320024	-	-	-
ITALJET	Jupiter 250	250	4	-	10320020	-	-	-
ITALJET	Millennium 125	125	4	-	10320024	-	-	-
ITALJET	Millennium 150	150	4	-	10320024	-	-	-
ITALJET	Pista	50	2	10320017	10320018	10320019	-	-
ITALJET	Pista 2	50	2	10320017	10320018	10320019	-	-
ITALJET	Reporter	50	2	10320017	10320018	10320019	-	-
ITALJET	Scoop	50	2	10320017	10320018	10320019	-	-
ITALJET	Torpedo *50 2T	50	2	10320017	10320018	10320019	-	-
ITALJET	Torpedo 125 (Leader Engine)	125	4	10320029	-	-	-	-
ITALJET	Torpedo 150 (Leader Engine)	150	4	10320029	-	-	-	-
ITALJET	Velocifero	50	2	10320017	10320018	10320019	-	-
ITALJET	Yankee	50	2	10320017	10320018	10320019	-	-
KEEWAY	F-ACT	50	2	10320017	10320018	10320019	-	-
KEEWAY	Goccia	50	2	10320017	10320018	10320019	-	-
KEEWAY	Hurricane	50	2	10320017	10320018	10320019	-	-
KEEWAY	Matrix	50	2	10320017	10320018	10320019	-	-
KEEWAY	Pixel	50	2	10320017	10320018	10320019	-	-
KEEWAY	RY8	50	2	10320017	10320018	10320019	-	-
KYMCO	B&W 250	250	4	-	10320021	-	-	-
KYMCO	CX	50	2	10320016	10320006	10320011	10320013	10320014
KYMCO	Dink *50	50	2	10320016	10320006	10320011	10320013	10320014
KYMCO	Dink *50 LC	50	2	10320016	10320006	10320011	10320013	10320014
KYMCO	Dj X	50	2	10320016	10320006	10320011	10320013	10320014
KYMCO	Dj Y	50	2	10320016	10320006	10320011	10320013	10320014
KYMCO	Grand Dink 250	250	4	-	10320021	-	-	-
KYMCO	Heroism	50	2	10320016	10320006	10320011	10320013	10320014
KYMCO	K12	50	2	10320016	10320006	10320011	10320013	10320014
KYMCO	People *50	50	2	10320016	10320006	10320011	10320013	10320014
KYMCO	People *50 4T euro 2	50	4	10320016	10320006	10320011	10320013	10320014
KYMCO	People 250	250	4	-	10320021	-	-	-
KYMCO	People S *50 2T	50	2	10320016	10320006	10320011	10320013	10320014
KYMCO	People S *50 4T	50	4	10320016	10320006	10320011	10320013	10320014
KYMCO	People S 250	250	4	-	10320021	-	-	-
KYMCO	Sniper *50 2T	50	2	10320016	10320006	10320011	10320013	10320014
KYMCO	Super 8 - *50 4T euro 2	50	4	-	10320006	10320011	10320013	10320014
KYMCO	Super 9 - *50 LC	50	2	10320016	10320006	10320011	10320013	10320014
KYMCO	Top Boy - Cobra *50	50	2	10320016	10320006	10320011	10320013	10320014
KYMCO	Vitality *50	50	4	10320016	10320006	10320011	10320013	10320014
KYMCO	Xciting 250	250	4	-	10320021	-	-	-
KYMCO	Yup 250	250	4	-	10320021	-	-	-
LEM	Flash *50 2T	50	2	10320017	10320018	10320019	-	-
LEM	Ghibli *50 2T	50	2	10320017	10320018	10320019	-	-
LEM	Tornado *50 2T	50	2	10320017	10320018	10320019	-	-
MALAGUTI	Centro *50 2T	50	2	10320017	10320018	10320019	-	-
MALAGUTI	Ciak *50	50	2	10320017	10320018	10320019	-	-
MALAGUTI	Ciak 100	100	2	10320017	10320018	10320019	-	-
MALAGUTI	Ciak Master *50 4T euro 2	50	4	10320016	10320006	10320011	10320013	10320014
MALAGUTI	Crosser CR1	50	2	10320017	10320018	10320019	-	-
MALAGUTI	F10	50	2	10320017	10320018	10320019	-	-
MALAGUTI	F10 Wap	50	2	10320017	10320018	10320019	-	-
MALAGUTI	F12 Digit KAT 50 LC	50	2	10320017	10320018	10320019	-	-
MALAGUTI	F12 Digit KAT 50 LC euro 2	50	2	10320017	10320018	10320019	-	-
MALAGUTI	F12 Phantom Max 250	250	4	10320029	-	-	-	-
MALAGUTI	F12 Phantom *50	50	2	10320017	10320018	10320019	-	-
MALAGUTI	F12 Phantom *50 LC	50	2	10320017	10320018	10320019	-	-
MALAGUTI	F12 Phantom 100	100	2	10320017	10320018	10320019	-	-
MALAGUTI	F12 Phantom Max 125	125	4	-	10320024	-	-	-
MALAGUTI	F12 Phantom Max 200	200	4	10320029	-	-	-	-
MALAGUTI	F12 R AIR euro 2	50	2	10320017	10320018	10320019	-	-
MALAGUTI	F12 R LC euro 2	50	2	10320017	10320018	10320019	-	-
MALAGUTI	F15 Firefox LC	50	2	10320017	10320018	10320019	-	-
MALAGUTI	Madison 125	125	4	-	10320024	-	-	-
MALAGUTI	Madison 150	150	4	-	10320024	-	-	-
MALAGUTI	Madison 180	180	4	10320029	-	-	-	-
MALAGUTI	Madison 200	200	4	10320029	-	-	-	-
MALAGUTI	Madison 250 (Motore Yamaha)	250	4	-	10320020	-	-	-
MALAGUTI	Madison 3 - 125 (Motore Piaggio)	125	4	10320029	-	-	-	-

MARCA	MODELLO	CC	TEMPI	BIANCO +20%	GIALLO +40%	ROSSO +60%	NERO +80%	BLU +100%
BRAND	MODEL	CC	TEMPI	WHITE +20%	YELLOW +40%	RED +60%	BLACK +80%	BLUE +100%
MALAGUTI	Madison 3 - 250 (Motore Piaggio)	250	4	10320029	-	-	-	-
MALAGUTI	Madison K400	400	4	-	10320026	-	-	-
MALAGUTI	Madison RS 250 (Motore Quasar)	250	4	10320029	-	-	-	-
MALAGUTI	Password 250	250	4	-	10320020	-	-	-
MALAGUTI	Password CK 250	250	4	-	10320020	-	-	-
MALAGUTI	Yesterday	50	2	10320017	10320018	10320019	-	-
MBK	Active	50	2	10320017	10320018	10320019	-	-
MBK	Booster *50 euro 0-1	50	2	10320017	10320018	10320019	-	-
MBK	Booster *50 Naked euro 2	50	2	10320017	10320018	10320019	-	-
MBK	Booster *50 NG euro 0-1	50	2	10320017	10320018	10320019	-	-
MBK	Booster *50 NG euro 2	50	2	10320017	10320018	10320019	-	-
MBK	Booster *50 Spirit euro 0-1	50	2	10320017	10320018	10320019	-	-
MBK	Cityliner 125	125	4	-	10320024	-	-	-
MBK	Doodo 125	125	4	-	10320024	-	-	-
MBK	Doodo 150	150	4	-	10320024	-	-	-
MBK	Evolis	50	2	10320017	10320018	10320019	-	-
MBK	Fizz	50	2	10320017	10320018	10320019	-	-
MBK	Flipper	50	2	10320017	10320018	10320019	-	-
MBK	Forte	50	2	10320017	10320018	10320019	-	-
MBK	Hot Champ	50	2	10320017	10320018	10320019	-	-
MBK	Kilibre 300	300	4	-	10320020	-	-	-
MBK	Mach G 50	50	2	10320017	10320018	10320019	-	-
MBK	Mach G 50 LC	50	2	10320017	10320018	10320019	-	-
MBK	Nitro *50	50	2	10320017	10320018	10320019	-	-
MBK	Ovetto *50	50	2	10320017	10320018	10320019	-	-
MBK	Rocket	50	2	10320017	10320018	10320019	-	-
MBK	Rocket 50 euro 2	50	2	10320017	10320018	10320019	-	-
MBK	Skycruiser 125 i.e.	125	4	-	10320024	-	-	-
MBK	Skyliner 125	125	4	-	10320024	-	-	-
MBK	Skyliner 150	150	4	-	10320024	-	-	-
MBK	Skyliner 250	250	4	-	10320020	-	-	-
MBK	Sorriso *50 2T <-1995	50	2	10320017	10320018	10320019	-	-
MBK	Sorriso *50 2T 1996->	50	2	10320017	10320018	10320019	-	-
MBK	Stunt *50 2T euro 0-1	50	2	10320017	10320018	10320019	-	-
MBK	Stunt *50 2T euro 2	50	2	10320017	10320018	10320019	-	-
MBK	Target *50 2T	50	2	10320017	10320018	10320019	-	-
MBK	Thunder 125	125	4	-	10320024	-	-	-
MBK	Thunder 150	150	4	-	10320024	-	-	-
P.G.O.	Big Max *50 2T	50	2	10320016	10320006	10320011	10320013	10320014
P.G.O.	Star *50 2T	50	2	10320016	10320006	10320011	10320013	10320014
PEUGEOT	Buxy - Buxy Rs *50 2T	50	2	-	10320006	10320011	10320013	10320014
PEUGEOT	Elyseo *50 2T	50	2	-	10320006	10320011	10320013	10320014
PEUGEOT	Geopolis 250 i.e	250	4	10320029	-	-	-	-
PEUGEOT	Jet Force C-Tech *50 2T	50	2	-	10320006	10320011	10320013	10320014
PEUGEOT	Jet Force TSDI *50 2T	50	2	-	10320006	10320011	10320013	10320014
PEUGEOT	Looxor *50 2T	50	2	-	10320006	10320011	10320013	10320014
PEUGEOT	Looxor TSDI *50 2T	50	2	-	10320006	10320011	10320013	10320014
PEUGEOT	Ludix *50 2T	50	2	-	10320006	10320011	10320013	10320014
PEUGEOT	Ludix Blaster *50 2T	50	2	-	10320006	10320011	10320013	10320014
PEUGEOT	Metal-X *50 2T	50	2	-	10320006	10320011	10320013	10320014
PEUGEOT	Metropolis - Sc	50	2	-	10320006	10320011	10320013	10320014
PEUGEOT	Rapido *50 2T	50	2	-	10320006	10320011	10320013	10320014
PEUGEOT	Satelis 250 4T	250	4	10320029	-	-	-	-
PEUGEOT	Speedake *50 2T	50	2	-	10320006	10320011	10320013	10320014
PEUGEOT	Speedfight *50 2T	50	2	-	10320006	10320011	10320013	10320014
PEUGEOT	Speedfight *50 2T LC	50	2	-	10320006	10320011	10320013	10320014
PEUGEOT	Speedfight 2 *50 LC 2004->	50	2	-	10320006	10320011	10320013	10320014
PEUGEOT	Squab *50 2T	50	2	-	10320006	10320011	10320013	10320014
PEUGEOT	St *50 2T	50	2	-	10320006	10320011	10320013	10320014
PEUGEOT	SV 250 4T	250	4	10320022	10320021	-	-	-
PEUGEOT	Sv Geo *50 2T	50	2	-	10320006	10320011	10320013	10320014
PEUGEOT	Trekker *50 2T	50	2	-	10320006	10320011	10320013	10320014
PEUGEOT	Vivacity *50 KAT 2T	50	2	-	10320006	10320011	10320013	10320014
PEUGEOT	X-Fight *50 2T	50	2	-	10320006	10320011	10320013	10320014
PEUGEOT	X-Fight *50 2T LC	50	2	-	10320006	10320011	10320013	10320014
PEUGEOT	X-Fight 2 *50 LC 2004->	50	2	-	10320006	10320011	10320013	10320014
PEUGEOT	Zenith *50 2T	50	2	-	10320006	10320011	10320013	10320014
PIAGGIO	Beverly 125 4T	125	4	10320029	-	-	-	-

MARCA	MODELLO	CC	TEMPI	BIANCO +20%	GIALLO +40%	ROSSO +60%	NERO +80%	BLU +100%
BRAND	MODEL	CC	TEMPI	WHITE +20%	YELLOW +40%	RED +60%	BLACK +80%	BLUE +100%
PIAGGIO	Beverly 200 4T	200	4	10320029	-	-	-	-
PIAGGIO	Beverly 250 4T	250	4	10320029	-	-	-	-
PIAGGIO	Beverly 250 4T i.e.	250	4	10320029	-	-	-	-
PIAGGIO	Beverly Cruiser 250 i.e.	250	4	10320029	-	-	-	-
PIAGGIO	Carnaby 125 4T	125	4	10320029	-	-	-	-
PIAGGIO	Carnaby 200 4T	200	4	10320029	-	-	-	-
PIAGGIO	Diesis *50 2T	50	2	10320016	10320006	10320011	10320013	10320014
PIAGGIO	Fly *50 2T	50	2	10320016	10320006	10320011	10320013	10320014
PIAGGIO	Fly *50 4T	50	4	10320016	10320006	10320011	10320013	10320014
PIAGGIO	Fly 125 4T	125	4	10320029	-	-	-	-
PIAGGIO	Fly 150 4T	150	4	10320029	-	-	-	-
PIAGGIO	Free *50 2T	50	2	10320016	10320006	10320011	10320013	10320014
PIAGGIO	Free 100 4T	100	4	-	-	10322011	-	-
PIAGGIO	Hexagon 125 2T	125	2	-	10320023	-	-	-
PIAGGIO	Hexagon 150 2T	150	2	-	10320023	-	-	-
PIAGGIO	Hexagon LX 125 2T	125	2	-	10320023	-	-	-
PIAGGIO	Hexagon LXT 180 2T	180	2	-	10320023	-	-	-
PIAGGIO	Liberty *50 2T	50	2	10320016	10320006	10320011	10320013	10320014
PIAGGIO	Liberty *50 4T	50	4	10320016	10320006	10320011	10320013	10320014
PIAGGIO	Liberty 100 4T	100	4	-	-	10322011	-	-
PIAGGIO	Liberty 125 4T euro 1-2 (Leader Engine)	125	4	10320029	-	-	-	-
PIAGGIO	Liberty 150 4T (Leader Engine)	150	4	10320029	-	-	-	-
PIAGGIO	Liberty 150 4T euro 1-2 (Leader Engine)	150	4	10320029	-	-	-	-
PIAGGIO	Liberty 200 4T (Leader Engine)	200	4	10320029	-	-	-	-
PIAGGIO	Liberty S 50 4T	50	4	10320016	10320006	10320011	10320013	10320014
PIAGGIO	Liberty S 125 4T (Leader Engine)	125	4	10320029	-	-	-	-
PIAGGIO	Liberty S 200 4T (Leader Engine)	200	4	10320029	-	-	-	-
PIAGGIO	MP3 125 4T (Leader Engine)	125	4	10320029	-	-	-	-
PIAGGIO	MP3 250 4T i.e. (Quasar Engine)	250	4	10320029	-	-	-	-
PIAGGIO	NRG *50 LC	50	2	10320016	10320006	10320011	10320013	10320014
PIAGGIO	NRG Extreme	50	2	10320016	10320006	10320011	10320013	10320014
PIAGGIO	NRG Extreme LC	50	2	10320016	10320006	10320011	10320013	10320014
PIAGGIO	NRG Mc2 LC <-1997	50	2	10320016	10320006	10320011	10320013	10320014
PIAGGIO	NRG Mc2 LC 1998->	50	2	10320016	10320006	10320011	10320013	10320014
PIAGGIO	NRG Mc3 DD LC	50	2	10320016	10320006	10320011	10320013	10320014
PIAGGIO	NRG Mc3 DT	50	2	10320016	10320006	10320011	10320013	10320014
PIAGGIO	NRG Mc3 PureJet LC	50	2	10320016	10320006	10320011	10320013	10320014
PIAGGIO	NRG Power DD LC	50	2	10320016	10320006	10320011	10320013	10320014
PIAGGIO	NRG Power DT LC	50	2	10320016	10320006	10320011	10320013	-
PIAGGIO	NRG Power PureJet	50	2	10320016	10320006	10320011	10320013	10320014
PIAGGIO	NTT LC	50	2	10320016	10320006	10320011	10320013	10320014
PIAGGIO	Quartz LC	50	2	10320016	10320006	10320011	10320013	10320014
PIAGGIO	Sfera *50 Rst	50	2	10320016	10320006	10320011	10320013	10320014
PIAGGIO	Skipper 125 2T	125	2	-	10320023	-	-	-
PIAGGIO	Skipper 125 ST 4T (Leader Engine)	125	4	10320029	-	-	-	-
PIAGGIO	Skipper 150 2T	150	2	-	10320023	-	-	-
PIAGGIO	Skipper 150 ST 4T (Leader Engine)	150	4	10320029	-	-	-	-
PIAGGIO	Skipper LX 125	125	2	-	10320023	-	-	-
PIAGGIO	Skipper LXT 150	150	2	-	10320023	-	-	-
PIAGGIO	Super Hexagon GTX 125 4T	125	4	10320029	-	-	-	-
PIAGGIO	Super Hexagon GTX 180 4T	180	4	10320029	-	-	-	-
PIAGGIO	Typhoon *50 2T 2007->2010	50	2	10320016	10320006	10320011	10320013	10320014
PIAGGIO	Typhoon *50 2T euro 2 - 2011->	50	2	10320016	10320006	10320011	10320013	-
PIAGGIO	X7 125 4T euro 3 (Leader Engine)	125	4	10320029	-	-	-	-
PIAGGIO	X7 250 4T i.e. euro 3 (Quasar Engine)	250	4	10320029	-	-	-	-
PIAGGIO	X8 125 4T euro 2-3 (Leader Engine)	125	4	10320029	-	-	-	-
PIAGGIO	X8 150	150	4	10320029	-	-	-	-
PIAGGIO	X8 200 4T	200	4	10320029	-	-	-	-
PIAGGIO	X8 250 4T euro 2	250	4	10320029	-	-	-	-
PIAGGIO	X8 250 4T i.e. euro 3	250	4	10320029	-	-	-	-
PIAGGIO	X9 125 4T	125	4	10320029	-	-	-	-
PIAGGIO	X9 180 4T Amalfi	180	4	10320029	-	-	-	-
PIAGGIO	X9 200 4T	200	4	10320029	-	-	-	-
PIAGGIO	X9 250 4T	250	4	10320022	10320021	-	-	-
PIAGGIO	X9 250 4T Evolution	250	4	10320029	-	-	-	-
PIAGGIO	XEvo 125 4T euro 3	125	4	10320029	-	-	-	-
PIAGGIO	XEvo 250 4T i.e. euro 3	250	4	10320029	-	-	-	-
PIAGGIO	Zip *50 2T	50	2	10320016	10320006	10320011	10320013	10320014

MARCA	MODELLO	CC	TEMPI	BIANCO +20%	GIALLO +40%	ROSSO +60%	NERO +80%	BLU +100%
BRAND	MODEL	CC	TEMPI	WHITE +20%	YELLOW +40%	RED +60%	BLACK +80%	BLUE +100%
PIAGGIO	Zip *50 2T / 2000	50	2	10320016	10320006	10320011	10320013	10320014
PIAGGIO	Zip *50 4T	50	4	10320016	10320006	10320011	10320013	10320014
PIAGGIO	Zip 125 4T (Leader Engine)	125	4	10320029	-	-	-	-
PIAGGIO	Zip Fast Rider	50	2	10320016	10320006	10320011	10320013	10320014
PIAGGIO	Zip SP LC ->2000	50	2	10320016	10320006	10320011	10320013	10320014
PIAGGIO	Zip SP LC 2001->	50	2	10320016	10320006	10320011	10320013	10320014
RIZZATO	Vamos	50	2	10320017	10320018	10320019	-	-
SUZUKI	Address Ah 50 2T	50	2	10320017	10320018	10320019	-	-
SUZUKI	AP *50 2T	50	2	10320017	10320018	10320019	-	-
SUZUKI	Burgman 400 4T i.e. K 7	400	4	-	10320026	-	-	-
SUZUKI	Burgman AN 400 4T - K3-K6	400	4	-	10320026	-	-	-
SUZUKI	Estilete - UF 50 2T	50	2	10320017	10320018	10320019	-	-
SUZUKI	Katana *50 - 1999->	50	2	10320017	10320018	10320019	-	-
SUZUKI	Katana *50 <-1998)	50	2	10320017	10320018	10320019	-	-
SUZUKI	Katana *50 LC <-1998	50	2	10320017	10320018	10320019	-	-
SUZUKI	Katana *50 LC 1999->	50	2	10320017	10320018	10320019	-	-
SUZUKI	Sepia *50 2T	50	2	10320017	10320018	10320019	-	-
SUZUKI	Sepia *50 ZZ 2T	50	2	10320017	10320018	10320019	-	-
SUZUKI	Zillion *50 2T	50	2	10320017	10320018	10320019	-	-
SYM	DD *50 2T	50	2	-	10320006	10320011	10320013	10320014
YAMAHA	Aerox *50 euro 0-1	50	2	10320017	10320018	10320019	-	-
YAMAHA	Aerox *50 euro 2	50	2	10320017	10320018	10320019	-	-
YAMAHA	Axis *50 2T	50	2	10320017	10320018	10320019	-	-
YAMAHA	Beluga *50 2T	50	2	10320017	10320018	10320019	-	-
YAMAHA	Breeze *50 2T	50	2	10320017	10320018	10320019	-	-
YAMAHA	BW'S *50 euro 0-1	50	2	10320017	10320018	10320019	-	-
YAMAHA	BW'S *50 NG euro 0-1	50	2	10320017	10320018	10320019	-	-
YAMAHA	BW'S *50 NG euro 2	50	2	10320017	10320018	10320019	?	?
YAMAHA	BW'S *50 Original / Naked 2T euro 2 > 2010	50	2	10320017	10320018	10320019	-	-
YAMAHA	CRZ *50 2T	50	2	10320017	10320018	10320019	-	-
YAMAHA	CT *50 2T	50	2	10320017	10320018	10320019	-	-
YAMAHA	Jog *50	50	2	10320017	10320018	10320019	-	-
YAMAHA	Jog *50 ER	50	2	10320017	10320018	10320019	-	-
YAMAHA	Jog *50 R	50	2	10320017	10320018	10320019	-	-
YAMAHA	Jog *50 RR	50	2	10320017	10320018	10320019	-	-
YAMAHA	Jog *50 Z	50	2	10320017	10320018	10320019	-	-
YAMAHA	Majesty 125 4T	125	4	-	10320024	-	-	-
YAMAHA	Majesty 150 4T	150	4	-	10320024	-	-	-
YAMAHA	Majesty 250 4T	250	4	-	10320020	-	-	-
YAMAHA	Maxster 125 4T	125	4	-	10320024	-	-	-
YAMAHA	Maxster 150 4T	150	4	-	10320024	-	-	-
YAMAHA	Neo's *50 2T	50	2	10320017	10320018	10320019	-	-
YAMAHA	Slider *50 2T	50	2	10320017	10320018	10320019	-	-
YAMAHA	Spy *50 2T	50	2	10320017	10320018	10320019	-	-
YAMAHA	Teo's 125 4T	125	4	-	10320024	-	-	-
YAMAHA	Teo's 150 4T	150	4	-	10320024	-	-	-
YAMAHA	Versity XC 300 4T	300	4	-	10320020	-	-	-
YAMAHA	Vino *50 2T	50	2	10320017	10320018	10320019	-	-
YAMAHA	Why *50 2T	50	2	10320017	10320018	10320019	-	-
YAMAHA	X-City 125 4T i.e.	125	4	-	10320024	-	-	-
YAMAHA	X-City 250 4T i.e.	250	4	-	10320020	-	-	-
YAMAHA	X-Max 125 4T i.e. <-2008	125	4	-	10320024	-	-	-
YAMAHA	X-Max 250 4T	250	4	-	10320020	-	-	-
YAMAHA	Zest *50 2T	50	2	10320017	10320018	10320019	-	-
YAMAHA	Zuma *50 2T	50	2	10320017	10320018	10320019	-	-

Kit Molle Frizione Rinforzate Powered Clutch Springs Kit

Molle frizione per scooter e maxi scooter realizzate in acciaio al silicio con diversi carichi in base al regime d'innesto. Tarature facilmente riconoscibili dalle varie colorazioni.

Clutch springs for scooters and maxi scooters made from silicon steel with differing loads depending on the coupling speed. The calibrations are colour-coded.

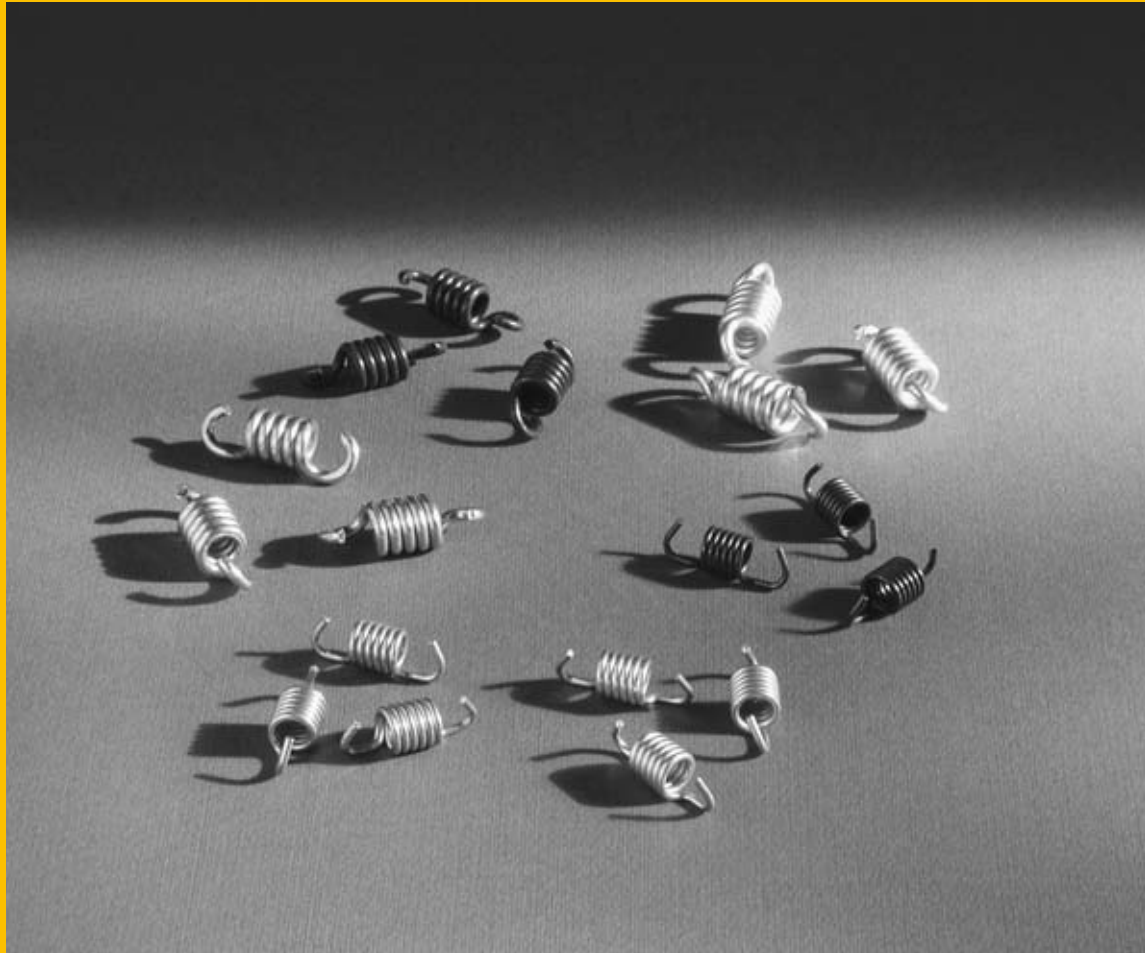

MARCA	MODELLO	CC	TEMPI	CODICE	MARCA	MODELLO	CC	TEMPI	CODICE
BRAND	MODEL	CC	STROKE	ITEM	BRAND	MODEL	CC	STROKE	ITEM
APRILIA	Amico *50	50	2	10371055 *	APRILIA	Scarabeo 125	125	4	10371057
APRILIA	Area 51	50	2	10371055	APRILIA	Scarabeo 150	150	4	10371057
APRILIA	Atlantic - Arrecife 125	125	4	10371057	APRILIA	Scarabeo 200	200	4	10371057
APRILIA	Atlantic - Arrecife 250	250	4	10371057	APRILIA	Scarabeo 250	250	4	10371057
APRILIA	Atlantic 200	200	4	10371057	APRILIA	Scarabeo 500 / 6 rulli	500	4	10371063
APRILIA	Atlantic 500 / 6 rulli	500	4	10371063	APRILIA	Scarabeo Light 250 i.e. (dal 2007)	250	4	10371057
APRILIA	Atlantic Sprint - Arrecife 400	400	4	10371063	APRILIA	Scarabeo Light 400 i.e.	400	4	10371063
APRILIA	Atlantic Sprint - Arrecife 500	500	4	10371063	APRILIA	Scarabeo Light 500 i.e.	500	4	10371063
APRILIA	Gulliver *50	50	2	10371055 *	APRILIA	Sonic *50	50	2	10371055
APRILIA	Gulliver *50 LC	50	2	10371055 *	APRILIA	Sonic *50 LC	50	2	10371055
APRILIA	Habana *50	50	2	10371053	APRILIA	Sportcity 125	125	4	10371057
APRILIA	Leonardo 125	125	4	10371057	APRILIA	Sportcity 200	200	4	10371057
APRILIA	Leonardo 150	150	4	10371057	APRILIA	Sportcity 250 i.e. euro 3	250	4	10371057
APRILIA	Leonardo 250	250	4	10371058	APRILIA	Sportcity Cube 300 i.e.	300	4	10371057
APRILIA	Mojito *50	50	2	10371053	APRILIA	Sportcity One *50 4T	50	4	10371052
APRILIA	Mojito *50 Custom	50	2	10371052	APRILIA	Sportcity One 125 4t	125	4	10371057
APRILIA	Mojito 125 RY (Leader)	125	4	10371057	APRILIA	SR *50 <-1993	50	2	10371050
APRILIA	Rally *50	50	2	10371055 *	APRILIA	SR *50 1994->	50	2	10371055 *
APRILIA	Rally *50 LC	50	2	10371055 *	APRILIA	SR *50 2004 / Piaggio Carburatore	50	2	10371052
APRILIA	Scarabeo *50 2T	50	2	10371055 *	APRILIA	SR *50 Netscaper LC	50	2	10371055
APRILIA	Scarabeo *50 2T Street Carburatore	50	2	10371052	APRILIA	SR *50 R / Piaggio Carburatore	50	2	10371052
APRILIA	Scarabeo 100 2T	100	2	10371051	APRILIA	SR *50 Racing LC	50	2	10371055
APRILIA	Scarabeo 125	125	4	10371057	APRILIA	SR *50 Replica LC	50	2	10371055 *

MARCA	MODELLO	CC	TEMPI	CODICE
BRAND	MODEL	CC	STROKE	ITEM
APRILIA	SR *50 Replica LC 2000 / Aprilia	50	2	10371052
APRILIA	SR *50 Stealth LC	50	2	10371055
APRILIA	SR *50 WWW	50	2	10371055
APRILIA	SR 125	125	2	10371056
APRILIA	SR 150	150	2	10371056
ATALA	Carosello *50	50	2	10371055 *
ATALA	Hacker *50	50	2	10371053
ATALA	Hacker *50 LC	50	2	10371053
BENELLI	491 Gt	50	2	10371055
BENELLI	491 Sport LC	50	2	10371055
BENELLI	Adiva 125	125	4	10371057
BENELLI	Adiva 150	150	4	10371057
BENELLI	Adiva AD 250	250	4	10371057
BENELLI	K2 *50	50	2	10371055
BENELLI	K2 *50 LC	50	2	10371055
BENELLI	K2 100	100	2	10371051
BENELLI	Pepe *50	50	2	10371055 *
BENELLI	Velvet 125	125	4	10371058
BENELLI	Velvet 150	150	4	10371057
BENELLI	Velvet 250	250	4	10371058
BETA	Ark *50	50	2	10371055 *
BETA	Ark *50 LC	50	2	10371055 *
BETA	Chrono	50	2	10371055 *
BETA	Eikon *50 LC	50	2	10371055
BETA	Eikon 125	125	4	10371057
BETA	Eikon 150	150	4	10371057
BETA	Quadra	50	2	10371050
BETA	Tempo	50	2	10371050
BSV	Ax	50	2	10371051
BSV	Dio Gp	50	2	10371052
BSV	Dio Sp	50	2	10371053
BSV	Dio Zx (al 1993)	50	2	10371052
BSV	Dio Zx (dal 1994)	50	2	10371052
BSV	Gz	50	2	10371051
CAGIVA	City	50	2	10371052
CAGIVA	Progress	50	2	10371051
CPI	Hussar - Oliver - Popcorn < 2002	50	2	10371050
DERBI	Atlantis *50	50	2	10371051
DERBI	Atlantis *50 LC	50	2	10371051
DERBI	Boulevard 125	125	4	10371057
DERBI	Boulevard 150	150	4	10371057
DERBI	Boulevard 200	200	4	10371057
DERBI	Bullet *50	50	2	10371052
DERBI	GP1 *50 LC	50	2	10371052
DERBI	GP1 *50 OPEN	50	2	10371052
DERBI	GP1 *50 REVOLUTION	50	2	10371052
DERBI	GP1 125 LC	125	4	10371057
DERBI	GP1 250 LC	250	4	10371057
DERBI	Hunter	50	2	10371051
DERBI	Paddock *50 LC	50	2	10371051
DERBI	Predator *50	50	2	10371051
DERBI	Predator *50 LC	50	2	10371051
FANTIC	Big Wheel *50 2T	50	2	10371050
GARELLI	Pony *50	50	2	10371050
GARELLI	Sr *50	50	2	10371050
GILERA	DNA *50 LC	50	2	10371052
GILERA	DNA 125	125	4	10371057
GILERA	DNA 180	180	4	10371057
GILERA	Easy Moving	50	2	10371052
GILERA	Fuoco 500 i.e.	500	4	10371063
GILERA	Ice *50 2T	50	2	10371052
GILERA	Nexus 125 euro 3	125	4	10371057
GILERA	Nexus 250 i.e. euro 3	250	4	10371057
GILERA	Nexus 500 / 6 rulli	500	4	10371063
GILERA	Nexus 500 / 8 rulli	500	4	10371063
GILERA	Runner *50 LC < 2005	50	2	10371052
GILERA	Runner *50 SP LC <-2005	50	2	10371052
GILERA	Runner *50 SP LC Carburatore 2006->	50	2	10371052
GILERA	Runner FX 125	125	2	10371056

MARCA	MODELLO	CC	TEMPI	CODICE
BRAND	MODEL	CC	STROKE	ITEM
GILERA	Runner FXR 180	180	2	10371056
GILERA	Runner VX 125 <-2005	125	4	10371057
GILERA	Runner VXR 180	180	4	10371057
GILERA	Runner VXR 200 - 2006->	200	4	10371057
GILERA	Runner VXR 200 <-2005	200	4	10371057
GILERA	Stalker	50	2	10371052
GILERA	Storm	50	2	10371052
GILERA	Typhoon	50	2	10371052
GILERA	Typhoon *50 X	50	2	10371052
GILERA	Typhoon 125	125	2	10371056
GILERA	Typhoon 125 X	125	2	10371056
HONDA	@125	125	4	10371062
HONDA	@150	150	4	10371062
HONDA	Bali *50	50	2	10371055 *
HONDA	CN 250	250	4	10371057
HONDA	Dio G	50	2	10371052
HONDA	Dio Sp	50	2	10371053
HONDA	Dio Sr	50	2	10371053
HONDA	Dio Zx <-1993	50	2	10371052
HONDA	Dio Zx 1994->	50	2	10371052
HONDA	Dylan 125	125	4	10371062
HONDA	Dylan 150	150	4	10371062
HONDA	Foresight 250	250	4	10371057
HONDA	Forza 250 - 2001->	250	4	10371057
HONDA	Forza X 250 - 2008->	250	4	10371057
HONDA	Forza X 250 <-2007	250	4	10371057
HONDA	Lead	50	2	10371053
HONDA	Pantheon 125	125	2	10371057
HONDA	Pantheon 125 4T i.e.	125	4	10371062
HONDA	Pantheon 150	150	2	10371057
HONDA	Pantheon 150 4T i.e.	150	4	10371062
HONDA	PS 125 i.e.	125	4	10371062
HONDA	PS 150 i.e.	150	4	10371062
HONDA	SFX *50	50	2	10371055 *
HONDA	SH *50 - 1996->	50	2	10371055 *
HONDA	SH *50 <-1995	50	2	10371053
HONDA	SH 125	125	4	10371062
HONDA	SH 125 i.e.	125	4	10371062
HONDA	SH 150	150	4	10371062
HONDA	SH 150 i.e.	150	4	10371062
HONDA	SH 300 i.e. <-2010	300	4	10371057
HONDA	Shadow *50	50	2	10371055 *
HONDA	Sky *50	50	2	10371055 *
HONDA	S-Wing 125 euro 3	125	4	10371062
HONDA	S-Wing 150 euro 3	150	4	10371062
HONDA	Sxr	50	2	10371055
HONDA	Vision	50	2	10371052
HONDA	Vision Met-In	50	2	10371052
HONDA	X8R X-S	50	2	10371055 *
HSC	Sc 01	50	2	10371053
HSC	Sc 01L Dio Zx	50	2	10371052
ITALJET	Bazooka	50	2	10371050
ITALJET	Dragster *50 LC	50	2	10371055
ITALJET	Dragster 125	125	2	10371056
ITALJET	Dragster 180	180	2	10371056
ITALJET	Formula *50	50	2	10371053
ITALJET	Formula *50 LC	50	2	10371053
ITALJET	Jet Set *50	50	2	10371052
ITALJET	Jet-Set 125 (Leader Engine)	125	4	10371057
ITALJET	Jet-Set 150 (Leader Engine)	150	4	10371057
ITALJET	Jupiter 125	125	4	10371058
ITALJET	Jupiter 150	150	4	10371057
ITALJET	Jupiter 250	250	4	10371058
ITALJET	Millennium 125	125	4	10371058
ITALJET	Millennium 150	150	4	10371057
ITALJET	Pista	50	2	10371050
ITALJET	Pista 2	50	2	10371050
ITALJET	Reporter	50	2	10371050
ITALJET	Scoop	50	2	10371050

MARCA	MODELLO	CC	TEMPI	CODICE	MARCA	MODELLO	CC	TEMPI	CODICE
BRAND	MODEL	CC	STROKE	ITEM	BRAND	MODEL	CC	STROKE	ITEM
ITALJET	Torpedo *50 2T	50	2	10371053	MBK	Booster *50 Naked euro 2	50	2	10371052
ITALJET	Torpedo *50 2T New	50	2	10371052	MBK	Booster *50 NG euro 0-1	50	2	10371055 *
ITALJET	Torpedo 125 (Leader Engine)	125	4	10371057	MBK	Booster *50 NG euro 2	50	2	10371052
ITALJET	Torpedo 150 (Leader Engine)	150	4	10371057	MBK	Booster *50 Spirit euro 0-1	50	2	10371055 *
ITALJET	Velocifero	50	2	10371053	MBK	Booster 100 2T	100	2	10371051
ITALJET	Yankee	50	2	10371050	MBK	Doodo 125	125	4	10371058
KEEWAY	F-ACT	50	2	10371053	MBK	Doodo 150	150	4	10371057
KEEWAY	Goccia	50	2	10371053	MBK	Evolis	50	2	10371051
KEEWAY	Hurricane	50	2	10371053	MBK	Fizz	50	2	10371051
KEEWAY	Matrix	50	2	10371053	MBK	Flipper	50	2	10371055
KEEWAY	Pixel	50	2	10371053	MBK	Forte	50	2	10371055 *
KEEWAY	RY8	50	2	10371053	MBK	Hot Champ	50	2	10371055 *
KYMCO	B&W 125	125	4	10371057	MBK	Kilibre 300	300	4	10371059
KYMCO	B&W 150	150	4	10371057	MBK	Mach G 50	50	2	10371055 *
KYMCO	Dink *50	50	2	10371055 *	MBK	Mach G 50 LC	50	2	10371055 *
KYMCO	Dink *50 LC	50	2	10371055	MBK	Nitro *50	50	2	10371055
KYMCO	Dink 125	125	4	10371057	MBK	Nitro 100	100	2	10371051
KYMCO	Dink 150	150	4	10371057	MBK	Ovetto *50	50	2	10371055
KYMCO	Dj X	50	2	10371052	MBK	Ovetto 100	100	2	10371051
KYMCO	Dj Y	50	2	10371052	MBK	Rocket	50	2	10371055 *
KYMCO	Grand Dink 125	125	4	10371057	MBK	Rocket 50 euro 2	50	2	10371052
KYMCO	Grand Dink 150	150	4	10371057	MBK	Skycruiser 125 i.e.	125	4	10371059
KYMCO	Heroism	50	2	10371055 *	MBK	Skyliner 125	125	4	10371058
KYMCO	K12	50	2	10371055 *	MBK	Skyliner 150	150	4	10371057
KYMCO	People *50	50	2	10371055 *	MBK	Skyliner 250	250	4	10371059
KYMCO	People 125	125	4	10371062	MBK	Sorriso *50 2T <-1995	50	2	10371050
KYMCO	People 150	150	4	10371062	MBK	Sorriso *50 2T 1996->	50	2	10371055 *
KYMCO	People S *50 2T	50	2	10371055	MBK	Stunt *50 2T euro 0-1	50	2	10371055
KYMCO	People S 125	125	4	10371062	MBK	Stunt *50 2T euro 2	50	2	10371052
KYMCO	People S 200	200	4	10371062	MBK	Target *50 2T	50	2	10371050
KYMCO	Sniper *50 2T	50	2	10371052	MBK	Thunder 125	125	4	10371058
KYMCO	Super 8 - *50 4T euro 2	50	4	10371055	MBK	Thunder 150	150	4	10371057
KYMCO	Super 9 - *50 LC	50	2	10371055	P.G.O.	Big Max *50 2T	50	2	10371051
KYMCO	Top Boy - Cobra *50	50	2	10371055 *	PEUGEOT	Buxy - Buxy Rs *50 2T	50	2	10371055 *
KYMCO	Vitality *50	50	4	10371055	PEUGEOT	Elyseo *50 2T	50	2	10371055
LEM	Flash *50 2T	50	2	10371050	PEUGEOT	Elyseo 100 KAT 2T	100	2	10371058
LEM	Ghibli *50 2T	50	2	10371050	PEUGEOT	Geopolis 125 i.e	125	4	10371057
LEM	Tornado *50 2T	50	2	10371050	PEUGEOT	Geopolis 250 i.e	250	4	10371057
MALAGUTI	Centro *50 2T	50	2	10371055 *	PEUGEOT	Geopolis 400	400	4	10371063
MALAGUTI	Ciak *50	50	2	10371055	PEUGEOT	Jet Force 125 4T	125	4	10371057
MALAGUTI	Ciak 100	100	2	10371053	PEUGEOT	Looxor 100 2T	100	2	10371058
MALAGUTI	Ciak Master 125	125	4	10371062	PEUGEOT	Metal-X *50 2T	50	2	10371055
MALAGUTI	Ciak Master 150	150	4	10371062	PEUGEOT	Metropolis - Sc	50	2	10371053
MALAGUTI	Ciak Master 200	200	4	10371062	PEUGEOT	Rapido *50 2T	50	2	10371052
MALAGUTI	Crosser CR1	50	2	10371053	PEUGEOT	Satellis 125 4T	125	4	10371057
MALAGUTI	F10	50	2	10371055 *	PEUGEOT	Satellis 125 Compressor 4T	125	4	10371059
MALAGUTI	F12 Digit KAT 50 LC	50	2	10371055 *	PEUGEOT	Satellis 250 4T	250	4	10371057
MALAGUTI	F12 Digit KAT 50 LC euro 2	50	2	10371055 *	PEUGEOT	Satellis 400 4T	400	4	10371063
MALAGUTI	F12 Phantom Max 250	250	4	10371057	PEUGEOT	Satellis 500 4T	500	4	10371063
MALAGUTI	F12 Phantom *50	50	2	10371055 *	PEUGEOT	Speedake *50 2T	50	2	10371052
MALAGUTI	F12 Phantom *50 LC	50	2	10371055 *	PEUGEOT	Speedfight *50 2T	50	2	10371055 *
MALAGUTI	F12 Phantom 100	100	2	10371053	PEUGEOT	Speedfight *50 2T LC	50	2	10371055 *
MALAGUTI	F12 Phantom Max 125	125	4	10371058	PEUGEOT	Speedfight 100 KAT 2T	100	2	10371058
MALAGUTI	F12 Phantom Max 200	200	4	10371057	PEUGEOT	Speedfight 2 *50 LC 2004->	50	2	10371052
MALAGUTI	F12 R LC euro 2	50	2	10371050	PEUGEOT	Squab *50 2T	50	2	10371052
MALAGUTI	F15 Firefox LC	50	2	10371055	PEUGEOT	St *50 2T	50	2	10371052
MALAGUTI	Madison 125	125	4	10371058	PEUGEOT	SV 250 4T	250	4	10371057
MALAGUTI	Madison 150	150	4	10371057	PEUGEOT	Sv Geo *50 2T	50	2	10371052
MALAGUTI	Madison 180	180	4	10371057	PEUGEOT	Trekker 100 KAT 2T	100	2	10371058
MALAGUTI	Madison 200	200	4	10371057	PEUGEOT	Vivacity *50 KAT 2T	50	2	10371055
MALAGUTI	Madison 250 (Motore Yamaha)	250	4	10371058	PEUGEOT	Vivacity 100 KAT 2T	100	2	10371058
MALAGUTI	Madison 3 - 125 (Motore Piaggio)	125	4	10371057	PEUGEOT	X-Fight *50 2T	50	2	10371055
MALAGUTI	Madison 3 - 250 (Motore Piaggio)	250	4	10371057	PEUGEOT	X-Fight 2 *50 LC 2004->	50	2	10371052
MALAGUTI	Madison RS 250 (Motore Quasar)	250	4	10371057	PEUGEOT	Zenith *50 2T	50	2	10371052
MALAGUTI	Spidermax GT 500 / 6 rulli	500	4	10371063	PIAGGIO	Beverly 125 4T	125	4	10371057
MALAGUTI	Spidermax GT 500 / 8 rulli	500	4	10371063	PIAGGIO	Beverly 200 4T	200	4	10371057
MALAGUTI	Yesterday	50	2	10371055	PIAGGIO	Beverly 250 4T	250	4	10371057
MBK	Active	50	2	10371055 *	PIAGGIO	Beverly 250 4T i.e.	250	4	10371057
MBK	Booster *50 euro 0-1	50	2	10371055 *	PIAGGIO	Beverly 400 4T i.e.	400	4	10371063

MARCA	MODELLO	CC	TEMPI	CODICE
BRAND	MODEL	CC	STROKE	ITEM
PIAGGIO	Beverly 500 4T i.e. / 6 rulli	500	4	10371063
PIAGGIO	Beverly 500 4T i.e. / 8 rulli	500	4	10371063
PIAGGIO	Beverly Cruiser 250 i.e.	250	4	10371057
PIAGGIO	Beverly Cruiser 500 i.e. / 8 rulli	500	4	10371063
PIAGGIO	Carnaby 125 4T	125	4	10371057
PIAGGIO	Carnaby 200 4T	200	4	10371057
PIAGGIO	Diesis *50 2T	50	2	10371052
PIAGGIO	Fly *50 2T	50	2	10371052
PIAGGIO	Fly 125 4T	125	4	10371057
PIAGGIO	Fly 150 4T	150	4	10371057
PIAGGIO	Free *50 2T	50	2	10371052
PIAGGIO	Hexagon 125 2T	125	2	10371056
PIAGGIO	Hexagon 150 2T	150	2	10371056
PIAGGIO	Hexagon 250 4T	250	4	10371057
PIAGGIO	Hexagon LX 125 2T	125	2	10371056
PIAGGIO	Hexagon LXT 180 2T	180	2	10371056
PIAGGIO	Liberty *50 2T	50	2	10371052
PIAGGIO	Liberty 125 4T euro 1-2 (Leader Engine)	125	4	10371057
PIAGGIO	Liberty 150 4T (Leader Engine)	150	4	10371057
PIAGGIO	Liberty 150 4T euro 1-2 (Leader Engine)	150	4	10371057
PIAGGIO	Liberty 200 4T (Leader Engine)	200	4	10371057
PIAGGIO	Liberty S 125 4T (Leader Engine)	125	4	10371057
PIAGGIO	Liberty S 200 4T (Leader Engine)	200	4	10371057
PIAGGIO	MP3 125 4T (Leader Engine)	125	4	10371057
PIAGGIO	MP3 250 4T i.e. (Quasar Engine)	250	4	10371057
PIAGGIO	MP3 400 4T i.e. (Master Engine)	400	4	10371063
PIAGGIO	NRG *50 LC	50	2	10371052
PIAGGIO	NRG Extreme	50	2	10371052
PIAGGIO	NRG Extreme LC	50	2	10371052
PIAGGIO	NRG Mc2 LC <-1997	50	2	10371052
PIAGGIO	NRG Mc2 LC 1998->	50	2	10371052
PIAGGIO	NRG Mc3 DD LC	50	2	10371052
PIAGGIO	NRG Mc3 DT	50	2	10371052
PIAGGIO	NRG Mc3 PureJet LC	50	2	10371052
PIAGGIO	NRG Power DD LC	50	2	10371052
PIAGGIO	NRG Power DT LC	50	2	10371052
PIAGGIO	NRG Power PureJet	50	2	10371052
PIAGGIO	NTT LC	50	2	10371052
PIAGGIO	Quartz LC	50	2	10371052
PIAGGIO	Sfera *50	50	2	10371054
PIAGGIO	Sfera *50 Rst	50	2	10371052
PIAGGIO	Sfera *75	75	2	10371054
PIAGGIO	Skipper 125 2T	125	2	10371056
PIAGGIO	Skipper 125 ST 4T (Leader Engine)	125	4	10371057
PIAGGIO	Skipper 150 2T	150	2	10371056
PIAGGIO	Skipper 150 ST 4T (Leader Engine)	150	4	10371057
PIAGGIO	Skipper LX 125	125	2	10371056
PIAGGIO	Skipper LXT 150	150	2	10371056
PIAGGIO	Super Hexagon GTX 125 4T	125	4	10371057
PIAGGIO	Super Hexagon GTX 180 4T	180	4	10371057
PIAGGIO	Typhoon *50 2T 2007->2010	50	2	10371054
PIAGGIO	Typhoon *50 2T euro 2 - 2011->	50	2	10371052
PIAGGIO	X7 125 4T euro 3 (Leader Engine)	125	4	10371057
PIAGGIO	X7 250 4T i.e. euro 3 (Quasar Engine)	250	4	10371057
PIAGGIO	X8 125 4T euro 2-3 (Leader Engine)	125	4	10371057
PIAGGIO	X8 150	150	4	10371057
PIAGGIO	X8 200 4T	200	4	10371057
PIAGGIO	X8 250 4T euro 2	250	4	10371057
PIAGGIO	X8 250 4T i.e. euro 3	250	4	10371057
PIAGGIO	X8 400 4T i.e. euro 3	400	4	10371063
PIAGGIO	X9 125 4T	125	4	10371057
PIAGGIO	X9 180 4T Amalfi	180	4	10371057
PIAGGIO	X9 200 4T	200	4	10371057
PIAGGIO	X9 250 4T	250	4	10371057
PIAGGIO	X9 250 4T Evolution	250	4	10371057
PIAGGIO	X9 500 Evolution - Street / 6 rulli	500	4	10371063
PIAGGIO	X9 500 Evolution Street / 8 rulli	500	4	10371063
PIAGGIO	XEvo 125 4T euro 3	125	4	10371057
PIAGGIO	XEvo 250 4T i.e. euro 3	250	4	10371057

MARCA	MODELLO	CC	TEMPI	CODICE
BRAND	MODEL	CC	STROKE	ITEM
PIAGGIO	XEvo 400 4T i.e. euro 3	400	4	10371063
PIAGGIO	Zip *50 2T	50	2	10371054
PIAGGIO	Zip *50 2T / 2000	50	2	10371052
PIAGGIO	Zip 125 4T (Leader Engine)	125	4	10371057
PIAGGIO	Zip Fast Rider	50	2	10371052
PIAGGIO	Zip SP LC ->2000	50	2	10371052
PIAGGIO	Zip SP LC 2001->	50	2	10371052
RIZZATO	Vamos	50	2	10371053
SUZUKI	Address Ah 50 2T	50	2	10371053
SUZUKI	AP *50 2T	50	2	10371053
SUZUKI	Burgman 125 K7 i.e.	125	4	10371055
SUZUKI	Burgman 200 4T i.e. euro 3	200	4	10371057
SUZUKI	Burgman 400 4T i.e. K 7	400	4	10371059
SUZUKI	Burgman AN 250 - 2001->	250	4	10371057
SUZUKI	Burgman AN 250 <-2000	250	4	10371057
SUZUKI	Estilete - UF 50 2T	50	2	10371053
SUZUKI	Katana *50 - 1999->	50	2	10371053
SUZUKI	Katana *50 <-1998	50	2	10371053
SUZUKI	Katana *50 LC <-1998	50	2	10371053
SUZUKI	Katana *50 LC 1999->	50	2	10371053
SUZUKI	Sepia *50 2T	50	2	10371053
SUZUKI	Sepia *50 ZZ 2T	50	2	10371053
SUZUKI	Sixteen 125 4T euro 3	125	4	10371055
SUZUKI	Sixteen 150 4T euro 3	150	4	10371055
SUZUKI	Street Magic	50	2	10371053
SUZUKI	Zillion *50 2T	50	2	10371053
SYM	DD *50 2T	50	2	10371052
YAMAHA	Aerox *50 euro 0-1	50	2	10371055
YAMAHA	Aerox *50 euro 2	50	2	10371055
YAMAHA	Aerox 100 2T	100	2	10371051
YAMAHA	Axis *50 2T	50	2	10371051
YAMAHA	Beluga *50 2T	50	2	10371050
YAMAHA	Breeze *50 2T	50	2	10371051
YAMAHA	BW'S *50 euro 0-1	50	2	10371055 *
YAMAHA	BW'S *50 NG euro 0-1	50	2	10371055 *
YAMAHA	BW'S *50 NG euro 2	50	2	10371052
YAMAHA	BW'S *50 Original / Naked 2T euro 2 > 2010	50	2	10371052
YAMAHA	BW'S 100 2T	100	2	10371051
YAMAHA	CRZ *50 2T	50	2	10371050
YAMAHA	CT *50 2T	50	2	10371050
YAMAHA	Cygnus 125 X 4T	125	4	10371057
YAMAHA	Jog *50	50	2	10371055 *
YAMAHA	Jog *50 ER	50	2	10371055 *
YAMAHA	Jog *50 R	50	2	10371055 *
YAMAHA	Jog *50 RR	50	2	10371055
YAMAHA	Jog *50 Z	50	2	10371055 *
YAMAHA	Majesty 125 4T	125	4	10371058
YAMAHA	Majesty 150 4T	150	4	10371057
YAMAHA	Majesty 180 4T	180	4	10371059
YAMAHA	Majesty 250 4T	250	4	10371058
YAMAHA	Majesty 400 4T <-2008	400	4	10371059
YAMAHA	Maxster 125 4T	125	4	10371058
YAMAHA	Maxster 150 4T	150	4	10371057
YAMAHA	Neo's *50 2T	50	2	10371055 *
YAMAHA	Neo's 100 2T	100	2	10371051
YAMAHA	Slider *50 2T	50	2	10371055
YAMAHA	Spy *50 2T	50	2	10371055 *
YAMAHA	Teo's 125 4T	125	4	10371058
YAMAHA	Teo's 150 4T	150	4	10371057
YAMAHA	Versity XC 300 4T	300	4	10371059
YAMAHA	Vino *50 2T	50	2	10371055 *
YAMAHA	Why *50 2T	50	2	10371055
YAMAHA	X-City 125 4T i.e.	125	4	10371059
YAMAHA	X-City 250 4T i.e.	250	4	10371058
YAMAHA	X-Max 125 4T i.e. <-2008	125	4	10371059
YAMAHA	X-Max 250 4T	250	4	10371058
YAMAHA	Zest *50 2T	50	2	10371051
YAMAHA	Zuma *50 2T	50	2	10371055 *

Limitatore di giri PHOTECO Rev Limiter PHOTECO

Limitatore di giri con telecomando. Applicabile su tutti i veicoli ad accensione elettronica, limita la potenza del motore e la velocità al livello impostato dall'utente.

Remote controlled Rev limiter. Available for all electronic ignitions, regulates engine power and speed based on user settings.

DESCRIZIONE	CODICE
DESCRIPTION	ITEM
LIMITATORE DI GIRI - REV LIMITER	10351024



Limitatore di giri SPEED LIMIT Rev Limiter SPEED LIMIT

Mini centralina digitale dotata di LED luminoso rosso e cablaggi per il montaggio.

Funzione limitatore di giri: il dispositivo limita il numero dei giri del motore e la velocità al valore impostato.

Funzione antifurto: con la limitazione al valore massimo il motore non sale di giri.

Inserimento: automatico all'avviamento. Disinserimento: codice personale.

Digital mini-ECU with red function LED and installation cables.

Engine speed limiter function: the device limits engine speed to a user defined value.

Anti-theft function: the limiter is set to minimum engine speed to prevent the engine from accelerating.

Switching on: on startin. Switching off: PIN code.

DESCRIZIONE	CODICE
DESCRIPTION	ITEM
LIMITATORE DI GIRI 1 PICK-UP - 1 PICK-UP REV LIMITER	10355558
LIMITATORE DI GIRI 2 PICK-UP - 2 PICK-UP REV LIMITER	10355560



Compensatore di Fluidi Fixed Space Compensator

Polmone compensatore a camera fissa in alluminio anodizzato. Recupera gli eccessi di alimentazione causati dalle decelerazioni e li restituisce durante le accelerazioni. Disponibile nei colori ARGENTO, VIOLA, BLU, NERO e completo di tutti i componenti necessari al montaggio.

Fixed space compensator in anodized aluminium. Recovers unburnt gases during deceleration and recycles them in acceleration. Available in SILVER, VIOLET, BLUE, BLACK complete with fitting kit.

COLORE	CODICE
COLOR	ITEM
ARGENTO <i>SILVER</i>	10450070
VIOLA <i>VIOLET</i>	10450071
BLU <i>BLUE</i>	10450073
NERO <i>BLACK</i>	10450075



Filtro Aria AIRTANK Air Filters AIRTANK

Filtri aria in spugna per migliorare le prestazioni e proteggere dalla polvere. Disponibili in vari diametri e inclinazioni.

*Sponge air filters to improve performance and dust protection.
Available in various diameters and positions.*



CODICE	Ø IMBOCCO	DESCRIZIONE	INCL.	TIPO FISSAGGIO	APPLICAZIONE
DESCRIPTION	Ø IMBOCCO	DESCRIPTION	INCL.	TIPO FISSAGGIO	APPLICATION
10161028	28	FILTRO SPUGNA / SPONGE AIR FILTER	-	FASCETTA / BAND	TK Y12P
10161032	32	FILTRO SPUGNA / SPONGE AIR FILTER	-	FASCETTA / BAND	DELLORTO PHBD - PHBG
10161036	36	FILTRO SPUGNA / SPONGE AIR FILTER	-	FASCETTA / BAND	DELLORTO PHBN - PHVA MIKUNI VM Ø 19 ÷ 22
10161039	39	FILTRO SPUGNA / SPONGE AIR FILTER	-	FASCETTA / BAND	DELLORTO PHBL
10161328	28	FILTRO SPUGNA / SPONGE AIR FILTER	30°	FASCETTA / BAND	TK Y12P
10161332	32	FILTRO SPUGNA / SPONGE AIR FILTER	30°	FASCETTA / BAND	DELLORTO PHBD - PHBG
10161336	36	FILTRO SPUGNA / SPONGE AIR FILTER	30°	FASCETTA / BAND	DELLORTO PHBN - PHVA MIKUNI VM Ø 19 ÷ 22
10161339	39	FILTRO SPUGNA / SPONGE AIR FILTER	30°	FASCETTA / BAND	DELLORTO PHBL
10161938	39	FILTRO SPUGNA / SPONGE AIR FILTER	90°	FASCETTA / BAND	DELLORTO PHBL

Disco Graduato Degree-Wheel

Disco graduato per il rilevamento della distribuzione e dell'angolo di anticipo dell'accensione.

Degree-wheel to check ports-open period and ignition advance.

DESCRIZIONE	CODICE
DESCRIPTION	ITEM
DISCO GRADUATO / DEGREE WHEEL	10070830



Lastre in Carbonio Carbon Plates for Reeds

DESCRIZIONE	DIMENSIONI mm	SPESSORE mm	CODICE
DESCRIPTION	DIMENSIONS mm	THICKNESS mm	ITEM
LASTRA CARBONIO PER LAMELLE	130 x 100	0,25	10382500
LASTRA CARBONIO PER LAMELLE	130 x 100	0,30	10383000
LASTRA CARBONIO PER LAMELLE	130 x 100	0,35	10383500

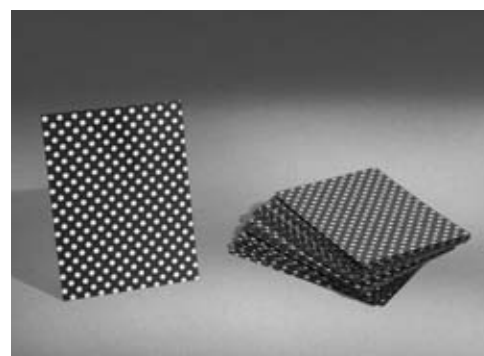

Gruppi Termici in Alluminio GForce Monofascia Aluminum Cylinder Kits GForce Single Ring

Realizzati in alluminio con riporto galvanico, sono caratterizzati da un diagramma di distribuzione ed una conformazione delle luci tali da garantire un compromesso ideale tra coppia e potenza massima erogate. Le teste sono state sviluppate per l'uso di benzina senza piombo. I pistoni sono ad 1 segmento per garantire il massimo delle prestazioni.

Made from aluminium with galvanized coating, the thermal units have a distribution diagram and conformation of the openings that provide the ideal compromise between the torque and maximum power supplied. The heads have been developed for use with unleaded petrol. The pistons are made in one segment to allow maximum performances.

MARCA	MODELLO	CC	TEMPI	CODICE
BRAND	MODEL	CC	STROKE	ITEM
APRILIA	MX *50 (dal 2007)	50	2	10051909
APRILIA	RS *50	50	2	10051909
APRILIA	RX *50 (dal 2007)	50	2	10051935
APRILIA	SX *50	50	2	10051935
APRILIA	Tuono *50	50	2	10051909
BETA	Enduro RR	50	2	10051909
BETA	Super Motard RR	50	2	10051909
BETA	Super Motard RR ALU	50	2	10051909
DERBI	GPR Nude *50 > 2006	50	2	10051935
DERBI	Senda DRD EVO SM 50	50	2	10051935
DERBI	Senda DRD PRO R 50	50	2	10051935
DERBI	Senda DRD PRO SM 50	50	2	10051935
DERBI	Senda DRD RACING R - SM 50	50	2	10051935
DERBI	Senda X-RACE R / X-RACE SM 50	50	2	10051935
DERBI	Senda X-TREME R / X-TREME SM 50	50	2	10051935
FANTIC	Caballero *50	50	2	10051909
HM	CR E 50	50	2	10051909
HM	Derapage 50 RR 11	50	2	10051909
HUSQVARNA	CH Racing	50	2	10051909
MALAGUTI	XSM *50	50	2	10051909
MBK	X-Power *50	50	2	10051909
PEUGEOT	XPS *50 2T	50	2	10051909
PEUGEOT	XR6 *50 2T LC	50	2	10051909
RIEJU	RS2 Matrix	50	2	10051909
SHERCO	HRD	50	2	10051909
YAMAHA	TZR *50 2T	50	2	10051909



Alberi motore | Crankshafts

MARCA	MODELLO	CC	TEMPI	CODICE
BRAND	MODEL	CC	STROKE	ITEM
APRILIA	MX *50 (dal 2007)	50	2	10080809
APRILIA	RS *50	50	2	10080809
APRILIA	RS *50 (dal 2006)	50	2	10080809
APRILIA	RX *50 (dal 2007)	50	2	10080835
APRILIA	SX *50	50	2	10080835
APRILIA	Tuono *50	50	2	10080809
BETA	Enduro RR	50	2	10080809
BETA	RR *50 Motard	50	2	10080804
BETA	Super Motard RR	50	2	10080809
BETA	Super Motard RR ALU	50	2	10080809
DERBI	GPR Nude *50 > 2006	50	2	10080835
DERBI	Senda DRD EVO SM 50	50	2	10080835
DERBI	Senda DRD PRO R 50	50	2	10080835
DERBI	Senda DRD PRO SM 50	50	2	10080835
DERBI	Senda DRD RACING R - SM 50	50	2	10080835
DERBI	Senda X-RACE R / X-RACE SM 50	50	2	10080835
DERBI	Senda X-TREME R / X-TREME SM 50	50	2	10080835
FANTIC	Caballero *50	50	2	10080809
HM	CR E 50	50	2	10080809
HM	Derapage 50 RR 11	50	2	10080809
HUSQVARNA	CH Racing	50	2	10080809
MALAGUTI	XSM *50	50	2	10080809
MALAGUTI	XTM *50	50	2	10080809
MBK	X-Power *50	50	2	10080809
PEUGEOT	XPS *50 2T	50	2	10080809
PEUGEOT	XR6 *50 2T LC	50	2	10080809
RIEJU	RS2 Matrix	50	2	10080809
SHERCO	HRD	50	2	10080809
YAMAHA	TZR *50 2T	50	2	10080809

Alberi motore realizzati in acciaio K2D trattato termicamente, lavorati con macchinari a controllo numerico, assemblati e centrati con la massima cura utilizzando cuscinetti di biella di altissima qualità e bielle specifiche per competizione.

Crankshafts made of K2D steel heat-treated, CNC machined, assembled and centered, top quality rods and rod bearings.

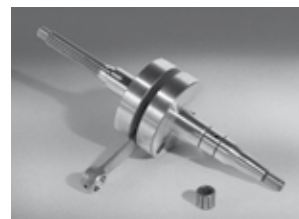

Impianti di Alimentazione Ø 21 | Carburettor Kits Ø 21

MARCA	MODELLO	CC	TEMPI	CODICE
BRAND	MODEL	CC	STROKE	ITEM
APRILIA	MX *50 (dal 2007)	50	2	10294996
APRILIA	Tuono *50	50	2	10294995
BETA	Enduro RR	50	2	10294995
BETA	Super Motard RR	50	2	10294995
BETA	Super Motard RR ALU	50	2	10294995
DERBI	GPR Nude *50 > 2004	50	2	10294998
DERBI	GPR Nude *50 > 2006	50	2	10294998
DERBI	Senda *50	50	2	10294997
HM	CR E 50	50	2	10294995
HM	Derapage 50 RR 11	50	2	10294995
HUSQVARNA	CH Racing	50	2	10294995
MALAGUTI	XSM *50	50	2	10294995
MBK	X-Power *50	50	2	10294995
PEUGEOT	XPS *50 2T	50	2	10294995
PEUGEOT	XR6 *50 2T LC	50	2	10294995
RIEJU	RS2 Matrix	50	2	10294995
SHERCO	HRD	50	2	10294996
YAMAHA	TZR *50 2T	50	2	10294995

Carburatori con diametro di 21 mm, adatti a tutti gli scooter elaborati. Vengono forniti con tutti gli accessori per il montaggio e già tarati per ogni singolo scooter.

Carburettor 21 mm, choke, suitable for all modified scooters. Supplied with all mounting accessories and pre-calibrated for each scooter.



Kit Molle Frizione Rinforzate | Strengthened Clutch Spring Kit

MARCA	MODELLO	CC	TEMPI	CODICE
BRAND	MODEL	CC	STROKE	ITEM
APRILIA	MX *50 (dal 2007)	50	2	10371061
APRILIA	RS *50	50	2	10371061
APRILIA	Tuono *50	50	2	10371061
BETA	Enduro RR	50	2	10371061
BETA	Super Motard RR	50	2	10371061
BETA	Super Motard RR ALU	50	2	10371061
DERBI	GPR Nude *50 > 2004	50	2	10371060
DERBI	GPR Nude *50 > 2006	50	2	10371060
DERBI	Senda *50	50	2	10371060
GILERA	GSM H@K	50	2	10371060
HM	CR E 50	50	2	10371061
HM	Derapage 50 RR 11	50	2	10371061
HUSQVARNA	CH Racing	50	2	10371061
MALAGUTI	XSM *50	50	2	10371061
MBK	X-Power *50	50	2	10371061
PEUGEOT	XPS *50 2T	50	2	10371061
PEUGEOT	XR6 *50 2T LC	50	2	10371061
RIEJU	RS2 Matrix	50	2	10371061
SHERCO	HRD	50	2	10371061
YAMAHA	TZR *50 2T	50	2	10371061

Molle frizione per scooter e maxi scooter realizzate in acciaio al silicio con diversi carichi in base al regime d'innesto. Tarature facilmente riconoscibili dalle varie colorazioni.

Clutch springs for scooters and maxi scooters made from silicon steel with differing loads depending on the coupling speed.

The calibrations are colour-coded.



Kit Lamelle per Pacco Lamellare Originale Reed Kit to fit the Original Valve Pack

MARCA	MODELLO	CC	TEMPI	CODICE
BRAND	MODEL	CC	STROKE	ITEM
APRILIA	MX *50 (dal 2007)	50	2	10387600
APRILIA	RS *50	50	2	10387600
APRILIA	Tuono *50	50	2	10387600
BETA	Enduro RR	50	2	10387600
BETA	Super Motard RR	50	2	10387600
BETA	Super Motard RR ALU	50	2	10387600
DERBI	GPR Nude *50 > 2004	50	2	10387601
DERBI	Senda *50	50	2	10387601
GILERA	GSM H@K	50	2	10387601
HM	CR E 50	50	2	10387600
HM	Derapage 50 RR 11	50	2	10387600
HUSQVARNA	CH Racing	50	2	10387600
MALAGUTI	XSM *50	50	2	10387600
MBK	X-Power *50	50	2	10387600
PEUGEOT	XR6 *50 2T LC	50	2	10387600
RIEJU	RS2 Matrix	50	2	10387600
SHERCO	HRD	50	2	10387600
YAMAHA	TZR *50 2T	50	2	10387600

Realizzate in fibra di carbonio, vengono fornite in diversi spessori a seconda del tipo di elaborazione effettuata e tipo di carburatore impiegato.

Made from carbon fiber in various thicknesses depending on the type of modification and carburettor used.

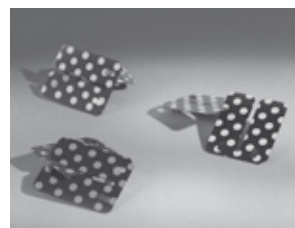



Gruppi Termici 75-80-102cc Cylinder Kits 75-80-102cc

Gruppi termici Pinasco per Vespa ed Ape 50 in ghisa e alluminio, l'ideale per chi vuole dare un po' di brio al proprio cinquantino. I kit non necessitano di particolari conoscenze tecniche per essere montati e si adattano facilmente a tutte le Vespa ed Ape 50cc 3 e 4 marce senza bisogno di lavorazioni specifiche. Le caratteristiche tecniche di questi cilindri sono una notevole coppia e consumi ridotti, la ghisa utilizzata di ottima qualità viene lavorata in modo da diminuire notevolmente gli attriti interni dando al motore fluidità, affidabilità e resistenza. L'alluminio con riporto al Nicasil conferisce ai gruppi termici Pinasco una robustezza eccezionale e una resistenza unica garantendo prestazioni superiori in tutti i regimi di utilizzo.

Pinasco cylinder kits for Vespa and Ape 50 cc in cast iron and aluminum. A must if you want to give some verve to your 50cc vehicle. These kits do not require technical experience to be installed and can be easily adapted to every Vespa and Ape 50 cc with 3 or 4 gears without any particular modifications. The technical characteristic of this cylinders will considerably increase the torque of your vehicle and will reduce the fuel consumption. The material is a very high quality cast iron and it is processed to reduce internal friction giving the engine resistance and reliability. The aluminum with Nicasil gives the engine an exceptional strength and a unique resistance offering superior performances in every regime of utilization.

25010880

GRUPPO TERMICO IN GHISA 80CC
CAST IRON CYLINDER KIT 80CC
50: APE - SPECIAL - PK



25010793

GRUPPO TERMICO
IN GHISA 102CC
CAST IRON CYLINDER
KIT 102CC
50: APE - SPECIAL - PK



25010850

GRUPPO TERMICO
IN GHISA 75CC
CAST IRON CYLINDER
KIT 75CC
50: VESPA AUTOMATICA



25011840

GRUPPO TERMICO
IN ALLUMINIO 102CC
ALUMINUM CYLINDER
KIT 102CC
50: APE - SPECIAL - PK

**25030794**

GRUPPO TERMICO
IN ALLUMINIO 125CC
ALUMINUM CYLINDER
KIT 125CC
50: APE - PRIMAVERA
ET3 - PK



**25031797**

GRUPPO TERMICO
IN ALLUMINIO
"ZUERA" SS 135CC
ALUMINIUM CYLINDER KIT
"ZUERA" SS 135CC
50: APE-PRIMAVERA-
ET3-PK



CODICE ITEM	PRODOTTO PRODUCT
25381102	COLLETTORE LAMELLARE COMPLETO COMPLETE INTAKE MANIFOLD
25381300	PACCO LAMELLARE VALVE PACK
25381400	GUIDAFLUSSI FLOW GUIDE
25387300	KIT LAMELLE REED KIT
25536802	COLLETTORE ASPIRAZIONE INTAKE MANIFOLD
25536305	MANICOTTO IN GOMMA COMPLETO COMPLETE RUBBER SLEEVE

25031798

GRUPPO TERMICO
IN ALLUMINIO
"ZUERA" SRV 135CC
ALUMINIUM CYLINDER KIT
"ZUERA" SRV 135CC
50: PRIMAVERA-ET3

CODICE ITEM	APPLICAZIONE APPLICATION	Ø / N° SEGMENTI Ø / N° RINGS	PISTONE COMPLETO PISTON KIT	SEGMENTO PISTON RING	SERIE SEGMENTI RING SET	TESTA HEAD	SERIE GUARNIZIONI GASKET SET
25010793	PIAGGIO VESPA 50 - APE 50 / GHISA	55/2	25121016 - Ø 55,0	-	25173424 - Ø 55,0	25243604	25331655
			25121031 - Ø 55,4		25173436 - Ø 55,4		
			25121032 - Ø 55,8		25173437 - Ø 55,8		
25010850	PIAGGIO VESPA 50 AUTOMATICA / GHISA	47/2	25121080	-	25173422	-	-
25010880	PIAGGIO VESPA 50 - APE 50 / GHISA	50/2	25121015 - Ø 50,0	-	25173423 - Ø 50,0	25243603	25331655
			25121027 - Ø 50,4		25173492 - Ø 50,4		
			25121028 - Ø 50,8		25173493 - Ø 50,8		
25011840	PIAGGIO VESPA 50 - APE 50 / ALLUMINIO	55/2	25121068	-	25173424	25243604	25331655
25030794	PIAGGIO VESPA 125 ET3 / ALLUMINIO	55/1	25121017	25113408	-	25243605	25331655
25031797	PIAGGIO VESPA 125 ET3-PK / ALLUMINIO / CC	57,5/1	25121012	25113450	-	25243614	25332203
25031798	PIAGGIO VESPA 125 ET3-PK / ALLUMINIO / CC / LAM	57,5/1	25121012	25113450	-	25243614	25332203

Gruppi termici 177cc Cylinder Kits 177cc

Gruppi termici Pinasco per Vespa a 2 e 3 travasi in ghisa e alluminio, l'ideale per chi vuole dare un po' di brio al proprio veicolo. I kit non necessitano di particolari conoscenze tecniche per essere montati e si adattano facilmente a tutte le Vespa da 125 a 150, 3-4 marce senza bisogno di lavorazioni specifiche. Le caratteristiche tecniche di questi cilindri sono una notevole coppia e consumi ridotti, la ghisa utilizzata di ottima qualità viene lavorata in modo da diminuire notevolmente gli attriti interni dando al motore fluidità, affidabilità e resistenza. L'alluminio con riporto al Nicasil conferisce ai gruppi termici Pinasco una robustezza eccezionale e una resistenza unica garantendo prestazioni superiori in tutti i regimi di utilizzo.

Pinasco cylinder kit for Vespa 2 or 3 transfer ports cast iron or aluminum the ideal to give your vehicle some verve. These kits do not require technical experience to be installed and can be easily adapted to every Vespa 125 or 150 with 3 or 4 gears without any particular modifications. The technical characteristic of this cylinder will considerably increase the torque of your vehicle and will reduce the fuel consumption. The material is a very high quality cast iron and it is processed to reduce internal friction giving the engine resistance and reliability. The aluminum with Nicasil gives the engine an exceptional strength and a unique resistance offering higher performances in every regime of utilization.



25030804

GRUPPO TERMICO IN GHISA 177CC
CAST IRON CYLINDER KIT 177CC
VESPA 125/150: VBN - VBB - GL - GT
GTR - SPRINT - SPRINT V.



**NUOVI
PISTONI
NEW
PISTONS**

25030805

GRUPPO TERMICO IN GHISA 177CC
CAST IRON CYLINDER KIT 177CC
VESPA 125/150: PX
LML START 2T - COSA

CODICE	APPLICAZIONE	Ø / N° SEGMENTI	PISTONE COMPLETO	SEGMENTO	SERIE SEGMENTI	TESTA	S/GUARNIZIONI
ITEM	APPLICATION	Ø / N° RINGS	PISTON KIT	PISTON RING	RING SET	HEAD	GASKET SET
25030804	PIAGGIO VESPA GT 125 2 TRAVASI / GHISA	63/2	25121074 - Ø 63,0 -> 2015	-	25173476 - Ø 63,0 -> 2015	25243606	25331653
			-	-	25173475 - Ø 63,0 <- 2014		
			25121038 - Ø 63,4 <- 2014	-	25173444 - Ø 63,4 <- 2014		
			25121039 - Ø 63,8 <- 2014	-	25173445 - Ø 63,8 <- 2014		
25030805	PIAGGIO VESPA PX 125 / GHISA	63/2	25121072 - Ø 63,0 -> 2015	-	25173476 - Ø 63,0 -> 2015	25243606	25331656
			-	-	25173475 - Ø 63,0 <- 2014		
			25121033 - Ø 63,4 <- 2014	-	25173444 - Ø 63,4 <- 2014		
			25121034 - Ø 63,8 <- 2014	-	25173445 - Ø 63,8 <- 2014		

25030803 = Cessata produzione / No more available



25030942

GRUPPO TERMICO IN ALLUMINIO 177CC
 ALUMINUM CYLINDER KIT 177CC
 VESPA 125/150: VBN - VBB - GL - GT
 GTR - SPRINT - SPRINT V.

25030941

GRUPPO TERMICO IN ALLUMINIO 177CC
 ALUMINUM CYLINDER KIT 177CC
 VESPA 125/150: PX -
 LML START 2T - COSA



CODICE	APPLICAZIONE	Ø / N° SEGMENTI	PISTONE COMPLETO	SEGMENTO	SERIE SEGMENTI	TESTA	S/GUARNIZIONI
ITEM	APPLICATION	Ø / N° RINGS	PISTON KIT	PISTON RING	RING SET	HEAD	GASKET SET
25030841	PIAGGIO VESPA PX 125 / ALLUMINIO <- 2013	63/2	25121071	-	25173476 -> 2015	25243606	25331603
					25173475 <- 2014		
25030842	PIAGGIO VESPA GT 125 2TR / ALLUMINIO <- 2013	63/2	25121075	-	25173476 -> 2015	25243606	25331659
					25173475 <- 2014		
25030941	PIAGGIO VESPA PX 125 / ALLUMINIO -> 2014	63/2	25121071	-	25173476 -> 2015	25243606	25331671
					25173475 <- 2014		
					OPTIONAL TUNING	63/1 - GFT	
					25173476		
25030942	PIAGGIO VESPA GT 125 2TR / ALLUMINIO -> 2014	63/2	25121075	-	25173476 -> 2015	25243606	25331659
					25173475 <- 2014		

Optional Tuning = Componenti Tuning / Performance Spares

GFT = Pistone grafitato / Graphitized piston

25030841 / 25030842 = Cessata produzione / No more available

Gruppi termici Vespa 177-190cc Candela centrale Cylinder Kits Vespa 177-190cc Central spark plug

Pinasco ha ampliato la gamma prodotti creando nuovi modelli di gruppi termici. L'avvento delle nuove teste a candela centrale per tutti i gruppi termici ha permesso di sviluppare nuovi kit per dare una scelta più ampia a tutti i preparatori. Per ottimizzare il montaggio delle nuove teste a candela centrale nei modelli in ghisa è stato realizzato l'incasso per la testa che garantisce una maggior tenuta e una migliore precisione di assemblaggio.

Pinasco expanded its range of products developing new models of cylinder kits. New central spark plug heads for all cylinders, now included inside our kits, give a greater choice to all tuning fans. To optimize the installation of the new central spark plug heads, the iron cylinders have been modified on the head plate with a centering side which gives a greater precision assembly.



25031805

GRUPPO TERMICO 177CC GHISA
CORSA 57 CANDELA CENTRALE
CYLINDER KIT 177CC CAST IRON
STROKE 57 CENTRAL SPARK PLUG
125/150: VESPA PX - LML STAR 2T - COSA

25032805

GRUPPO TERMICO 190CC GHISA
CORSA 60 CANDELA CENTRALE
CYLINDER KIT 190CC CAST IRON
STROKE 60 CENTRAL SPARK PLUG
125/150: VESPA PX - LML STAR 2T - COSA



25031804

GRUPPO TERMICO 177CC GHISA
CORSA 57 CANDELA CENTRALE 2 TRAVASI
CYLINDER KIT 177CC CAST IRON
STROKE 57 CENTRAL SPARK PLUG FOR 2 PORTS
125/150: VNB - VBB - GL - GT
GTR - SPRINT - SPRINT V.

CODICE	APPLICAZIONE		Ø / N° SEGMENTI	PISTONE COMPLETO	SEGMENTO	SERIE SEGMENTI	TESTA	S/GUARNIZIONI
ITEM	APPLICATION		Ø / N° RINGS	PISTON KIT	PISTON RING	RING SET	HEAD	GASKET SET
25031804	"PIAGGIO VESPA GT 125 2 TRAVASI / GHISA TESTA CANDELA CENTRALE"	AIR	63/2	25121074 - Ø 63,0 -> 2015	-	25173476 - Ø 63,0 -> 2015	25243700	25331653
				-		25173475 - Ø 63,0 <- 2014		
				-		25173444 - Ø 63,4 <- 2014		
				25121039 - Ø 63,8 <- 2014		25173445 - Ø 63,8 <- 2014		
25031805	"PIAGGIO VESPA PX 125 / GHISA TESTA CANDELA CENTRALE"	AIR	63/2	25121072 - Ø 63,0 -> 2015	-	25173476 - Ø 63,0 -> 2015	25243700	25331656
				-		25173475 - Ø 63,0 <- 2014		
				-		25173444 - Ø 63,4 <- 2014		
				25121034 - Ø 63,8 <- 2014		25173445 - Ø 63,8 <- 2014		
25032805	"PIAGGIO VESPA PX 125 / GHISA TESTA CANDELA CENTRALE / CORSA 60MM"	AIR	63/2	25121072 - Ø 63,0 -> 2015	-	25173476 - Ø 63,0 -> 2015	25243701	25331656
				-		25173475 - Ø 63,0 <- 2014		
				-		25173444 - Ø 63,4 <- 2014		
				25121034 - Ø 63,8 <- 2014		25173445 - Ø 63,8 <- 2014		
26030803	"PIAGGIO VESPA PX 125 / GHISA TESTA CANDELA CENTRALE / LAMELLARE"	AIR	63/2	25121072 - Ø 63,0 -> 2015	-	25173476 - Ø 63,0 -> 2015	25243700	25331656
				-		25173475 - Ø 63,0 <- 2014		
				-		25173444 - Ø 63,4 <- 2014		
				25121034 - Ø 63,8 <- 2014		25173445 - Ø 63,8 <- 2014		

26030803 = Cessata produzione / No more available



25031941

GRUPPO TERMICO 177CC ALLUMINIO
CORSA 57 CANDELA CENTRALE
 CYLINDER KIT 177CC ALUMINUM
STROKE 57 CENTRAL SPARK PLUG
 125/150: VESPA PX - LML STAR 2T - COSA

25032941

GRUPPO TERMICO 190CC ALLUMINIO
CORSA 60 CANDELA CENTRALE
 CYLINDER KIT 190CC ALUMINUM
STROKE 60 CENTRAL SPARK PLUG
 125/150: VESPA PX - LML STAR 2T - COSA

VESPA

25031942

GRUPPO TERMICO 177CC ALLUMINIO
CORSA 57 CANDELA CENTRALE
 CYLINDER KIT 177CC ALUMINUM
STROKE 57 CENTRAL SPARK PLUG
 125/150: VNB - VBB - GL - GT
 GTR - SPRINT - SPRINT V.

25032942

GRUPPO TERMICO 190CC ALLUMINIO
CORSA 60 CANDELA CENTRALE
 CYLINDER KIT 190CC ALUMINUM
STROKE 60 CENTRAL SPARK PLUG
 125/150: VNB - VBB - GL - GT
 GTR - SPRINT - SPRINT V.



CODICE	APPLICAZIONE	Ø / N° SEGMENTI	PISTONE COMPLETO	SEGMENTO	SERIE SEGMENTI	TESTA	S/GUARNIZIONI	
ITEM	APPLICATION	Ø / N° RINGS	PISTON KIT	PISTON RING	RING SET	HEAD	GASKET SET	
25031841	PIAGGIO VESPA PX 125 / ALLUMINIO / CANDELA CENTRALE < 2014	AIR	63/2	25121071	-	25173476 -> 2015 25173475 <- 2014	25243700	25331603
25031842	PIAGGIO VESPA GT 125 2TR / ALLUMINIO / CANDELA CENTRALE < 2014	AIR	63/2	25121075	-	25173476 -> 2015 25173475 <- 2014	25243700	25331659
25031941	PIAGGIO VESPA PX 125 / ALLUMINIO / CANDELA CENTRALE > 2014	AIR	63/2 - GFT	25121110	-	25173476	25243700	25331671
	OPTIONAL TUNING		63/1 - GFT	25121064	25113451	-		
25031942	PIAGGIO VESPA GT 125 2TR / ALLUMINIO / CANDELA CENTRALE > 2014	AIR	63/2	25121075	-	25173476 -> 2015 25173475 <- 2014	25243700	25331659
25032841	PIAGGIO VESPA PX 125 / ALLUMINIO / CANDELA CENTRALE / CORSA 60MM < 2014	AIR	63/2	25121071	-	25173476 -> 2015 25173475 <- 2014	25243701	25331603
25032941	PIAGGIO VESPA PX 125 / ALLUMINIO / CANDELA CENTRALE / CORSA 60MM > 2014	AIR	63/2 - GFT	25121110	-	25173476	25243701	25331671
	OPTIONAL TUNING		63/1 - GFT	25121064	25113451	-		
25032942	PIAGGIO VESPA GT 125 2TR / ALLUMINIO / CANDELA CENTRALE / CORSA 60MM > 2014	AIR	63/2	25121075	-	25173476 -> 2015 25173475 <- 2014	25243700	25331659

Optional Tuning = Componenti Tuning / Performance Spares

GFT = Pistone grafitato / Graphitized piston

25031841 / 25031842 / 25032841 = Cessata produzione / No more available

Gruppi termici Vespa 215-225-235cc Cylinder Kits Vespa 215-225-235cc

Il gruppo termico 215cc è il classico cilindro Pinasco dedicato a tutte le Vespa equipaggiate con alberi motore corsa originale 57mm, il 225cc è quello specifico per il montaggio con alberi motore corsa lunga 60mm, il 235cc con alberi motore corsa lunga 62mm. I gruppi termici corsa lunga vengono forniti con la testa specifica VRH. I cilindri sono realizzati in lega di alluminio con riporto al Nicasil che conferisce una robustezza eccezionale ed una resistenza unica garantendo prestazioni superiori a tutti i regimi di utilizzo.

The cylinder kit 215cc is the Pinasco classic, suitable on Vespa equipped with original 57mm stroke crankshafts, the 225cc is specific to fit the 60mm long stroke crankshaft, the 235cc to fit the 62mm long stroke crankshaft. The long stroke cylinder kits are supplied with VRH specific head. The cylinders are made of aluminum alloy Nikasil coated which gives exceptional strength and unique resistance allowing for superior performance at all rpm.



25030910

GRUPPO TERMICO IN ALLUMINIO
TESTA 4 PRIGIONIERI 215CC
ALUMINUM CYLINDER KIT
4 PRISONERS HEAD 215CC
200: VESPA PX - PE - COSA

25030911

GRUPPO TERMICO IN ALLUMINIO
TESTA 4 PRIGIONIERI
CORSA LUNGA 225CC
ALUMINUM CYLINDER KIT
4 PRISONERS HEAD
LONG STROKE 225CC
200: VESPA PX - PE - COSA

25031910

GRUPPO TERMICO
IN ALLUMINIO 215CC
TESTA 4 PRIGIONIERI
CANDELA CENTRALE
ALUMINUM
CYLINDER KIT 215CC
4 PRISONERS HEAD
CENTRAL SPARK PLUG
200: VESPA PX - PE
RALLY - COSA



**25032911**

GRUPPO TERMICO
IN ALLUMINIO
TESTA 8 PRIGIONIERI
CORSA LUNGA 225CC
ALUMINUM CYLINDER KIT
8 PRISONERS HEAD
LONG STROKE 225CC
200: VESPA PX - PE - COSA



Marcello Dibrogni e Andrea Revel Nutini hanno partecipato e portato a termine la gara di enduro **Transanatolia** con Vespa equipaggiate Pinasco

CODICE	APPLICAZIONE	Ø / N° SEGMENTI	PISTONE COMPLETO	SEGMENTO	SERIE SEGMENTI	TESTA	S/GUARNIZIONI
ITEM	APPLICATION	Ø / N° RINGS	PISTON KIT	PISTON RING	RING SET	HEAD	GASKET SET
25030810	PIAGGIO VESPA PX 213 / ALLUMINIO <- 2013	69/2	25125506	-	25173427 -> 2015 25173426 <- 2014	25243608	25331654
25030811	PIAGGIO VESPA PX 225 / ALLUMINIO <- 2013	69/2	25125506	-	25173427 -> 2015 25173426 <- 2014	25243609	25331654
25030910	PIAGGIO VESPA PX 213 / ALLUMINIO -> 2014	69/2	25125506	-	25173427 -> 2015 25173426 <- 2014	25243608	25331654
	OPTIONAL TUNING	69/1	25125508	25113452	-	25243610	
25030911	PIAGGIO VESPA PX 225 / ALLUMINIO -> 2014	69/2	25125506	-	25173427 -> 2015 25173426 <- 2014	25243609	25331654
	OPTIONAL TUNING	69/1	25125508	25113452	-	25243611	
25031810	PIAGGIO VESPA PX 213 / ALLUMINIO / CANDELA CENTRALE <- 2014	69/2	25125506	-	25173427 -> 2015 25173426 <- 2014	25243610	25331654
	25031910	PIAGGIO VESPA PX 213 / ALLUMINIO / CANDELA CENTRALE -> 2014	69/2	25125506	-	25173427 -> 2015 25173426 <- 2014	25243610
OPTIONAL TUNING		69/1	25125508	25113452	-		
25032811	PIAGGIO VESPA PX 225 / ALLUMINIO / CANDELA CENTRALE / CORSA 60MM <- 2014	69/2	25125506	-	25173427 -> 2015 25173426 <- 2014	25243611	25331654
	25032911	PIAGGIO VESPA PX 225 / ALLUMINIO / CANDELA CENTRALE / CORSA 60MM -> 2014	69/2	25125506	-	25173427 -> 2015 25173426 <- 2014	25243611
OPTIONAL TUNING		69/1	25125508	25113452	-		

Optional Tuning = Componenti Tuning / Performance Spares

25030810 / 25030811 / 25031810 / 25032811 = Cessata produzione / No more available

Kit Trasformazione Corsa Lunga 190-225cc Tuning Kit Long Stroke 190-225cc

Il perfetto abbinamento tra gruppo termico ed albero motore per la trasformazione corsa lunga della Vespa 125-150-200. Entrambi i componenti sono stati sviluppati e testati, insieme, al banco prova ed in pista.

The perfect combination between cylinder kit and crankshaft for a long-stroke tuning on Vespa 125-150-200. Both components have been developed and tested, together, on the dyno and track.

GRUPPO
TERMICO
+
ALBERO MOTORE
CYLINDER KIT
+
CRANKSHAFT

25361000

TUNING KIT CORSA LUNGA 60mm
GRUPPO TERMICO IN GHISA
25032805 + 25080826
TUNING KIT LONG STROKE 60mm
CAST IRON CYLINDER KIT
25032805 + 25080826
125/150: VESPA PX
LML STAR 2T - COSA



25361001

TUNING KIT CORSA LUNGA 60mm
GRUPPO TERMICO IN GHISA
25031804 + 25080902
TUNING KIT LONG STROKE 60mm
CAST IRON CYLINDER KIT
25031804 + 25080902
125/150: VNB - VBB - GL - GT
GTR - SPRINT - SPRINT V.



25361002

TUNING KIT CORSA LUNGA 60mm
GRUPPO TERMICO IN ALLUMINIO
25032941 + 25080826
TUNING KIT LONG STROKE 60mm
ALUMINUM CYLINDER KIT
25032941 + 25080826
125/150: VESPA PX
LML STAR 2T - COSA

**25361003**

TUNING KIT CORSA LUNGA 60mm
GRUPPO TERMICO IN ALLUMINIO
25031942 + 25080902
TUNING KIT LONG STROKE 60mm
ALUMINUM CYLINDER KIT
25031942 + 25080902
125/150: VNB - VBB - GL - GT
GTR - SPRINT - SPRINT V.

**25361004**

TUNING KIT CORSA LUNGA 60mm
GRUPPO TERMICO IN ALLUMINIO
25032911 + 25080827
TUNING KIT LONG STROKE 60mm
ALUMINUM CYLINDER KIT
25032911 + 25080827
200: VESPA PX - PE - COSA



Alberi Motore Anticipati Vespa Racing Crankshafts Vespa

Alberi motore Pinasco per Vespa realizzati in acciaio forgiato, lavorati a CNC e dalle superbe prestazioni. La forgiatura, la lavorazione meccanica, i numerosi trattamenti termici ed il centraggio realizzato su ogni singolo pezzo garantiscono un altissimo standard qualitativo e di affidabilità. La biella, ottenuta anch'essa per forgiatura, è stata progettata per garantire il massimo dell'affidabilità anche nelle condizioni d'uso più gravose, numerosi intagli e fori di lubrificazione eseguiti sul piede e testa di biella permettono una maggior lubrificazione delle gabbie a rulli, quelle di testa argentate, riducendo al minimo gli attriti e l'usura. Gli alberi motore Pinasco per Vespa sono il frutto di numerosi test al banco prova e su strada, l'innovativo disegno della spalla di aspirazione a cuneo, la scelta dei materiali, la cura dei dettagli e dell'assemblaggio, fanno di questo prodotto Pinasco un oggetto di qualità superiore.

Pinasco crankshaft for Vespa made of forged steel, CNC machined and with superb performance. Forging, machining, several heat treatments and centering one by one, make a product with high quality and reliability standard. The connecting rod is forged and designed for maximum reliability even under the heaviest use, many grooves and oil holes performed on its foot and head allow a greater lubrication of roller cages, the head one is silvered, minimizing the friction and wear. Pinasco crankshafts for Vespa are the result of testing on the dyno and road; the innovative design of the inlet, a wedge shoulder, the choice of materials, the attention to details and assembly make of this Pinasco product a higher quality object.

25080883

ALBERO MOTORE ANTICIPATO
CONO 19mm
CRANKSHAFT CONE 19mm
50: APE - SPECIAL - PK

25080884

ALBERO MOTORE ANTICIPATO
CONO 20mm
CRANKSHAFT CONE 20mm
50: PK XL - MODIFICA APE
SPECIAL

25080890

ALBERO MOTORE ANTICIPATO
CORSA 45mm - CONO 20mm
CRANKSHAFT STROKE 45mm
CONO 20mm
50: PK XL - MODIFICA APE
SPECIAL

NUOVO
NEW



25080885

ALBERO MOTORE ANTICIPATO
CONO 19mm
CRANKSHAFT CONE 19mm
125: APE - PRIMAVERA - ET3 - PK

25080888

ALBERO MOTORE ANTICIPATO
CONO 20mm
CRANKSHAFT CONE 20mm
125: PK XL - MODIFICA APE
PRIMAVERA - ET3



**25080886**

ALBERO MOTORE **ANTICIPATO**
 CORSA ORIGINALE 57mm
 CRANKSHAFT STROKE 57mm
 200: VESPA PX - PE - COSA

25080827

ALBERO MOTORE **ANTICIPATO** CORSA LUNGA 60mm
 CRANKSHAFT LONG STROKE 60mm
 200: VESPA PX - PE - COSA

25080904

ALBERO MOTORE **ANTICIPATO** CORSA LUNGA 60mm
 CRANKSHAFT LONG STROKE 60mm
 200: VESPA RALLY FEMSA

25080887

ALBERO MOTORE **ANTICIPATO**
 CORSA ORIGINALE 57mm
 CRANKSHAFT STROKE 57mm
 125/150: VESPA PX
 LML STAR 2T - COSA

25080826

ALBERO MOTORE **ANTICIPATO**
 CORSA LUNGA 60mm
 CRANKSHAFT LONG STROKE 60mm
 125/150: VESPA PX - LML STAR 2T - COSA



NUOVO
NEW

25080905

ALBERO MOTORE **ANTICIPATO**
 CORSA ORIGINALE 52mm
 CRANKSHAFT ORIGINAL STROKE 52mm
 125: VESPA T5

Albero anticipato Vespa VNB-GT Tuning Crankshaft Vespa VNB-GT

Albero motore anticipato realizzato per ottenere le massime prestazioni con i gruppi termici Pinasco 2 Travasi. Garantisce un notevole incremento di prestazioni lasciando inalterata l'affidabilità e può essere utilizzato anche su motori completamente originali. La forma dello spallamento lato volano è stata mantenuta il più possibile simile all'originale, mentre quella del lato aspirazione è stata anticipata e ottimizzata nella fluidodinamica.

Advanced crankshaft made to get the maximum performance with Pinasco 2 ports cylinder kits. It gets a high increase in performance while still retaining the reliability. This kind of crankshaft can also be used on completely original engines, the shape of the shoulder was kept as well as the original while the intake side has been advanced and the fluid dynamics has been optimized.

25080901

ALBERO MOTORE **ANTICIPATO**
CORSA ORIG. 57mm
CRANKSHAFT STROKE 57mm
125/150: GT - GTR - SPRINT - SPRINT V.

25080902

ALBERO MOTORE **ANTICIPATO**
CORSA 60mm con distanziale
CRANKSHAFT STROKE 60mm
with spacer
125/150: VNB - VBB - GL - GT
GTR - SPRINT - SPRINT V.

NUOVO
NEW



25080900

ALBERO MOTORE **ANTICIPATO** CORSA ORIG. 57mm
CRANKSHAFT STROKE 57mm
125/150: VNB - VBB - GL



25080903

ALBERO MOTORE CORSA ORIG. 57mm
CRANKSHAFT STROKE 57mm
125/150: VM1-2-3 - VL1-2-3
MOTORI 5% / ENGINE 5%

Pinasco AIRBOX Vespa Large

Pinasco Airbox è il coperchio filtro maggiorato del 120% per incrementare il volume d'aria all'interno della scatola filtro così da aumentare le prestazioni del motore soprattutto ai bassi regimi. Nelle elaborazioni l'aumento della cilindrata e delle dimensioni dei carburatori riduce l'efficienza del sistema di aspirazione a causa di un limitato volume d'aria che spesso non è sufficiente ad alimentare il motore, Pinasco Airbox, invece, grazie all'incremento del volume interno della scatola filtrante, permette al motore di "respirare" e di "rispondere" in modo efficace alla continua apertura della valvola gas. Pinasco Airbox si monta solo sulle scatole filtro Vespa Arcobaleno ed è l'accessorio ideale per incrementare le prestazioni di tutti i carburatori SI e VRX.

Pinasco Airbox is the big filter cover to increase by 120% the volume of the air inside the airbox, improving the engine performance especially at low rpm. The increasing of the engine displacement and the size of carburetors reduce the efficiency of the intake system due to a limited volume of air which is not often enough to fuel the engine. Pinasco Airbox, thanks to the internal volume growth of the airbox, allows the engine to "breathe" and to react well to the continuous opening of the throttle valve. Pinasco Airbox can be assembled only on Vespa Arcobaleno, it's the best accessory to enhance the performance of carburetors SI and VRX.

25070130

AIRBOX
125/150/200:
CON SCATOLA FILTRO
VESPA ARCOBALENO
WITH FILTER BOX
VESPA ARCOBALENO

25070131

AIRBOX
125/150:
CON SCATOLA FILTRO
WITH FILTER BOX
VESPA 125/150:
VNB - VBB - GL - GT - GTR
SPRINT - SPRINT V.
PX 125-150 PRIMA SERIE



Volano Magnete Alleggerito Lightened Flywheel

Volano Magnete Pinasco Elettronico per Vespa PX 125-150-200 caratterizzato da un peso inferiore all'originale del 50% che conferisce al motore un maggiore scatto da fermo e prestazioni superiori all'originale a tutti i regimi di rotazione. Caratterizzato da un'anima in alluminio pressofusa e da un involucro esterno realizzato in fibra, il volano Pinasco pesa 1,6Kg e viene equilibrato per eliminare qualsiasi vibrazione.

Electronic Pinasco Flywheel for Vespa PX 125-150-200 characterized by a lower weight to the original 50% of which gives the engine a greater release from the original firm and higher performance on all engine speeds. Featuring cast aluminum core and an outer casing made of fiber, the flywheel Pinasco weighs 1.6 kg. and is balanced to eliminate vibrations.

25060832

VOLANO MAGNETE VESPA 1,6kg
FLYWHEEL VESPA 1,6kg
125/150/200: VESPA PX - LML STAR 2T - COSA



Accensione Elettronica Pinasco Flytech Electronic Ignition Pinasco Flytech

PINASCO FLYTECH. Accensione Anticipo Variabile 12V 90W

L'accensione ad anticipo variabile PINASCO FLYTECH è frutto di innumerevoli ricerche e sviluppi volti a realizzare un prodotto di altissima qualità, affidabile e duraturo nel tempo. Il Volano PINASCO FLYTECH è stato realizzato con differenti pesi per tutti i modelli di Vespa VNB-GT-LML-COSA SPRINT-PX. I pesi dei volani sono di 1,6kg e 1,8kg.

CARATTERISTICHE

- Il rotore superleggero ha una paratia interna in acciaio che protegge i magneti e lo statore in caso di rottura dell'albero motore.
- Le zavorre ricavate dal pieno, non da un tubo, sono perfettamente equilibrate e zincate.
- I coni volano, ricavati dal pieno, sono predisposti per l'utilizzo degli estrattori originali Piaggio così da semplificare lo smontaggio, la superficie viene nichelata per resistere agli agenti atmosferici e alla corrosione, mantenendo il filetto interno sempre in perfette condizioni.
- La ventola di raffreddamento in nylon presenta un profilo delle alette maggiorato per raffreddare maggiormente il gruppo termico anche nelle condizioni più gravose, aumentando il flusso d'aria del 20%.
- Il supporto dello statore è in alluminio pressofuso con una scala graduata che permette anche agli appassionati meno esperti una perfetta regolazione del l'accensione.

PINASCO FLYTECH. Variable Ignition System 12V 90W

The FLYTECH variable ignition system by PINASCO is the result of a long research and development process aimed at delivering a high-quality, reliable and long-lasting product. The PINASCO FLYTECH flywheel, made with different weights for all models Vespa VNB-GT-LML-COSA-SPRINT-PX. The weights of the flywheels are 1.6 kg and 1.8 kg.

FEATURES

- The super light rotor has an internal steel bulkhead which protects both the magnets and the stator in case of crankshaft breakage.
- The ballasts are machined from solid, not from tube, they are perfectly well-balanced and zinc-plated.
- The flywheel cones, machined from the solid, are prearranged for Piaggio original extractors in order to ease removal. Their surface is nickel-plated to resist weathering action and corrosion maintaining a perfect thread on the inside.
- The nylon cooling fan presents an enhanced fin profile aimed at keeping the engine cool even in the worst conditions, by increasing by 20% the air flux.
- The die-cast aluminium stator plate guarantees maximum resistance and features a graduated scale which allows even the unexperienced to set the ignition perfectly.

- 25356833** ACCENSIONE FLYTECH FLYTECH IGNITION SYSTEM VESPA 50-125 PRIMAVERA ET3-PK Ø 19 / KG. 1,1
- 25356834** ACCENSIONE FLYTECH FLYTECH IGNITION SYSTEM VESPA 50-125 PK XL Ø 20 / KG. 1,1
- 25356835** ACCENSIONE FLYTECH FLYTECH IGNITION SYSTEM VESPA 50-125 PRIMAVERA ET3-PK Ø 19 / KG. 1,4
- 25356836** ACCENSIONE FLYTECH FLYTECH IGNITION SYSTEM VESPA 50-125 PRIMAVERA ET3-PK Ø 19 / KG. 0,9
- 25356837** ACCENSIONE FLYTECH FLYTECH IGNITION SYSTEM VESPA 50-125 PK XL Ø 20 / KG. 0,9
- 25356844** ACCENSIONE FLYTECH FLYTECH IGNITION SYSTEM VESPA 50-125 PK XL Ø 20 / KG. 1,4
- 25356849** ACCENSIONE FLYTECH FLYTECH IGNITION SYSTEM VESPA 50-125 PK XL Ø 20 / KG. 1,6
- 25356855** ACCENSIONE FLYTECH FLYTECH IGNITION SYSTEM VESPA 50-125 PK XL Ø 19 / KG. 1,6



Accensione Elettronica Pinasco Flytech Electronic Ignition Pinasco Flytech

ACCENSIONE FLYTECH FLYTECH IGNITION SYSTEM

APE 50 avviamento elettrico
APE 50 electric starter

PK 50/125 avviamento elettrico
PK 50/125 electric starter



25356857 ACCENSIONE FLYTECH
APE 50 CON AVVIAMENTO
ELETTRICO Ø 20 / KG. 1,45
FLYTECH IGNITION SYSTEM
APE 50 WITH RING GEAR FOR
ELECTRIC STARTER Ø 20 / KG. 1,45

NUOVA
ACCENSIONE
APE

NEW
IGNITION
APE

VESPA



25356831 ACCENSIONE FLYTECH
C/INGRANAGGIO AVVIAMENTO
ELETTRICO Ø 20 / KG. 1,6
FLYTECH IGNITION SYSTEM
W/RING GEAR FOR ELECTRIC
STARTER Ø 20 / KG. 1,6
VESPA 125/150/200
PX-PE-LML-COSA

Accensione Elettronica Pinasco Flytech "VESPA OLD" Electronic Ignition Pinasco Flytech "VESPA OLD"

Vespa 125/150/200 PX-PE-LML-COSA

25356832

ACCENSIONE FLYTECH Ø 20 / KG. 1,6
FLYTECH IGNITION SYSTEM Ø 20 / KG. 1,6

25356843

ACCENSIONE FLYTECH Ø 20 / KG. 0,9
FLYTECH IGNITION SYSTEM Ø 20 / KG. 0,9

25356845

ACCENSIONE FLYTECH Ø 20 / KG. 1,1
FLYTECH IGNITION SYSTEM Ø 20 / KG. 1,1

25356846

ACCENSIONE FLYTECH Ø 20 / KG. 1,4
FLYTECH IGNITION SYSTEM Ø 20 / KG. 1,4

Vespa 125 T5

25356850

ACCENSIONE FLYTECH VESPA T5 KG. 1,6
FLYTECH IGNITION SYSTEM VESPA T5 KG. 1,6

25356851

ACCENSIONE FLYTECH VESPA T5 KG. 1,4
FLYTECH IGNITION SYSTEM VESPA T5 KG. 1,4



VESPA 125/150 VNB-GT-SPRINT-GS-SS-SPORT-RALLY

25356838

ACCENSIONE FLYTECH Ø 17 / KG. 1,6
FLYTECH IGNITION SYSTEM Ø 17 / KG. 1,6

VESPA 125/150 GS-SS-RALLY

25356852

ACCENSIONE FLYTECH VESPA GS KG. 1,6
FLYTECH IGNITION SYSTEM VESPA GS KG. 1,6

25356853

ACCENSIONE FLYTECH VESPA SS KG. 1,6
FLYTECH IGNITION SYSTEM VESPA SS KG. 1,6

25356854

ACCENSIONE FLYTECH VESPA RALLY KG. 1,6
FLYTECH IGNITION SYSTEM VESPA RALLY KG. 1,6



ACCENSIONE FLYTECH PER VESPA VL1-2-3 VM1-2-3 e motori 5% PINASCO FLYTECH FOR VESPA VL1-2-3 VM1-2-3 and engines mix 5%

Pinasco ha realizzato per tutti gli appassionati delle Vespa anni 50 un'accensione elettronica 6-12V ad anticipo variabile esteticamente simile a quella originale ma con tutti i vantaggi di un prodotto moderno ed affidabile. La nuova Pinasco Flytech Vespa anni 50 è perfettamente intercambiabile all'originale senza eseguire nessuna modifica all'impianto elettrico, mantenendo, quindi, la reversibilità. Viene fornita con tutti gli accessori necessari al montaggio, la ventola in nylon caricato è uguale a quella originale e quindi non modifica l'estetica del veicolo.

I vantaggi sono molteplici:

- eliminazione delle puntine condensatore.
- aumento della luminosità grazie all'impianto elettrico da 6 o 12V.
- completa affidabilità.
- facilità nel montaggio e reversibilità totale.

Pinasco has made for all Vespa Fifties fans an electronic variable ignition 6-12V similar to the original, but with all the advantages of a modern and reliable product. The new Pinasco Flytech for Vespa Fifties is perfectly interchangeable with the original electrical system without making any changes, it keeps the reversibility and it's supplied with all installation accessories. The fan, made of nylon, is the same as the original, it does not change the aesthetics of the vehicle. Multiple benefits:

- the electronic pick-up replaces the tacks/capacitor.
- Increases the brightness thanks to the electrical system 6 or 12V.
- full reliability.
- easy assembly and full reversibility.

NUOVA
ACCENSIONE
VESPA FARO
BASSO

NEW
IGNITION VESPA
FARO BASSO



25356856 ACCENSIONE FLYTECH Ø 17 / KG. 1,6
FLYTECH IGNITION SYSTEM Ø 17 / KG. 1,6
VESPA 125/150 VM1-2-3 - VL1-2-3 - MOTORI 5%

25356858 ACCENSIONE FLYTECH Ø 17 / KG. 1,6
FLYTECH IGNITION SYSTEM Ø 17 / KG. 1,6
VESPA 150 GS VS1-2-3-4-5

CODICE	APPLICAZIONE	VOLANO	PIATTO STATORE COMPLETO	STATORE	CDI	VENTOLA	REGOLATORE	STAFFA COMPL.	DISTANZIALE
ITEM	APPLICATION	FLYWHEEL	STATOR PLATE COMPLETE	STATOR	CDI	FAN	REGULATOR	BRACKET COMPLETE	SPACER
25356831	VESPA PX 125-150-200 C/AVV. ELETTR. Ø 20 / KG. 1,8	25066831	25350801	25350051	25350010	25061000	-	-	-
25356832	VESPA PX 125-150-200 Ø 20 / KG. 1,6	25066832	25350801	25350051	25350010	25061000	25350021	-	-
25356833	VESPA 50-125 ET3 Ø 19 / KG. 1,1	25066833	25350802	25350051	25350010	25061001	25350021	25351017	-
25356834	VESPA 50-125 PK XL Ø 20 / KG. 1,1	25066834	25350802	25350051	25350010	25061001	25350021	25351017	-
25356835	VESPA 50-125 ET3 Ø 19 / KG. 1,4	25066835	25350802	25350051	25350010	25061001	25350021	25351017	-
25356836	VESPA 50-125 ET3 Ø 19 / KG. 0,9	25066836	25350802	25350051	25350010	25061001	25350021	25351017	-
25356837	VESPA 50-125 PK XL Ø 20 / KG. 0,9	25066837	25350802	25350051	25350010	25061001	25350021	25351017	-
25356838	VESPA VNB-GT Ø 17 / KG. 1,6	25066838	25350801	25350051	25350010	25061000	25350021	25351018	-
25356843	VESPA PX 125-150-200 Ø 20 / KG. 0,9	25066843	25350801	25350051	25350010	25061000	25350021	-	-
25356844	VESPA 50-125 PK XL Ø 20 / KG. 1,4	25066844	25350802	25350051	25350010	25061001	25350021	25351017	-
25356845	VESPA PX 125-150-200 Ø 20 / KG. 1,1	25066845	25350801	25350051	25350010	25061000	25350021	-	-
25356846	VESPA PX 125-150-200 Ø 20 / KG. 1,4	25066846	25350801	25350051	25350010	25061000	25350021	-	-
25356849	VESPA 50-125 PK XL Ø 20 / KG. 1,6	25066849	25350802	25350051	25350010	25061001	25350021	25351017	-
25356850	VESPA T5 KG. 1,6	25066850	25350803	25350051	25350010	25061000	25350021	-	-
25356851	VESPA T5 KG. 1,4	25066851	25350803	25350051	25350010	25061000	25350021	-	-
25356852	VESPA 160 GS KG. 1,6	25066852	25350804	25350051	25350010	25061000	25350020	25351018	99558502
25356853	VESPA SS KG. 1,6	25066853	25350804	25350051	25350010	25061000	25350020	25351018	99558502
25356854	VESPA RALLY KG. 1,6	25066854	25350805	25350051	25350010	25061000	25350020	-	-
25356855	VESPA 50-125 PK Ø 19 / KG. 1,6	25066855	25350802	25350051	25350010	25061001	25350021	25351017	-
25356856	VESPA 125/150 VM1-2-3 - VL1-2-3 - MOTORI 5% Ø 17 / KG. 1,6	25066856	25350806	25350051	25350010	25061002	25350020	25351016	99558503
25356857	APE 50 C/AVV. ELETTR. Ø 20 / KG. 1,45	25066857	25350807	25350051	25350010	25061001	-	-	-
25356858	VESPA 150 GS / VS1-2-3-4-5 Ø 17 / KG. 1,6	25066858	-	25350051	25350010	25061002	25350020	25351016	99558503

Cerchio Ruota Vespa Tubeless 2.10x10 Scomponibile in alluminio Light alloy modular tubeless rim for Vespa

Cerchio ruota in lega leggera tubeless scomponibile, cioè con la possibilità di essere aperto per la sostituzione del pneumatico, per tutte le Vespa con ruote 10". Il cerchio Tubeless Scomponibile Pinasco ha un canale 2.10 perfettamente centrato al telaio Vespa così da mantenere il massimo della stabilità sia sulle Vespa Large frame che Small frame. La peculiarità del sistema Tubeless Pinasco è quella di avere un cerchio completamente reversibile, infatti, la posizione della valvola è stata mantenuta nello stesso punto del cerchio originale, in caso di foratura o rottura del pneumatico è possibile l'inserimento di una camera d'aria standard per Vespa senza dover eseguire nessuna modifica. Il Cerchio tubeless Pinasco Scomponibile è stato progettato per garantire la massima rigidità strutturale in ogni condizione di guida, gli spallamenti sono stati rinforzati per poter ricavare all'interno una cava per l'OR di tenuta. L'anti-stallonamento viene ottenuto da lavorazione meccanica, tutte le superfici sono perfettamente arrotondate per facilitare il montaggio del pneumatico senza accessori particolari.

Light alloy modular tubeless rim to be opened for the replacement of the tire, for all Vespa with wheels 10". The Pinasco Modular Tubeless Rim has a channel 2:10 perfectly centered to the frame Vespa to get the maximum stability both on Vespa Large frame and Small frame. The peculiarity of the Pinasco's system is to have a rim completely reversible, in fact, the position of the air valve stay at the same point of the original rim, in case of puncture or tire failure is possible to insert a standard tube for Vespa without performing any changes. The Pinasco Modular Tubeless Rim is designed for maximum toughness in all driving conditions; the shoulders have been reinforced in order to get into a groove for the O-ring seal. The anti-bead-breaking is obtained by mechanical processing, all surfaces are perfectly rounded to facilitate mounting of the tire without special accessories.



25471000

CERCHIO VESPA 2.10 X 10
TUBELESS SCOMPONIBILE ALU LUCIDO
POLISHED MODULAR TUBELESS RIM

25471002

CERCHIO VESPA 2.10 X 10
TUBELESS SCOMPONIBILE
VERNICIATO NERO
BLACK PAINTED MODULAR
TUBELESS RIM

25471001

CERCHIO VESPA 2.10 X 10
TUBELESS SCOMPONIBILE
VERNICIATO GRIGIO
ALUMINIUM PAINTED
MODULAR TUBELESS RIM



CODICE	APPLICAZIONE	KIT REVISIONE (O-RING + VALVOLA)
ITEM	APPLICATION	REPAIR KIT (O-RING + VALVE)
25471000	CERCHIO VESPA 2.10 X 10 TUBELESS SCOMPONIBILE ALU LUCIDO	25331801
25471001	CERCHIO VESPA 2.10 X 10 TUBELESS SCOMPONIBILE GRIGIO	25331801
25471002	CERCHIO VESPA 2.10 X 10 TUBELESS SCOMPONIBILE NERO	25331801

Frizione Power Clutch 12 molle Power Clutch 12 springs

Il kit Pinasco Power Clutch raccoglie tutti i componenti Pinasco dedicati alle frizioni per Vespa Small Frame in un unico e completo kit intercambiabile al 100% con l'originale. Il kit Pinasco Power Clutch comprende le 12 molle rinforzate, i dischi specifici in sughero, i piatti frizione e il cestello specifico, per fornire un prodotto completo e pronto per essere facilmente installato.

Il kit Pinasco Power Clutch è disponibile per tutte le Vespa Small Frame con frizione mono molla.

The Pinasco Power Clutch kit merges all Pinasco components for Vespa Small Frame clutch in a unique and complete kit perfectly interchangeable with the original. The Pinasco Power Clutch includes the 12 springs Kit reinforced, specific cork disk, specific plates and clutch basket to offer to the customers a complete product ready to be installed on every clutch.

The Pinasco Power Clutch kit may be installed on all Vespa Small.



25090721

FRIZIONE POWER CLUTCH 12 MOLLE
POWER CLUTCH 12 SPRINGS
VESPA 50 - PRIMAVERA
ET3 - PK - APE



25090722

DISCHI FRIZIONE BLACK
BLACK CORK DISK
VESPA 50 - PRIMAVERA
ET3 - PK - APE



25090720

FRIZIONE LIGHT CLUTCH 12 MOLLE
LIGHT CLUTCH 12 SPRINGS
VESPA 50 - PRIMAVERA
ET3 - PK - APE



25090829

SERIE MOLLE
DI RICAMBIO 12pz +12pz
PER 25090720
REPLACEMENT
SPRINGS 12pcs + 12pcs
for 25090720
VESPA 50 - PRIMAVERA
ET3 - PK - APE

Frizione Power Clutch 6/7 molle Power Clutch 6/7 springs

Il kit Pinasco Power Clutch raccoglie tutti i componenti Pinasco dedicati alle frizioni per Vespa Large Frame in un unico e completo kit intercambiabile al 100% con l'originale. Il kit Pinasco Power Clutch comprende le molle rinforzate Spring Force con i bicchierini forati, il cuscinetto speciale Clutch Slider ed il cestello frizione Ring Clutch, inoltre vengono aggiunti dischi specifici in sughero per fornire un prodotto completo e pronto per essere facilmente installato. Il kit Pinasco Power Clutch è disponibile per tutte le Vespa prodotte dal 1960 con frizione a 6 e 7 molle ed è consigliato a tutti gli utenti con Vespa equipaggiate di motori 177, 215 e 225cc.

The Pinasco Power Clutch kit merges all Pinasco components for Vespa Large Frame clutch in a unique and complete kit perfectly interchangeable with the original. The Pinasco Power Clutch kit includes the Spring Force, reinforced springs with drilled caps, the special bearing Clutch Slider and the clutch cage Ring Clutch. Specific cork disks are also included to offer to the customers a complete product ready to be installed on every clutch. The Pinasco Power Clutch kit may be installed on all Vespa built from 1960 with clutch of 6 or 7 springs and it is recommended for all Vespa with engine 177, 215 and 225 cc



25090500

FRIZIONE COMPLETA POWER CLUTCH 6 MOLLE
POWER CLUTCH 6 SPRINGS
125/150: VESPA PX - VNB - GT - LML - COSA

25090501

FRIZIONE COMPLETA POWER CLUTCH 7 MOLLE
POWER CLUTCH 7 SPRINGS
200: VESPA PX - RALLY - LML - COSA - T5



Ring Clutch 6/7 molle Ring Clutch 6/7 springs

Il cestello Pinasco Ring Clutch 6/7 molle viene rinforzato con un anello speciale in acciaio saldato accuratamente sui petali esterni della frizione, le battute dei dischi sono temprate e successivamente brunite.

The Pinasco Ring Clutch 6/7 springs is reinforced with a special steel ring welded on the external part of the clutch, a hardening treatment makes the seat of the discs more resistant, the basket is burnished.

25090600

RING CLUTCH 6 MOLLE
RING CLUTCH 6 SPRINGS
125/150: PX - VNB - GT - LML - COSA

25090601

RING CLUTCH 7 MOLLE
RING CLUTCH 7 SPRINGS
200: PX - RALLY - COSA - LML - T5



Supporto 6/7 molle 6/7 Springs support

Il supporto porta molle è stato completamente riprogettato, come materiale è stato scelto l'acciaio C40, la pista di scorrimento della bronzina o del cuscinetto Clutch Slider è stata temprata per induzione e successivamente rettificata per garantire la massima scorrevolezza e la massima durata, sul piano porta molle sono stati realizzati fori di alleggerimento.

The springs support has been completely redesigned, as material was selected steel C40, the raceway of the bearing Clutch Slider has been hardened by induction and then grinding to ensure maximum smoothness and durability, in the springs support was made lightening holes.

25090606

SUPPORTO 6 MOLLE
6 SPRINGS SUPPORT
125/150: VNB - VBB - GL - GT - GTR
SPRINT - SPRINTV. PX - LML - COSA

25090607

SUPPORTO 7 MOLLE
7 SPRINGS SUPPORT
200: VESPA PX - PE - RALLY - LML
COSA - T5

Frizione Light Clutch 6/7 molle Light Clutch 6/7 springs

Il kit pinasco Light Clutch contiene:

- cestello rinforzato e temprato
- dischi in sughero e acciaio dedicati
- molle rinforzate con bicchierini forati.

The Light Clutch have:

- reinforced basket
- specific cork disks
- reinforced springs with drilled caps.



25090502

FRIZIONE LIGHT CLUTCH 6 MOLLE
LIGHT CLUTCH 6 SPRINGS
125/150: VESPA PX - VNB - GT - LML - COSA

25090503

FRIZIONE LIGHT CLUTCH 7 MOLLE
LIGHT CLUTCH 7 SPRINGS
200: VESPA PX - RALLY - LML - COSA - T5



Dado speciale frizione | Special nut

Sostituisce il dado a castello originale
It replaces the original castle nut

25070102

DADO SPECIALE SPECIAL NUT
125/150/200: TUTTI I MODELLI ALL MODELS



Pinasco Clutch Slider

Il cuscinetto Pinasco Clutch Slider, ricavato dal pieno, ha la peculiarità di azzerare quel fastidioso problema della frizione che strappa in partenza o in cambiata.

The bearing Pinasco Clutch Slider, has the peculiarity to solve the annoying trouble of clutch ripping during in departing or in changing gear.

25091800

CLUTCH SLIDER CLUTCH SLIDER
125/150/200: VESPA PX - GT - LML - RALLY - COSA - T5

25090828

MOLLE RINFORZATE
SPRING FORCE

125/150: VNB - VBB - GL - GT - GTR
SPRINT - SPRINTV. PX - LML - COSA
200: VESPA PX - PE - RALLY
LML - COSA - T5



Molle rinforzate | Spring Force

Il kit PINASCO SpringForce consente di eliminare dalle frizioni originali quel fastidioso pattinamento dei dischi in sughero che si verifica spesso dopo il potenziamento del motore e garantisce la perfetta tenuta anche su motori originali sottoposti a sforzi elevati durante lunghi viaggi con molti bagagli.

The kit PINASCO SpringForce allows to avoid the unpleasant slippery of cork disks that occurs with the original clutch components when the engine is tuned. The kit ensures a perfect performance also with original engines in case of oversteering or long trips or over loading.

Dischi + kit 6/7 molle Cork disks + 6/7 springs kit

Il kit è composto da dischi in sughero e acciaio, molle rinforzate e bicchierini forati

The kit have specific cork disks, reinforced springs with drilled caps.

25090604

DISCHI + KIT 6 MOLLE
CORK DISKS + 6 REINFORCED SPRINGS
125/150: VNB - VBB - GL - GT - GTR
SPRINT - SPRINTV. PX - LML - COSA

25090604

DISCHI + KIT 7 MOLLE
CORK DISKS + 7 REINFORCED SPRINGS
200: VESPA PX - PE - RALLY
LML - COSA - T5



Ingranaggi specifici per Vespa Large Frame Pinasco Gears for Vespa Large Frame

Dai famosi FOUR DRIVE per Vespa PX prima serie nasce una nuova generazione di ingranaggi specifici per Vespa. Ingranaggi di trasmissione a denti dritti rasati con rapporto calcolato per motori elaborati. Realizzati in acciaio cementato, rettificato e temprato, sono estremamente resistenti e silenziosi.

From the famous FOUR DRIVE for Vespa PX first series comes a new generation of specific gears for Vespa. Transmission gears with trimmed straight teeth and ratio for modified engines. Made from casehardened, ground and hardened steel, they are extremely resistant and silent in operation.

INGRANAGGI CAMBIO VESPA SMALL VESPA SMALL GEARS

- 25270900** CAMBIO VESPA SMALL Z 10-14-18-21 "GRAN TURISMO" (4[^] CORTA)
GEAR VESPA SMALL Z 10-14-18-21 "GRAN TURISMO" (4[^] SHORT)
- 25270901** CAMBIO VESPA SMALL Z 10-14-17-20 "GRAN SPORT" (3[^] CORTA, 4[^] CORTISSIMA)
GEAR VESPA SMALL Z 10-14-17-20 "GRAN SPORT" (3[^] SHORT, 4[^] VERY SHORT)
- 25270902** CAMBIO VESPA SMALL Z 10-14-18-20 "GRAN SPORT"
GEAR VESPA SMALL Z 10-14-18-20 "GRAN SPORT"



INGRANAGGIO GEAR

Si monta in pochi minuti, senza alcuna modifica sulla campana originale. E' sufficiente rimuovere lo sportello di accesso alla frizione e sostituire l'ingranaggio senza smontare la campana frizione. Aumenta la velocità massima di circa 10 km/h.

Suitable to the original clutch without modifications. It is only necessary to remove the clutch access cover and remove the gear without disassembling the clutch. Increases the max speed about 10 km/h.



25270972

INGRANAGGIO + 10KM/H
GEAR + 10KM/H
VESPA 50 SPECIAL 4M, APE 50



Old Style Scooter Racing Team & Pinasco
1^o Classificato 10h Endurance Scootentole Circuito Magny Cours 2013



INGRANAGGI CAMBIO VESPA LARGE VESPA LARGE GEARS

- 25270810** CAMBIO VESPA LARGE Z 12-13-17-20 "GRAN TURISMO"
GEAR VESPA LARGE Z 12-13-17-20 "GRAN TURISMO"
- 25270811** CAMBIO VESPA LARGE Z 12-13-16-20 "GRAN SPORT"
GEAR VESPA LARGE Z 12-13-16-20 "GRAN SPORT"
- 25270812** CAMBIO VESPA LARGE Z 12-13-16-19 "SUPER SPORT"
GEAR VESPA LARGE Z 12-13-16-19 "SUPER SPORT"

**PRIMARIA VESPA LARGE
VESPA LARGE GEARS**

- 25270816** PIGNONE VESPA LARGE Z 22 (6 MOLLE)
PINION VESPA LARGE Z 22 (6 SPRINGS)
- 25270817** PIGNONE VESPA LARGE Z 23 (6 MOLLE)
PINION VESPA LARGE Z 23 (6 SPRINGS)
- 25270819** PIGNONE VESPA LARGE Z 24 (7 MOLLE)
PINION VESPA LARGE Z 24 (7 SPRINGS)
- 25270823** CORONA VESPA LARGE Z 65
CORONA VESPA LARGE Z 65
- 25270824** CORONA VESPA LARGE Z 68
CORONA VESPA LARGE Z 68
- 25270829** KIT PRIMARIA VESPA LARGE Z 23/65 (6 SPRINGS)
PRIMARY DRIVE KIT VESPA LARGE Z 23/65 (6 SPRINGS)
- 25270832** KIT PRIMARIA VESPA LARGE Z 24/65 (7 MOLLE)
PRIMARY DRIVE KIT VESPA LARGE Z 24/65 (7 SPRINGS)

**PRIMARIA VESPA LARGE DENTI DRITTI
PRIMARY DRIVE VESPA LARGE STRAIGHT TEETH**

- 25270906** PIGNONE VESPA SMALL Z 23 INGRANA SU Z 72
PINION VESPA SMALL Z 23 ENGAGES ON Z 72
- 25270907** PIGNONE VESPA SMALL Z 24 INGRANA SU Z 72
PINION VESPA SMALL Z 24 ENGAGES ON Z 72
- 25270908** PIGNONE VESPA SMALL Z 25 INGRANA SU Z 72
PINION VESPA SMALL Z 25 ENGAGES ON Z 72
- 25270909** PIGNONE VESPA SMALL Z 26 INGRANA SU Z 69
PINION VESPA SMALL Z 26 ENGAGES ON Z 69
- 25270910** PIGNONE VESPA SMALL Z 27 INGRANA SU Z 69
PINION VESPA SMALL Z 27 ENGAGES ON Z 69
- 25270911** PIGNONE VESPA SMALL Z 28 INGRANA SU Z 69
PINION VESPA SMALL Z 28 ENGAGES ON Z 69
- 25270916** CORONA VESPA SMALL Z 69
CORONA VESPA SMALL Z 69
- 25270917** CORONA VESPA SMALL Z 72
CORONA VESPA SMALL Z 72

**PRIMARIA VESPA LARGE
VESPA LARGE GEARS**

- 25270926** PIGNONE VESPA LARGE Z 22 INGRANA SU Z64 (6 MOLLE) - DENTI DRITTI
PINION VESPA LARGE Z 22 ENGAGES ON Z64 (6 SPRINGS) - STRAIGHT TEETH
- 25270927** PIGNONE VESPA LARGE Z 22 INGRANA SU Z64 (7 MOLLE) - DENTI DRITTI
PINION VESPA LARGE Z 22 ENGAGES ON Z64 (7 SPRINGS) - STRAIGHT TEETH
- 25270928** KIT PRIMARIA VESPA LARGE Z 23/64 (6 MOLLE) - DENTI DRITTI
PRIMARY DRIVE KIT VESPA LARGE Z 23/64 (6 SPRINGS) - STRAIGHT TEETH
- 25270929** KIT PRIMARIA VESPA LARGE Z 23/64 (7 MOLLE) - DENTI DRITTI
PRIMARY DRIVE KIT VESPA LARGE Z 23/64 (7 SPRINGS) - STRAIGHT TEETH
- 25270930** KIT PRIMARIA VESPA LARGE Z 24/63 (7 MOLLE) - DENTI DRITTI
PRIMARY DRIVE KIT VESPA LARGE Z 24/63 (7 SPRINGS) - STRAIGHT TEETH

**CAMPANA FRIZIONE
"BLACK" VESPA SMALL
VESPA SMALL
CLUTCH BELL "BLACK"**

- 25270924** KIT PRIMARIA VESPA SMALL Z 24/72
PRIMARY DRIVE KIT VESPA SMALL Z 24/72
- 25270925** KIT PRIMARIA VESPA SMALL Z 27/69
PRIMARY DRIVE KIT VESPA SMALL Z 27/69



Kit Carburatori per Vespa Small Carburettor kits for Vespa Small

Kit carburatori da 16 a 24 mm per Vespa Small completi di collettore, manicotto, fascette e accessori per il corretto montaggio.

Carburettor kits from 16 to 24 mm for Vespa Small, supplied with intake manifold, clamps and fitmen.

- 25292700** IMPIANTO ALIMENTAZIONE VESPA PK-XL 3 FORI Ø 22 RIGIDO
CARBURETTOR KIT VESPA PK-XL 3 FORI Ø 22 W/CLAMP
- 25292701** IMPIANTO ALIMENTAZIONE VESPA PK-XL 3 FORI Ø 24 RIGIDO
CARBURETTOR KIT VESPA PK-XL 3 FORI Ø 24 W/CLAMP
- 25292707** IMPIANTO ALIMENTAZIONE VESPA SPECIAL/ET3 Ø 22 RIGIDO
CARBURETTOR KIT VESPA SPECIAL/ET3 Ø 22 W/CLAMP
- 25292708** IMPIANTO ALIMENTAZIONE VESPA SPECIAL/ET3 Ø 22 ELASTICO
CARBURETTOR KIT VESPA SPECIAL/ET3 Ø 22 W/RUBBER SLEEVE
- 25292715** IMPIANTO ALIMENTAZIONE VESPA SPECIAL/ET3 Ø 24 RIGIDO
CARBURETTOR KIT VESPA SPECIAL/ET3 Ø 24 W/CLAMP
- 25292716** IMPIANTO ALIMENTAZIONE VESPA SPECIAL/ET3 Ø 24 ELASTICO
CARBURETTOR KIT VESPA SPECIAL/ET3 Ø 24 W/RUBBER SLEEVE



Kit Carburatore | Carburettor Kit SHBC 16/16

- 25292764** VESPA 50 SPECIAL
- 25292912** VESPA 50 PK
- 25292914** VESPA 50 XL

Kit Carburatore | Carburettor Kit SHBC 19/19

- 25292773** VESPA 50/125 PRIMAVERA ET3
- 25292913** VESPA PK 50/125
- 25292915** VESPA PK XL 50/125



Carburatore | Carburettor SHBC 19/19

- 25290773** VESPA 50/125
- 25294894** APE 50/125 MIX

Carburatore | Carburettor SHBC 18/16P

- 25290958** APE 50 MIX



COLLETTORI ASPIRAZIONE PER VESPA SMALL INTAKE MANIFOLD FOR VESPA SMALL

- 25530306** COLLETTORE ASPIRAZIONE VESPA SPECIAL Ø 24 RIGIDO
INTAKE MANIFOLD VESPA SPECIAL Ø 24 W/CLAMP
- 25530307** COLLETTORE ASPIRAZIONE VESPA PK 3 FORI Ø 24 RIGIDO
INTAKE MANIFOLD VESPA PK 3 FORI Ø 24 W/CLAMP
- 25530954** COLLETTORE ASPIRAZIONE VESPA SPECIAL Ø 24 ELASTICO
INTAKE MANIFOLD VESPA SPECIAL Ø 24 W/RUBBER SLEEVE
- 25536947** MANICOTTO COMPLETO PHBL 20/22/24/25
COMPLETE RUBBER SLEEVE PHBL 20/22/24/25



- 25530300** COLLETTORE ASPIRAZIONE VESPA SPECIAL Ø16
INTAKE MANIFOLD VESPA SPECIAL Ø16
- 25530301** COLLETTORE ASPIRAZIONE VESPA SPECIAL Ø19
INTAKE MANIFOLD VESPA SPECIAL Ø19
- 25530955** COLLETTORE ASPIRAZIONE VESPA PK Ø16
INTAKE MANIFOLD VESPA PK Ø16
- 25530956** COLLETTORE ASPIRAZIONE VESPA PK Ø19
INTAKE MANIFOLD VESPA PK Ø19
- 25530957** COLLETTORE ASPIRAZIONE VESPA PK 3 FORI Ø 16
INTAKE MANIFOLD VESPA PK 3 HOLES Ø16
- 25530958** COLLETTORE ASPIRAZIONE VESPA PK 3 FORI Ø19
INTAKE MANIFOLD VESPA PK 3 HOLES Ø19



Kit Carburatori per Vespa Large Carburettor kits for Vespa Large

Kit carburatori da 28 e 30 mm, adatti a tutti gli scooter elaborati.
Vengono forniti con tutti gli accessori per il montaggio e già tarati per ogni Vespa.

*Carburettor kit 28-30 mm, suitable to all modified scooters.
Supplied with all mounting accessories and pre-calibrated for each Vespa.*

25292704

IMPIANTO ALIMENTAZIONE VESPA
CARBURETTOR KIT VESPA
PX 125-150-200
PHBH Ø28 Elastico / W/Rubber sleeve

25292705

IMPIANTO ALIMENTAZIONE VESPA
CARBURETTOR KIT VESPA
PX 125-150-200
PHBH Ø30 Elastico / W/Rubber sleeve



25292702

IMPIANTO ALIMENTAZIONE
VESPA PX 125-150-200 VHST Ø28 Elastico
CARBURETTOR KIT
VESPA PX 125-150-200 VHST Ø28 W/Rubber Sleeve



COLLETTORE ASPIRAZIONE VESPA LARGE INTAKE MANIFOLD VESPA LARGE

25530309

COLLETTORE ASPIRAZIONE VESPA PX 125-150-200
Ø28 / Ø30 ELASTICO
INTAKE MANIFOLD VESPA PX 125-150-200
Ø28 / Ø30 W/RUBBER SLEEVE



25536305

MANICOTTO COMPLETO PHBH Ø28 / Ø30
COMPLETE RUBBER SLEEVE PHBH Ø 28 / Ø 30



Carburatore VRX-R 24/26 Carburettor VRX-R 24/26

Carburatore VRX-R 24 e 26 con cornetto di aspirazione ricalcolato e ricavato dal pieno. Il carburatore Pinasco VRX-R è stato realizzato per ottimizzare le prestazioni dei classici carburatori Vespa che vengono lavorati a CNC e modificati per alloggiare il tromboncino in alluminio. La resa dei carburatori Pinasco VRX-R 24 e 26 è superiore soprattutto ai bassi regimi grazie all' "effetto Venturi" del cornetto che rende i motori più pronti fin dai bassi regimi.

Carburettor VRX-R 24 and VRX-R 26 with recalculated admission. The carburettor has been realized to optimize performances of the Classic Vespa's carburettor; is processed with CNC and modified to house the aluminum intake trumpet. The performance of Pinasco carburettors VRX-R 24 and 26 are strongly higher at the low RPM because of the "Venturi effect" of the intake trumpet.

25294912 CARBURATORE/CARBURETTOR VRX 20

25294913 CARBURATORE/CARBURETTOR VRX 20 MIX

25294999 CARBURATORE/CARBURETTOR VRX-R 22

25295000 CARBURATORE/CARBURETTOR VRX-R 22 MIX

25294802 CARBURATORE/CARBURETTOR VRX-R 24

25294803 CARBURATORE/CARBURETTOR VRX-R 24 MIX

25294902 CARBURATORE/CARBURETTOR VRX-R 26

25294903 CARBURATORE/CARBURETTOR VRX-R 26 MIX



25530448

CORNETTO ASPIRAZIONE
CARBURATORE
VESPA VRX 20 / VRX-R 22
AIR SYSTEM INTAKE
CARBURETTOR
VESPA VRX 20 / VRX-R 22
125/150: LML STAR 4T

25530450

CORNETTO ASPIRAZIONE
CARBURATORE
VESPA VRX 26 / VRX-R 24
AIR SYSTEM INTAKE
CARBURETTOR
VESPA VRX 26 / VRX-R 24
125/150: LML STAR 4T

25530449

CORNETTO ASPIRAZIONE
CARBURATORE
VESPA VRX-R 26
AIR SYSTEM INTAKE
CARBURETTOR
VESPA VRX-R 26
125/150: LML STAR 4T



Carburatore VNB-GT Carburettor VNB-GT

Carburatore specifico per Vespa a 2 travasi già tarato per il corretto funzionamento con tutti i cilindri in ghisa e alluminio Pinasco, vengono sostituiti gliollettina, polverizzatore e getti.

Specific carburettor for Vespa engine with 2 ports already set to work with all Pinasco aluminum or cast iron cylinders. Some internal components have been changed.

25294887

CARBURATORE VESPA 2 TRAVASI 20/20
CARBURETTOR VESPA 2 PORTS 20/20
125/150: VNB - VBB - GL - GT - GTR
SPRINT - SPRINT V.

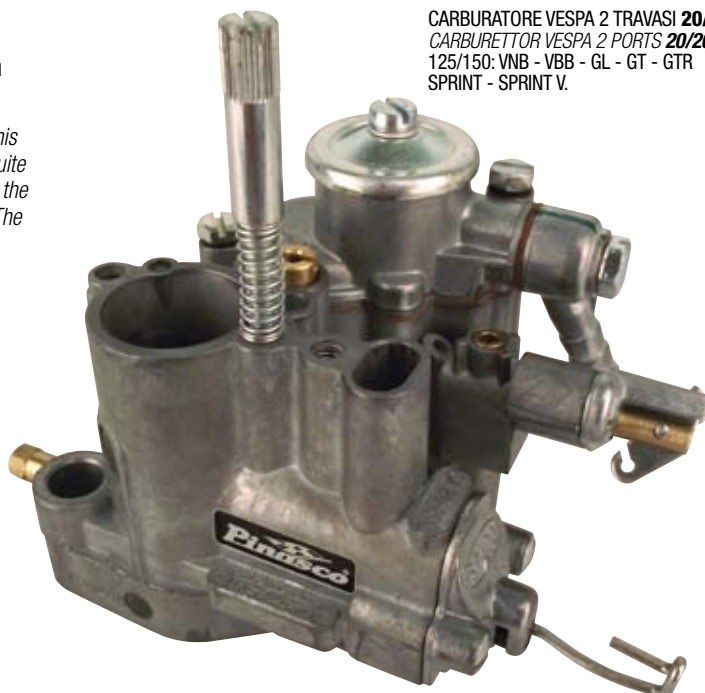

Kit Coperchio Carburatore SI Carburettor Cover Kit SI

Kit coperchio carburatore con passaggi benzina maggiorati e con spillo ammortizzato. Questo kit è stato studiato appositamente per ridurre il fastidioso svuotamento della vaschetta che si ha normalmente su elaborazioni con 177 cc in alluminio e ghisa e su 225 cc. Il kit riduce il rischio di scaldate o grippate e rende la guida più piacevole, è adattabile a tutti i carburatori Dell'Orto e Spaco.

Carburettor cover kit created to increase the passage of the fuel. This kit is studied to reduce the annoying emptying of the bowl that is quite frequent in tuned engines 177 cc and 225 cc. The kit reduces also the risk of seizing up the engine making your drive more comfortable. The kit is suitable for all Dell'Orto and Spaco carburettors.

25293102



Carburatore Pinasco **R** Pinasco Carburettor **R**

La serie speciale di carburatori Pinasco "R" è stata sviluppata per il mondo delle corse e per i preparatori più esigenti. Le modifiche apportate ai carburatori Pinasco "R" aumentano le prestazioni del carburatore e permettono una carburazione più efficiente e precisa. Tutti i carburatori Pinasco contrassegnati con la lettera "R" hanno i passaggi benzina interni lavorati a CNC che garantiscono il flusso ottimale di carburante ed eliminano l'effetto "vuoto benzina", anche il coperchio galleggiante viene interamente lavorato nei passaggi garantendo un perfetto riempimento della vaschetta. Nella serie SI 26/26 "R" il "Venturi" è stato ulteriormente lavorato per aumentare il diametro nominale e ottenere la dimensione massima di 26.00mm al posto della dimensione di 25.40mm della versione economica. Il carburatore "R", per quanto riguarda la serie SI, rappresenta il TOP di gamma ed è un'esclusiva Pinasco.

The special models of Pinasco carburetors "R" were developed for the world of racing and for the most demanding tuners. The changes made to the Pinasco carburetors "R" increase the performance and allow an efficient and accurate carburetion. All Pinasco carburetors marked with the letter "R" have the internal passages CNC machined to guarantee the right flow of fuel and to eliminate the effect of "empty gasoline", also the passages of the float chamber cover are completely machined to allow a perfect filling of the float chamber. On the models SI 26/26 "R", the "Venturi" has been further CNC machined to increase the standard diameter and get the maximum size of 26.00mm compared to 25.40mm of the cheap model. The carburetor "R", with regard to the SI models, is the TOP of the range and it is a Pinasco's sole model.

STANDARD

- 25294883** CARBURATORE VESPA 2 TRAVASI **20/15**
CARBURETTOR VESPA 2 PORTS **20/15**
125/150: VNB
- 25294884** CARBURATORE VESPA 2 TRAVASI **20/17**
CARBURETTOR VESPA 2 PORTS **20/17**
125/150: VBB - GL - GT - GTR - SPRINT - SPRINT V.
- 25294888** CARBURATORE / CARBURETTOR VESPA **20/20**
125/150: VESPA PX
- 25294889** CARBURATORE / CARBURETTOR VESPA **20/20 MIX**
125/150: VESPA PX - LML STAR 2T - COSA
- 25294891** CARBURATORE / CARBURETTOR VESPA PX **24/24**
125/150/200: VNB-VBB-GL-GT-GTR-SPRINT
SPRINT V.-PX-RALLY
- 25294890** CARBURATORE / CARBURETTOR VESPA PX **24/24 MIX**
125/150/200: PX - LML STAR 2T - COSA - RALLY
- 25294885** CARBURATORE / CARBURETTOR VESPA PX **26/26**
125/150/200: VNB-VBB-GL-GT-GTR-SPRINT
SPRINT V.-PX-RALLY
- 25294886** CARBURATORE / CARBURETTOR VESPA PX **26/26 MIX**
125/150/200: PX - LML STAR 2T - COSA - RALLY
- 25294900** CARBURATORE / CARBURETTOR VESPA T5 **24/24G**
- 25294901** CARBURATORE / CARBURETTOR VESPA T5 **24/24G MIX**
- 25294904** CARBURATORE / CARBURETTOR VESPA T5 **26/26G**
- 25294905** CARBURATORE / CARBURETTOR VESPA T5 **26/26G MIX**

RACING **R**

- 25294914** CARBURATORE / CARBURETTOR VESPA PX **22/22 ER**
- 25294915** CARBURATORE / CARBURETTOR VESPA PX **22/22 ER MIX**
- 25294906** CARBURATORE / CARBURETTOR VESPA PX **24/24 ER**
- 25294907** CARBURATORE / CARBURETTOR VESPA PX **24/24 ER MIX**
- 25294908** CARBURATORE / CARBURETTOR VESPA PX **26/26 ER**
- 25294909** CARBURATORE / CARBURETTOR VESPA PX **26/26 ER MIX**
- 25294910** CARBURATORE / CARBURETTOR VESPA T5 **26/26 GR**
- 25294911** CARBURATORE / CARBURETTOR VESPA T5 **26/26 GR MIX**

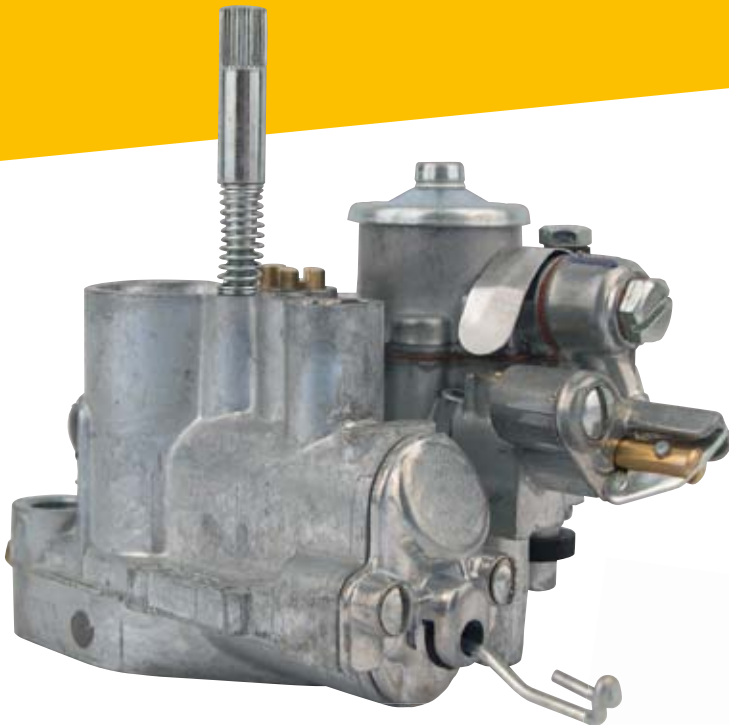
25295001

 CARBURATORE VESPA-COSA **26/26 H NUDO**
 CARBURETTOR VESPA-COSA **26/26 H NAKED**

25295002

 CARBURATORE VESPA-COSA **26/26 H COMPLETO**
 CARBURETTOR VESPA-COSA **26/26 H COMPLETE**

Marmitta Bianca Pinasco Pinasco White Exhaust

Per tutti gli appassionati Pinasco, per quelli che hanno ancora nel cuore i mitici anni 70-80, per tutti quelli che l'hanno sognata o l'hanno montata sulla loro prima Vespa, per chi ha vissuto gli anni ruggenti del vespismo italiano, Pinasco ripropone la mitica ed esclusiva Marmitta Bianca Siluro per tutte le Vespa 50-125 Small Frame con l'originale tubo di scarico a precamera ad espansione, brevetto Pinasco, che produce un "suono" inconfondibile. Il trattamento in ceramica è lo stesso dell'epoca, anche il logo è quello degli anni 70, proprio per dare all'appassionato vespista lo stesso prodotto che ha fatto sognare un'intera generazione. La smaltatura in ceramica bianca speciale è assolutamente inalterabile e resiste fino ad una temperatura di 800°, mentre con l'applicazione del marchio a fuoco avrete la garanzia di un prodotto che vi durerà in eterno.

To all Pinasco's fans, to the lovers of swinging 70s and 80s, to everybody who dreamed it or installed on their first Vespa, to who lived the roaring years of Italian Vespa, Pinasco offers again the mythical and exclusive White Exhaust for all Vespa small frame 50-125 with the original pre-chamber expansion, patented by Pinasco, that produces a special "sound". The ceramic treatment is the same as that time and the logo is that one used in the 70s as well to offer to all Vespa lovers the same product dreamed by a whole generation. The enamel, made of a special white ceramic, is extremely unalterable and it supports a temperature of 800° Celsius. The brand is hot printed to give you the warrantee of a product that will last forever.

25561795 MARMITTA BIANCA '79 CON RISONATORE
WHITE EXHAUST '79 WITH CHAMBER EXPANSION
50: SPECIAL

25561796 MARMITTA BIANCA '79 CON RISONATORE
WHITE EXHAUST '79 WITH CHAMBER EXPANSION
125: PRIMAVERA - ET3



25341795
RISONATORE VESPA 50
CHAMBER EXPANSION VESPA 50
50: SPECIAL

25341796
RISONATORE VESPA 125
CHAMBER EXPANSION VESPA 125
125: PRIMAVERA - ET3



Marmitta Pinasco "TOURING" per Vespa PX 125-150-200 Pinasco "TOURING" Muffler for Vespa PX 125-150-200

La marmitta PINASCO TOURING è stata concepita per esaltare le prestazioni del motore sia ai bassi che agli alti regimi mantenendo invariata la silenziosità. L'innovativo design che "esce da tutti gli attuali schemi" è stato studiato per ottenere la giusta espansione dei gas che permette di incrementare notevolmente le prestazioni del motore anche in allungo. La marmitta PINASCO TOURING è realizzata a mano da esperti artigiani ed è disponibile per Vespa PX 125-150-200.

The PINASCO TOURING muffler is designed to enhance the performance at both low and high speeds, keeping a low noise level. The innovative design that "comes out of all existing schemes" has been designed to get the gas expansion which allows a significant increasing of the performance even at high speed. The PINASCO TOURING muffler is handmade by skilled craftsmen and it's available for Vespa PX 125-150-200.



25560823

MARMITTA TOURING
TOURING EXHAUST
125/150: VESPA PX

25560824

MARMITTA TOURING
TOURING EXHAUST
200: VESPA PX

Marmitta Cromata Chromed Exhaust

Scarico sportivo Pinasco per tutte le Vespa 125-150-200, realizzato per il perfetto funzionamento su tutte le Vespa con motore originale o equipaggiate con i nostri kit di preparazione, viene assemblato a mano e cromato a spessore. Lo scarico sportivo Pinasco conferisce al motore un aumento di coppia e numero di giri, garantendo un notevole incremento di velocità. La cromatura rende questo accessorio non solo funzionale, ma anche esteticamente gradevole e apprezzato dagli amanti del tuning estetico.

Pinasco racing exhaust hand made and chrome plated for all Vespas 125-150-200, projected for a perfect utilization on all Vespas with original engine or with Pinasco engine. The exhaust increases the torque, the rpm of the engine and consequently increasing the speed of the vehicle. This accessory is not only functional but because of the chrome it is appreciated also from the lovers of aesthetic tuning.

125/150: VNB - VBB (RUOTE/WHEELS 8") **25560812**

125/150: GL - GT - GTR - SPRINT - SPRINT V. - TS **25560813**

125: VESPA T5 **25560814**

125/150: VESPA PX - LML STAR 2T - COSA **25560815**

200: VESPA PX - PE - RALLY **25560825**



Marmitta Symphony LML 4T Symphony LML 4T Exhaust

Pinasco Symphony è il primo scarico prestazionale, omologato, per scooter LML STAR 125-150-200 4T. Un prodotto performante e di lunga durata, frutto di innumerevoli prove al banco, saldato interamente a mano e realizzato in 2 modelli, il più economico in acciaio verniciato a polvere ed il più prestigioso in acciaio INOX. Con un ottimo silenziatore, ben curato, leggero e con ottime prestazioni, la marmitta Pinasco Symphony per LML 125-150 4T è munita di certificato di omologazione europea che permette la sostituzione dello scarico originale senza dover apportare modifiche alla carta di circolazione. Pinasco Symphony è un prodotto di altissima qualità e di pregio, con un sound eccezionale che saprà conquistare anche l'orecchio più fine.

Pinasco Symphony is the first performance exhaust for scooter LML STAR 125-150-200 4T. The exhaust has been tested for long time in different conditions to combine performance and reliability. It's handmade welded and supplied in two models: the cheapest is made of powder-coated steel, the most prestigious is made of INOX steel. The EU certificate of approval avoids the obligation to make any other kind of update of documents of your vehicle. Pinasco Symphony is a very high quality product with a perfect sound that will be loved by any ear.



VESPA

**25560821**

MARMITTA LML 4T INOX
INOX EXHAUST LML 4T
125/150: LML STAR 4T



LML 200

25560820

MARMITTA LML 4T NERA
BLACK EXHAUST LML 4T
125/150: LML STAR 4T

25560822

MARMITTA LML 4T NERA
BLACK EXHAUST LML 4T
200: LML STAR 4T



➤ Ammortizzatori Pinasco per Vespa Small / Large Pinasco Shock Absorbers for Vespa Small / Large

Gli ammortizzatori oleopneumatici PINASCO a doppio effetto rappresentano l'evoluzione tecnologica nel campo delle sospensioni regolabili rispettando le normative CE. Gli ammortizzatori PINASCO sono realizzati con materiale di altissima qualità MADE IN ITALY, ghiera di registrazione in alluminio ricavate dal pieno, supporto molla in acciaio lavorato a CNC e cromato, molla a doppio effetto calibrata in acciaio armonico. La forza di reazione di un ammortizzatore è data dalla resistenza che l'olio in esso contenuto incontra nel passaggio attraverso le valvole, costituite da fori calibrati e da otturatori a dischi precariati. La sospensione, tramite una ghiera di registro millimetrica, è in grado di precaricare la molla e di creare una taratura di compressione che varia in base alle esigenze del pilota. Gli ammortizzatori PINASCO sono il connubio perfetto tra sportività e piacere di guida e regalano al pilota emozioni uniche ad ogni curva garantendo il massimo della sicurezza sia in tenuta di strada che nelle frenate più brusche.

Pinasco double-action shock absorbers represent the technological developments in the field of adjustable suspension according to European standards. The Pinasco shock absorbers are MADE IN ITALY with the highest quality material, the adjusting rings are machined from solid, steel spring support are machined CNC and chrome-plated, double action springs are made of calibrated steel. The reaction force of a shock absorber is given by the resistance that the oil contained in it encounters when passing through the valves, consisting of calibrated holes and discs. With an adjusting millimetric ring the suspension is able to preload the spring and to create a calibration compression which changes according to the needs of the driver. The shock absorbers are the perfect combination of sportiness and driving pleasure, they give unbelievable driving emotions and maximum safety.

25441002

AMMORTIZZATORE PINASCO POSTERIORE
REAR SHOCK ABSORBERS

VESPA (TUTTI I MODELLI 1960-2012 / ALL MODELS 1960-2012)

25441002

AMMORTIZZATORE PINASCO ANTERIORE
FRONT SHOCK ABSORBERS

VESPA PX 125/150/200 - T5



25441007

AMMORTIZZATORE ANTERIORE
FRONT SHOCK ABSORBER
VESPA 50/125 PK XL - RUSH

25441004

AMMORTIZZATORE ANTERIORE
FRONT SHOCK ABSORBER
VESPA 50 - PRIMAVERA - ET3 -PK



Carter motore Pinasco MASTER 125-150cc **Pinasco MASTER Crankcase 125-150cc**

Realizzato in pressofusione, il nuovo carter motore Pinasco per Vespa Large è la punta di diamante della produzione, notevoli sono le migliorie apportate al modello originale, tra le quali:

- Cuscinetto lato volano maggiorato
- Riporti di materiale in corrispondenza dei travasi
- Valvola di aspirazione maggiorata
- Rinforzi nei punti critici

Nel modello 125-150cc il carter è stato lavorato per ospitare l'albero del modello 200, aumentando la dimensione della valvola ed utilizzando una biella da 110mm.

The new die-casted crankcase for Pinasco Vespa Large is the spearhead of our production, there are many improvements comparing to the original model, including:

- *Big bearing on flywheel side*
- *Extra material to work the ports*
- *Big Valve Intake*
- *Critical points have been reinforced*

On the model 125-150cc, the crankcase has been worked to accommodate the crankshaft of the model 200, increasing the size of the valve and using a connecting rod 110mm.

**NUOVO
NEW**

25482020

CARTER MOTORE COMPLETO "MASTER"
"MASTER" CRANKCASE
VESPA PX 125-150

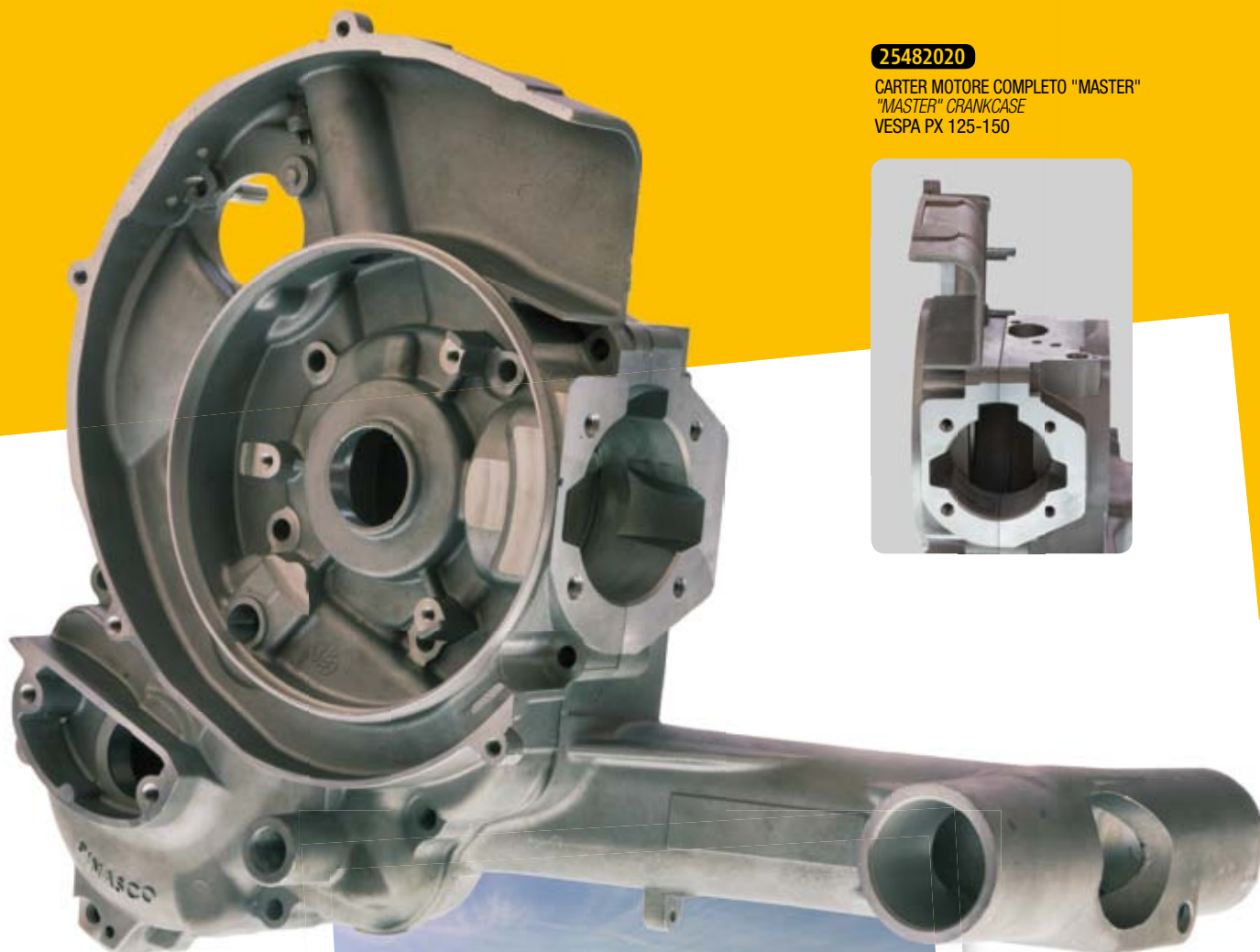

Carter motore Pinasco MASTER 200cc Pinasco MASTER Crankcase 200cc

25482021

CARTER MOTORE COMPLETO "MASTER"
"MASTER" CRANKCASE
VESPA PX 200

**NUOVO
NEW**

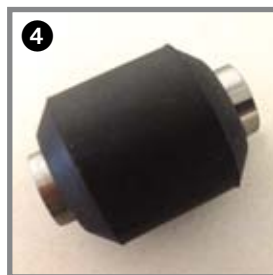
**1****2****3****4****COMPONENTI INCLUSI NELLA CONFEZIONE**

- Carter motore (1)
- Serie prigionieri (2)
- Coppia silentblock motore (3)
- Silentblock ammortizzatore posteriore (4)

COMPONENTS INCLUDED IN THE PACKAGE

- Crankcase (1)
- Screws Set (2)
- Pair of Engine Silentblock (3)
- Rear Shock Silentblock (4)

CODICE	APPLICAZIONE	SILENTBLOCK BRACCIO MOTORE	KIT PRIGIONIERI	SERIE CUSCINETTI DI BANCO	SILENTBLOCK AMM. POST.
ITEM	APPLICATION	ENGINE ARM SILENTBLOCK	SCREWS & BOLT SET	CRANKSHAFT BEARING SET	REAR SHOCK SILENTBLOCK
25482020	VESPA LARGE 125/150	25482400	25482500	25412903	25482401
25482021	VESPA LARGE 200	25482400	25482501	25412903	25482401

Testa VRH 215-225-235 cc VRH Cylinder Head 215-225-235 cc

La testa Pinasco VRH, rispetto al modello corsa corta, ha la camera di scoppio ampliata e lavorata a CNC con banda di squish ridotta ed altezza diminuita, il rapporto di compressione raggiunto è di 11:1. Test al banco hanno mostrato un incremento di potenza di 1,5CV e di 1,8Nm di coppia massima.

"Pinasco VRH" head, compared with the short-stroke model, has the combustion chamber CNC machined and a reduced/decreased squish band, the compression ratio is 11:1. Dyno tests showed a power increase of 1.5 hp and 1.8 Nm of torque.



25243609

TESTA VRH PER VESPA 200 Ø 69
CORSA LUNGA 60mm
VRH CYLINDER HEAD
FOR VESPA 200 Ø 69
LONG STROKE 60mm
200: VESPA PX - PE - RALLY - COSA



Testa VRH Candela Centrale VRH Cylinder Head - Central Spark Plug

La testa Pinasco VRH, rispetto al modello corsa corta, ha la camera di scoppio ampliata e lavorata a CNC con banda di squish ridotta ed altezza diminuita, il rapporto di compressione raggiunto è di 11:1. Test al banco hanno mostrato un incremento di potenza di 1,5CV e di 1,8Nm di coppia massima.

"Pinasco VRH" head, compared with the short-stroke model, has the combustion chamber CNC machined and a reduced/decreased squish band, the compression ratio is 11:1. Dyno tests showed a power increase of 1.5 hp and 1.8 Nm of torque.



25243611

TESTA VRH PER VESPA 200 Ø 69
CANDELA CENTRALE
CORSA LUNGA 60mm
VRH CYLINDER HEAD
CENTRAL SPARK PLUG
FOR VESPA 200 Ø 69
LONG STROKE 60mm
200: VESPA PX - PE - RALLY - COSA

25243610

TESTA VRH PER VESPA 200 Ø 69
CANDELA CENTRALE **CORSA 57mm**
VRH CYLINDER HEAD
CENTRAL SPARK PLUG
FOR VESPA 200 Ø 69 **STROKE 57mm**
200: VESPA PX - PE - RALLY - COSA



Testa VRH Candela Centrale VRH Cylinder Head Central Spark

Testa VRH candela centrale dedicata a tutte le Vespa equipaggiate con gruppi termici Pinasco o qualunque altro gruppo termico 177. La nuova testa VRH a candela centrale, infatti, è l'unica adattabile a tutti i gruppi termici presenti sul mercato, perché mantiene la classica forma delle teste più comuni. La testa VRH è innovativa e viene prodotta in 2 modelli differenti, il modello base VRH PRO a candela centrale con camera di scoppio e squish ricalcolato e la più prestigiosa scomponibile VRH GP composta da un porta-testa e 2 testine; la prima testina denominata GP1 dedicata al turismo con camera emisferica e squish ricalcolato, la seconda denominata GP2 con l'innovativo disegno a cilindro raggiato dedicata al mondo delle corse con rapporto di compressione maggiorato e banda di squish più spinta. La testa VRH GP è destinata al preparatore più esigente, grazie alle cupole scomponibili può essere modificata a piacere realizzando qualunque tipo di disegno e rapporto di compressione finalizzati al massimo rendimento del proprio motore. Vengono forniti su ordinazione i semilavorati e lo strumento apposito per bloccare la testina sul tornio e facilitare tutte le fasi di realizzazione.

VRH head with central spark dedicated to all Vespa equipped with Pinasco cylinder kit or any other kit 177cc. This head is the only central spark head suitable with all cylinder kits available on the market because it maintains the classical shape of the most common heads. The VRH head is produced in two models: the base model VRH PRO with combustion chamber and squish recalculated and the more prestigious modular VRH GP made of a head holder and two small heads: the first called GP1 dedicated to tourism with semi spherical combustion chamber and recalculated squish, the second called GP2 with a very innovative design specific for racing increased compression ratio and more stressed squish. The VRH GP is dedicated to the most exigent tuner; it may be modified realizing any design and compression ratio to obtain the maximum performances from an engine. You can also order the half-processed with a specific tool to block the small head on the lathe to make easier the realization of the personalized head.



VRH GP

25243710

TESTA VRH GP CANDELA CENTRALE SCOMPONIBILE
MODULAR VRH GP CYLINDER HEAD
CENTRAL SPARK PLUG
125/150: VNB - VBB - GL - GT - GTR - SPRINT
SPRINT V. - PX - LML STAR 2T - COSA

25243715

TESTINA GP GREZZO
HALF PROCESSED HEAD
125/150: VNB - VBB - GL - GT - GTR - SPRINT
SPRINT V. - PX - LML STAR 2T - COSA



25243716

TESTINA GP1 EMISFERICA
HEAD GP1 SEMISPHERICAL
125/150: VNB - VBB - GL - GT - GTR - SPRINT
SPRINT V. - PX - LML STAR 2T - COSA



25243717

TESTINA GP2 RACING
HEAD GP2 RACING DESIGN
125/150: VNB - VBB - GL - GT - GTR - SPRINT
SPRINT V. - PX - LML STAR 2T - COSA



VRH PRO

25243700

TESTA VRH CANDELA CENTRALE
VRH CYLINDER HEAD CENTRAL SPARK PLUG
125/150: VNB - VBB - GL - GT - GTR - SPRINT
SPRINT V. - PX - LML STAR 2T - COSA



VRX PRO CL

25243701

TESTA VRH CANDELA CENTRALE CORSA LUNGA
VRH CYLINDER HEAD CENTRAL SPARK PLUG LONG STROKE
125/150: VNB - VBB - GL - GT - GTR - SPRINT
SPRINT V. - PX - LML STAR 2T - COSA

Kit Cuscinetti di Banco Alta Velocità High Speed Bench Bearings Kit

Cuscinetti di banco Alta Velocità per Vespa Small e Vespa Large, con gabbie in poliammide o bachelite, che sostituiscono quelle in ferro in modo da ridurre notevolmente gli attriti di rotolamento delle sfere, permettere al motore di aumentare il numero di giri e la durata, migliorare fluidità e silenziosità di funzionamento. I Cuscinetti di Banco Alta Velocità Pinasco sono intercambiabili agli originali Vespa.

High speed bench bearings for Vespa Small and Vespa Large, with polyamide or bakelite cages, which replace iron to reduce the friction and allow the engine to increase the number of rpm and improving durability, fluidity and noise. The Pinasco High Speed bench bearings are interchangeable to the original Vespa ones.

- 25412900** PINASCO KIT CUSCINETTI DI BANCO VESPA PX 125-150-200
PINASCO CRANKCHASE BEARING KIT VESPA PX 125-150-200
- 25412901** PINASCO KIT CUSCINETTI DI BANCO VESPA LARGE 1953 » 1972
PINASCO CRANKCHASE BEARING KIT VESPA LARGE 1953 » 1972
- 25412902** PINASCO KIT CUSCINETTI DI BANCO VESPA 50 - ET3
PINASCO CRANKCHASE BEARING KIT VESPA 50 - ET3
- 25412903** PINASCO KIT CUSCINETTI DI BANCO VESPA T5 - RALLY 180
RALLY 200 FEMSA - GS 160 - SS 180
PINASCO CRANKCHASE BEARING KIT VESPA T5 - RALLY 180
RALLY 200 FEMSA - GS 160 - SS 180
- 25413010** CUSCINETTO PINASCO LATO FRIZIONE VESPA LARGE 25X62X12
PINASCO BEARING CLUTCH SIDE VESPA LARGE 25X62X12
- 25413011** CUSCINETTO PINASCO LATO VOLANO VESPA PX-PE 25X38X15
PINASCO BEARING FLYWHEEL SIDE VESPA PX-PE 25X38X15
- 25413012** CUSCINETTO PINASCO LATO VOLANO VESPA 50-ET3 20X47X14
PINASCO BEARING FLYWHEEL SIDE VESPA 50-ET3 20X47X14
- 25413013** CUSCINETTO PINASCO LATO FRIZIONE VESPA 50-ET3 17X47X14
PINASCO BEARING CLUTCH SIDE VESPA 50-ET3 17X47X14
- 25413014** CUSCINETTO PINASCO LATO FRIZIONE VESPA T5 RALLY 180
RALLY 200 FEMSA - GS 160 - SS 180 25X52X15
PINASCO BEARING CLUTCH SIDE VESPA T5 RALLY 180
RALLY 200 FEMSA - GS 160 - SS 180 25X52X15



Lubrificanti | Lubricants

HRG Olio sintetico per cambio Vespa 2T con frizione a bagno d'olio

Il primo olio Full Synt studiato esclusivamente per il cambio Vespa 2T, garantisce innesti morbidi e precisi, preserva gli ingranaggi dall'usura e allunga la vita dei dischi frizione. Le ottime caratteristiche viscosimetriche evitano l'incollaggio dei dischi a freddo e l'usura degli ingranaggi a caldo.

HRG Fully synthetic lubricant for Vespa 2 stroke gear box with wet clutch

First oil Full Synt for Vespa gearbox, ensures smooth and precise engagement, preserves gears from wear, extends clutch plates life. Latest generation additives avoid discs bonding and gears wear.

Runner VT Olio Miscela Base Sintetica per Vespa e ciclomotori 2 Tempi

Formulazione base sintetica con polimeri antigrippaggio studiata esclusivamente per motori Vespa e ciclomotori 2 tempi con o senza miscelazione separata. Garantisce una combustione ottimale anche nelle condizioni più gravose. Mantiene puliti i segmenti ed i pistoni. Protegge anche a motore freddo. Evita l'accumulo dei residui carboniosi in camera di combustione. Elimina i depositi nello scarico.

Runner VT Semi Synt Oil mixture for Vespa & mopeds 2 Stroke

Formulation synthetic with anti seizure polymers designed exclusively for Vespa and mopeds 2 stroke engines with or without separate mixing. Ensures optimal combustion even in the toughest conditions. Keeps clean the piston rings and the piston. Protects even with a cold engine. Prevents the accumulation of carbon deposits in the combustion chamber. Removes all deposits in the exhaust.



25251000

OLIO MISCELA VESPA
PINASCO RUNNER VT
LUBRICANT PINASCO RUNNER VT
FOR VESPA & MOPEDS 2 STROKE

25251010

CONFEZIONE DA 12 Pz
OLIO MISCELA VESPA
PINASCO RUNNER VT
12 TANK LUBRICANT
PINASCO RUNNER VT
FOR VESPA & MOPEDS 2 STROKE



25251001

OLIO CAMBIO VESPA
PINASCO HRG
LUBRICANT PINASCO HRG
FOR STROKE GEAR BOX

25251011

CONFEZIONE DA 12
OLIO CAMBIO VESPA
PINASCO HRG
12 TANK LUBRICANT
PINASCO HRG
FOR STROKE GEAR BOX

Pneumatici Pista Track Tires

Pneumatici slick e rain esclusivamente destinati all'uso in pista con mescole specifiche per ogni tipo di impiego.

Slick and rain tires for an exclusively track use with specific compound for any kind of need.

10461001 PNEUMATICO/TIRE RACING 90/90R10" SOFT

10461002 PNEUMATICO/TIRE RACING 90/90R10" MEDIUM

10461008 PNEUMATICO/TIRE RACING 90/90R10" RAIN

10461011 PNEUMATICO/TIRE RACING 100/85R10" SOFT

10461012 PNEUMATICO/TIRE RACING 100/85R10" MEDIUM

10461018 PNEUMATICO/TIRE RACING 100/85R10" RAIN



Disco Graduato Degree-Wheel

Fondamentale per tutti gli esperti in elaborazioni e non, questo disco graduato permette la lettura con precisione dei gradi di apertura delle luci di scarico e di ammissione nel cilindro, la conoscenza di tali valori e' indispensabile per la corretta messa a punto del motore.

This graduated disk is very important for all people who want to tune an engine. The disk allows to read with precision the times of opening of transfer ports and exhaust port. It is very important to have this data for a correct set up of the engine

10070830



Kit Carburazione Carburettor Kits

I Kit Carburazione Pinasco sono realizzati per semplificare il setting dei carburatori SI e contengono tutta la serie di getti pulverizzatori e freni aria necessari per realizzare una corretta carburazione.

Pinasco carburetion kit realized to simplify the setting of SI carburetors including all accessories to make a correct carburetion.



- 25293000** KIT CARBURAZIONE PINASCO 177CC
CARBURETION KIT PINASCO 177CC
- 25293001** KIT CARBURAZIONE PINASCO 215-225CC
CARBURETION KIT PINASCO 215-225CC
- 25293002** KIT CARBURAZIONE PINASCO SI 20-20 EURO 1-2-3 177CC
CARBURETION KIT PINASCO SI 20-20 EURO 1-2-3 177CC
- 25293100** KIT POLVERIZZATORI CARBURATORE SI
DIFFUSER KIT FOR CARBURETTOR SI
- 25293101** KIT CALIBRATORI CARBURATORE SI
GAUGE KIT FOR CARBURETTOR SI
- 25293103** KIT GETTI MAX SI 4576 (100-102-104-106-108)
JETS KIT MAX SI 4576 (100-102-104-106-108)
- 25293104** KIT GETTI MAX SI 4576 (110-112-115-118-120)
JETS KIT MAX SI 4576 (110-112-115-118-120)
- 25293105** KIT GETTI MAX SI 4576 (122-125-128-130-132)
JETS KIT MAX SI 4576 (122-125-128-130-132)
- 25293106** KIT GETTI MAX SI 4576 (135-138-140-142-145)
JETS KIT MAX SI 4576 (135-138-140-142-145)
- 25293107** KIT GETTI MAX SI 4576 (148-150-155-160-165)
JETS KIT MAX SI 4576 (148-150-155-160-165)
- 25293108** KIT GETTI MINIMO SI 9892 (58-60-62-65-68/160)
JETS KIT MINIMUM SI 9892 (58-60-62-65-68/160)

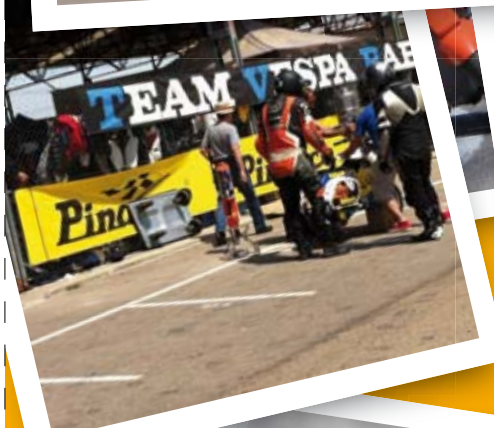

Gruppo termico ZUERA per Vespa Small Cylinder Kit ZUERA for Vespa Small

Sviluppato sui campi di gara, il gruppo termico "Zuera" si presta ad essere utilizzato anche per l'uso turistico, i diagrammi di scarico e di aspirazione sono stati studiati per avere il giusto compromesso tra coppia massima e potenza massima, permettendo al motore di "spingere" in qualunque condizione di esercizio senza buchi di erogazione e mancamenti. La testa a candela centrale ad 8 prigionieri garantisce il massimo delle prestazioni ed impedisce la deformazione dei piani di tenuta. Il nuovo gruppo termico "Zuera" 135cc è eccezionale sia nell'uso quotidiano che in quello agonistico.

Developed on the track, the cylinder kit "Zuera" can be used for touring, exhaust and intake diagrams are designed to get the right balance between maximum torque and maximum power, allowing the engine to "push" in any situation without any default. The central spark plug head at 8 holes ensures maximum performance and prevents deformation of the sealing surfaces. The new cylinder "Zuera" 135cc is superb, both in daily and racing use.

26031800

GRUPPO TERMICO 135CC
IN ALLUMINIO
ASPIRATO AL CARTER
ALUMINIUM CYLINDER KIT 135CC
CRANKCASE INTAKE



26031801

GRUPPO TERMICO 135CC
IN ALLUMINIO
ASPIRATO AL CILINDRO
ALUMINIUM CYLINDER KIT 135CC
CYLINDER INTAKE



CODICE ITEM	PRODOTTO PRODUCT
25381102	COLLETTORE LAMELLARE COMPLETO COMPLETE INTAKE MANIFOLD
25381300	PACCO LAMELLARE VALVE PACK
25381400	GUIDAFLUSSI FLOW GUIDE
25387300	KIT LAMELLE REED KIT
25536802	COLLETTORE ASPIRAZIONE INTAKE MANIFOLD
25536305	MANICOTTO IN GOMMA COMPLETO COMPLETE RUBBER SLEEVE

CODICE ITEM	APPLICAZIONE APPLICATION	Ø / N° SEGMENTI Ø / N° RINGS	PISTONE COMPLETO PISTON KIT	SEGMENTO PISTON RING	TESTA "VRH" 8P HEAD "VRH" 85P	SERIE GUARNIZIONI GASKET SET
26031800	PIAGGIO VESPA 125 ET3-PK / ALLUMINIO / CC / BIG BORE	57,5/1	25121012	25113450	25243615	25332204
26031801	PIAGGIO VESPA 125 ET3-PK / ALLUMINIO / CC / LAMELLARE / BIG BORE	57,5/1	25121012	25113450	25243615	25332204

Gruppi termici Vespa "RACING" 177-190cc Cylinder Kits Vespa "RACING" 177-190cc

La serie di gruppi termici "RACING" è una serie speciale realizzata da Pinasco, principalmente per le competizioni, che differisce dalla serie "TUNING" per le prestazioni notevolmente superiori e che soddisferà anche il preparatore più esigente.

The "RACING" cylinder kit series is a special development by Pinasco, mostly for racing use, which differs from the "TUNING" series for high performance to satisfy even the most demanding engine tuners.



26031930

GRUPPO TERMICO
IN ALLUMINIO
"VESPONE RR"
TRAVERSINO 177CC
ALUMINIUM CYLINDER KIT
"VESPONE RR"
TRAVERSINO 177CC



25121110

PISTONE DUE SEGMENTI
PISTON TWO RINGS



26031931

GRUPPO TERMICO IN ALLUMINIO
"VESPONE RB" BOOSTER 177CC
ALUMINIUM CYLINDER KIT
"VESPONE RB" BOOSTER 177CC

26032931

GRUPPO TERMICO IN ALLUMINIO
"VESPONE RX" BOOSTER 190CC
ALUMINIUM CYLINDER KIT
"VESPONE RX" BOOSTER 190CC

CODICE	APPLICAZIONE	Ø / N° SEGMENTI	PISTONE COMPLETO	SEGMENTO	SERIE SEGMENTI	TESTA	S/GUARNIZIONI
ITEM	APPLICATION	Ø / N° RINGS	PISTON KIT	PISTON RING	RING SET	HEAD	GASKET SET
26031930	PIAGGIO VESPA PX 177 / "VESPONE RR" / RACING TRAVERSINO (CORSA 57)	63/1 - GFT	25121064	25113451	-	25243700	25331669
	OPTIONAL TUNING	63/2 - GFT	25121110	-	25173476		
26031931	PIAGGIO VESPA PX 177 / "VESPONE RB" / RACING BOOSTER (CORSA 57)	63/1 - GFT	25121064	25113451	-	25243700	25331669
	OPTIONAL TUNING	63/2 - GFT	25121110	-	25173476		
26032931	PIAGGIO VESPA PX 190 / "VESPONE RX" / RACING BOOSTER (CORSA 60)	63/1 - GFT	25121064	25113451	-	25243701	25331669
	OPTIONAL TUNING	63/2 - GFT	25121110	-	25173476		

Optional Tuning = Componenti Tuning / Performance Spares



25125506

PISTONE DUE SEGMENTI
PISTON TWO RINGS



26031900

GRUPPO TERMICO
IN ALLUMINIO
"RACE 9TS" 8P 215CC
ALUMINIUM CYLINDER KIT
"RACE 9TS" 8P 215CC

26032900

GRUPPO TERMICO
IN ALLUMINIO "RACE 9TX" 8P
CORSA LUNGA 225CC
ALUMINIUM CYLINDER KIT
"RACE 9TX" 8P LONG STROKE 225CC

26031901

GRUPPO TERMICO
IN ALLUMINIO
"884 RS" 8P 215CC
ALUMINIUM CYLINDER KIT
"884 RS" 8P 215CC

26032901

GRUPPO TERMICO
IN ALLUMINIO "884 RX" 8P
CORSA LUNGA 225CC
ALUMINIUM CYLINDER KIT
"884 RX" 8P
LONG STROKE 225CC



CODICE ITEM	PRODOTTO PRODUCT
25381101	COLLETTORE LAMELLARE COMPLETO COMPLETE INTAKE MANIFOLD
25381301	PACCO LAMELLARE VALVE PACK
25387301	KIT LAMELLE REED KIT
25536801	COLLETTORE ASPIRAZIONE INTAKE MANIFOLD

25125508

PISTONE UN SEGMENTO
PISTON ONE RING



25290785

CARBURATORE
SHBT 19.19D
CARBURETTOR
SHBT 19.19D

CODICE ITEM	APPLICAZIONE APPLICATION	Ø / N° SEGMENTI Ø / N° RINGS	PISTONE COMPLETO PISTON KIT	SEGMENTO PISTON RING	SERIE SEGMENTI RING SET	TESTA "VRH" 8P HEAD "VRH" 8P	SERIE GUARNIZIONI GASKET SET
26031900	PIAGGIO VESPA PX 215 / "RACE 9TS" / 8P (CORSA 57)	69/1	25125508	25113452	-	25243610	25331654
	OPTIONAL TUNING	69/2	25125506	-	25173427		
26031901	PIAGGIO VESPA PX 215 / "884 RS" / 8P / DOPPIA ALIMENTAZIONE (CORSA 57)	69/2	25125506	-	25173427	25243610	25332202
	OPTIONAL TUNING	69/1	25125508	25113452	-		
26032900	PIAGGIO VESPA PX 225 / "RACE 9TX" / 8P (CORSA 60)	69/1	25125508	25113452	-	25243611	25331654
	OPTIONAL TUNING	69/2	25125506	-	25173427		
26032901	PIAGGIO VESPA PX 225 / "884 RX" / 8P / DOPPIA ALIMENTAZIONE (CORSA 60)	69/2	25125506	-	25173427	25243611	25332202
	OPTIONAL TUNING	69/1	25125508	25113452	-		

Optional Tuning = Componenti Tuning / Performance Spares

Alberi Motore Vespa Small "Competizione" Crankshafts Vespa Small "Competizione"

Gamma di alberi motore estremamente performanti, dedicati al turismo veloce ed alle competizioni. Gli alberi motore PINASCO COMPETIZIONE si affiancano alla produzione classica e differiscono per:

- grado di aspirazione più spinto
- nuova fluidodinamica del taglio aspirante
- nuova sbilanciatura racing ottenuta con inserti in tungsteno
- innovativi intarsi in Teflon per aumentare la pressione interna dei carter fin dai minimi regimi

L'albero motore PINASCO COMPETIZIONE incrementa notevolmente la potenza e la coppia massima fin dai bassi regimi, il numero di giri di rotazione del motore aumenta migliorando le prestazioni complessive.

High performance crankshafts for racing and fast tourism use. The PINASCO "COMPETIZIONE" crankshafts add themselves to the classic range and differ in:

- Racing intake degrees
- New fluid dynamics of the cutting surface
- New racing balancing got by tungsten inserts

The PINASCO "COMPETIZIONE" crankshafts increase the power at low speed and torque even the maximum rpm of the engine by increasing the full performance.

26081889

ALBERO MOTORE "COMPETIZIONE"
VESPA SMALL 125 MASSE PIENE Ø20
CRANKSHAFT "COMPETIZIONE"
VESPA SMALL 125 FULL MASS Ø20



26081888

ALBERO MOTORE "COMPETIZIONE"
VESPA SMALL 125 ANTICIPATO Ø20
CRANKSHAFT "COMPETIZIONE"
VESPA SMALL 125 ADVANCED Ø20



▲
Vista lato volano
Flywheel side view

▲
Vista lato frizione
Clutch side view

26081887

ALBERO MOTORE "COMPETIZIONE"
VESPA PX 125-150 CORSA ORIGINALE 57mm
CRANKSHAFT "COMPETIZIONE"
VESPA PX 125-150 ORIGINAL STROKE 57mm

26081886

ALBERO MOTORE "COMPETIZIONE"
VESPA PE 213 CORSA ORIGINALE 57mm
CRANKSHAFT "COMPETIZIONE"
VESPA PE 213 ORIGINAL STROKE 57mm

26081826

ALBERO MOTORE "COMPETIZIONE"
VESPA PX 177 **CORSA LUNGA 60mm**
CRANKSHAFT "COMPETIZIONE"
VESPA PX 177 **LONG STROKE 60mm**

26081827

ALBERO MOTORE "COMPETIZIONE"
VESPA PE 225 **CORSA LUNGA 60mm**
CRANKSHAFT "COMPETIZIONE"
VESPA PE 225 **LONG STROKE 60mm**

**26081829**

ALBERO MOTORE "COMPETIZIONE"
VESPA PX 235 **CORSA LUNGA 62mm**
CRANKSHAFT "COMPETIZIONE"
VESPA PX 235 **LONG STROKE 62mm**



Kit Trasformazione Corsa Lunga 190-225cc Tuning Kit Long Stroke 190-225cc

Il perfetto abbinamento tra gruppo termico ed albero motore per la trasformazione corsa lunga della Vespa 125-150-200. Entrambi i componenti sono stati sviluppati e testati, insieme, al banco prova ed in pista.

The perfect combination between cylinder kit and crankshaft for a long-stroke tuning on Vespa 125-150-200. Both components have been developed and tested, together, on the dyno and track.

GRUPPO TERMICO
+
ALBERO MOTORE
**CYLINDER KIT
+
CRANKSHAFT**



26360010

TUNING KIT CORSA LUNGA 60mm
GRUPPO TERMICO IN ALLUMINIO
26032931 + 26081826
TUNING KIT LONG STROKE 60mm
ALUMINIUM CYLINDER KIT
26032931 + 26081826
"VESPONE RX" BOOSTER 190CC
"VESPONE RX" BOOSTER 190CC

26360011

TUNING KIT CORSA LUNGA 60mm
GRUPPO TERMICO IN ALLUMINIO
26032900 + 26081827
TUNING KIT LONG STROKE 60mm
ALUMINIUM CYLINDER KIT
26032900 + 26081827
PX 225 / "RACE 9TX" / 8P (CORSA 60)

26360013

TUNING KIT CORSA LUNGA 60mm
GRUPPO TERMICO IN ALLUMINIO
26032900 + 26081829
TUNING KIT LONG STROKE 60mm
ALUMINIUM CYLINDER KIT
26032900 + 26081829
PX 225 / "RACE 9TX" / 8P
(CORSA 60)



26360012

TUNING KIT CORSA LUNGA 60mm
GRUPPO TERMICO IN ALLUMINIO
26032901 + 26081827
TUNING KIT LONG STROKE 60mm
ALUMINIUM CYLINDER KIT
26032901 + 26081827
PX 225 / "884 RX" / 8P / DOPPIA
ALIMENTAZIONE (CORSA 60)

26360014

TUNING KIT CORSA LUNGA 60mm
GRUPPO TERMICO IN ALLUMINIO
26032901 + 26081829
TUNING KIT LONG STROKE 60mm
ALUMINIUM CYLINDER KIT
26032901 + 26081829
PX 225 / "884 RX" / 8P / DOPPIA
ALIMENTAZIONE (CORSA 60)



26270922

KIT PRIMARIA VESPA SMALL
Z 24/72 RACING
PRIMARY DRIVE VESPA SMALL
Z 24/72 RACING



Vista posteriore
Rear view

26270923

KIT PRIMARIA VESPA SMALL
Z 27/69 RACING
PRIMARY DRIVE VESPA SMALL
Z 27/69 RACING



Vista frontale
Front view



26270926

KIT PARASTRAPPI PRIMARIA
RACING VESPA SMALL
PRIMARY DRIVE SPARE
DAMPER VESPA SMALL

26271500

KIT REVISIONE PARASTRAPPI
REPAIRING KIT SPARE DAMPER
VESPA SMALL



Carter motore Pinasco SLAVE 125-150cc Pinasco SLAVE Crankcase 125-150cc

Realizzato in pressofusione, il nuovo carter motore Pinasco per Vespa Large è la punta di diamante della produzione, notevoli sono le migliorie apportate al modello originale, tra le quali:

- Cuscinetto lato volano maggiorato
- Riporti di materiale in corrispondenza dei travasi
- Aspirazione lamellare diretta sul carter con cuspidi inclinate
- Rinforzi nei punti critici

Nel modello 125-150cc il carter è stato lavorato per ospitare l'albero sia il classico albero con biella da 105mm sia il modello 200 con biella da 110mm

The new die-casted crankcase for Pinasco Vespa Large is the spearhead of our production, there are many improvements comparing to the original model, including:

- *Big bearing on flywheel side*
- *Extra material to work on ports*
- *Big Valve Intake*
- *Critical points have been reinforced*

On the model 125-150cc, the crankcase has been worked to accommodate the crankshaft of the model 200, increasing the size of the valve and using a connecting rod 110mm.

**NUOVO
NEW**

26482022

CARTER MOTORE COMPLETO
"SLAVE" LAMELLARE
PINASCO SLAVE CRANKCASE
VESPA PX 125-150



CODICE	APPLICAZIONE	SILENTBLOCK BRACCIO MOTORE	KIT PRIGIONIERI	SERIE CUSCINETTI DI BANCO	SILENTBLOCK AMM. POST.
ITEM	APPLICATION	ENGINE ARM SILENTBLOCK	SCREWS & BOLT SET	CRANCKSHAFT BEARING SET	REAR SHOCK SILENTBLOCK
26482022	VESPA LARGE 125/150	25482400	25482500	25412903	25482401
26482023	VESPA LARGE 200	25482400	25482501	25412903	25482401

Carter motore Pinasco SLAVE 200cc Pinasco SLAVE Crankcase 200cc

NUOVO
NEW

26482023

CARTER MOTORE COMPLETO
"SLAVE" LAMELLARE
PINASCO SLAVE CRANKCASE
VESPA PX 200



VESPA RACING

CODICE ITEM	PRODOTTO PRODUCT
25381100	COLLETTORE LAMELLARE COMPLETO COMPLETE INTAKE MANIFOLD
25381200	SUPPORTO PACCO LAMELLARE VALVE PACK HOLDER
25381300	PACCO LAMELLARE VALVE PACK
25381400	GUIDAFLUSSI FLOW GUIDE
25387300	KIT LAMELLE REED KIT
25536800	COLLETTORE ASPIRAZIONE COMPLETO COMPLETE INTAKE MANIFOLD
25536850	MANICOTTO IN GOMMA COMPLETO COMPLETE RUBBER SLEEVE

COMPONENTI INCLUSI NELLA CONFEZIONE

- Carter motore (1)
- Pacco lamellare completo (2)
- Collettore aspirazione completo (3)
- Serie prigionieri (4)
- Coppia silentblock motore (5)
- Silentblock ammortizzatore posteriore (6)

COMPONENTS INCLUDED IN THE PACKAGE

- Crankcase (1)
- Complete Valve Pack (2)
- Complete Intake Manifold (3)
- Screws Set (4)
- Pair of Engine Silentblock (5)
- Rear Shock Silentblock (6)



Gruppi Termici in Ghisa TForce Cast Iron Cylinder Kits TForce

Cilindro in ghisa perlitica additivata con distribuzione a 5 luci di travaso. Travasera concepita per garantire un'erogazione estremamente vigorosa sin dai bassi regimi. Testa di tipo troncoconico con banda di squish calcolata. Pistone in lega di alluminio ad alto tenore di silicio con due segmenti. Luce di scarico di forma ellittica ad ampia superficie e profilo tale da aumentare la durata dei segmenti. Diagramma studiato per garantire il giusto equilibrio tra coppia ai bassi regimi e potenza massima.

Cast iron cylinder pearlitic additivity with distribution 5 lights racking. The openings designed to ensure supply extremely vigorous since the low revs. Head with a truncated cone squish band calculated. Alloy piston high standard with two rings. Light exhaust elliptical in shape to large surface and profile that increase the duration of the segments. Diagram designed to ensure the right balance between the pair low revs and maximum power.



MARCA	MODELLO	CC	TEMPI	TFORCE	TFORCE MONOFASCIA
BRAND	MODEL	CC	STROKE	TFORCE	TFORCE SINGLE RING
VESPA	Vespa ET2 *50 - Carburatore	50	2	10040408	10041408
VESPA	Vespa ET2 *50- 2000	50	2	10040408	10041408
VESPA	Vespa LX *50 2T	50	2	10040408	10041408
VESPA	Vespa S (dal 2007)	50	2	10040408	10041408
VESPA	Vespa S *50 2T	50	2	10040408	10041408

Gruppi Termici in Alluminio GFORCE Aluminium Cylinder Kits GForce

Realizzati in alluminio con riporto galvanico, sono caratterizzati da un diagramma di distribuzione ed una conformazione delle luci tali da garantire un compromesso ideale tra coppia e potenza massima erogate. Le teste sono state sviluppate per l'uso di benzina senza piombo. I pistoni sono ad 1 segmento per garantire il massimo delle prestazioni.

Made from aluminium with galvanized coating, the thermal units have a distribution diagram and conformation of the openings that provide the ideal compromise between the torque and maximum power supplied. The heads have been developed for use with unleaded petrol. The pistons are made in one segment to allow maximum performances.



MARCA	MODELLO	CC	TEMPI	GFORCE	GFORCE MONOFASCIA
BRAND	MODEL	CC	STROKE	GFORCE	GFORCE SINGLE RING
VESPA	Vespa ET2 *50 - Carburatore	50	2	10059908	10051908
VESPA	Vespa ET2 *50- 2000	50	2	10059908	10051908
VESPA	Vespa LX *50 2T	50	2	10059908	10051908
VESPA	Vespa S (dal 2007)	50	2	10059908	10051908
VESPA	Vespa S *50 2T	50	2	10059908	10051908

Alberi motore Crankshafts

Alberi motore realizzati in acciaio K2D trattato termicamente, lavorati con macchinari a controllo numerico, assemblati e centrati con la massima cura utilizzando cuscinetti di biella di altissima qualità e bielle specifiche per competizione.

Crankshafts made of K2D steel heat-treated, CNC machined, assembled and centered, top quality rods and rod bearings.



MARCA	MODELLO	CC	TEMPI	CODICE
BRAND	MODEL	CC	STROKE	ITEM
VESPA	Vespa ET2 *50 - Carburatore	50	2	10080802
VESPA	Vespa ET2 *50- 2000	50	2	10080802
VESPA	Vespa LX *50 2T	50	2	10080802
VESPA	Vespa S (dal 2007)	50	2	10080802
VESPA	Vespa S *50 2T	50	2	10080802

Carburatori Ø 17,5 Carburettors Ø 17,5

Uno tra i carburatori scooter più evoluti in commercio, grazie al diffusore centrato ed alla conformazione a scudetto della valvola gas. Fornito con starter manuale o automatico, con tutti gli accessori per il montaggio e già tarato per ogni scooter.

One of the most advanced scooter carburettors available, thanks to the centred choke and shield conformation of the gas valve. Supplied with a manual or automatic starter, with all mounting accessories and pre-calibrated for each scooter.

MARCA	MODELLO	CC	TEMPI	CODICE
BRAND	MODEL	CC	STROKE	ITEM
VESPA	Vespa ET2 *50 - Carburatore	50	2	10294895
VESPA	Vespa ET2 *50- 2000	50	2	10294895
VESPA	Vespa LX *50 2T	50	2	10294895
VESPA	Vespa S (dal 2007)	50	2	10294895
VESPA	Vespa S *50 2T	50	2	10294895



Impianti di Alimentazione Ø 19-21-22-25 Carburettor Kits Ø 19-21-22-25

Carburatori con diametro da 19 a 25 mm, adatti a tutti gli scooter elaborati. Vengono forniti con tutti gli accessori per il montaggio e già tarati per ogni singolo scooter.

Carburettor from 19 to 25 mm, choke, suitable for all modified scooters. Supplied with all mounting accessories and pre-calibrated for each scooter.



MARCA	MODELLO	CC	TEMPI	IMPIANTI ALIMENTAZ. 19	IMPIANTI ALIMENTAZ. 21	IMPIANTI ALIMENTAZ. 22	IMPIANTI ALIMENTAZ. 25
BRAND	MODEL	CC	STROKE	FUEL FEEDS 19	FUEL FEEDS 21	FUEL FEEDS 22	FUEL FEEDS 25
VESPA	Vespa ET2 *50 - Carburatore	50	2	10294952	10294926	10294959	10294940
VESPA	Vespa ET2 *50- 2000	50	2	10294952	10294926	10294959	-
VESPA	Vespa LX *50 2T	50	2	10294952	10294926	10294959	10294940
VESPA	Vespa S (dal 2007)	50	2	10294952	10294926	10294959	10294940
VESPA	Vespa S *50 2T	50	2	10294952	10294926	10294959	10294940

Kit Lamelle per Pacco Lamellare Originale Reed Kits to fit the Original Valve Pack

Realizzate in fibra di carbonio, vengono fornite in diversi spessori a seconda del tipo di elaborazione effettuata e tipo di carburatore impiegato.

Made from carbon fiber in various thicknesses depending on the type of modification and carburettor used.

MARCA	MODELLO	CC	TEMPI	CODICE
BRAND	MODEL	CC	STROKE	ITEM
VESPA	Vespa ET2 *50 - Carburatore	50	2	10387503
VESPA	Vespa ET2 *50- 2000	50	2	10387503
VESPA	Vespa LX *50 2T	50	2	10387503
VESPA	Vespa S (dal 2007)	50	2	10387503
VESPA	Vespa S *50 2T	50	2	10387503

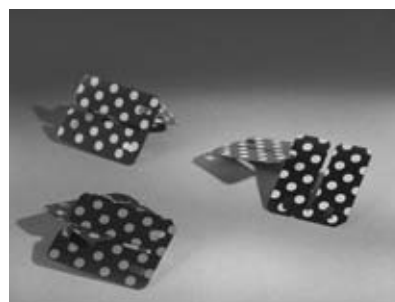

Variatori OVERDRIVE Speed Variator OVERDRIVE

Frutto della raffinata tecnologia Pinasco, questi variatori permettono di incrementare l'escursione complessiva rispetto ai componenti di serie, migliorando notevolmente la funzionalità e le prestazioni degli scooter. Disponibili per tutti gli scooter da 50 a 500 cc.

The fruit of Pinasco technology, these variators extend the overall operating range compared to OEM components, resulting in substantial improvement to the functionality and performance of the scooters. They are available for scooters from 50 to 500 cc.



MARCA	MODELLO	CC	TEMPI	OVERDRIVE	OVERDRIVE RULLI Ø19
BRAND	MODEL	CC	STROKE	OVERDRIVE	OVERDRIVE ROLLERS Ø19
VESPA	Vespa 946 - 125 ABS i.e.	125	4	10260436	-
VESPA	Vespa ET2 *50 - Carburatore	50	2	10260255	-
VESPA	Vespa ET2 *50- 2000	50	2	10260275	10260254
VESPA	Vespa ET4 *50 4T	50	4	10260256	10260256
VESPA	Vespa ET4 125	125	4	10260301	-
VESPA	Vespa ET4 125 (Leader Engine)	125	4	10260319	-
VESPA	Vespa ET4 150 (Leader Engine)	150	4	10260319	-
VESPA	Vespa Granturismo 125 GT	125	4	10260319	-
VESPA	Vespa GT 200	200	4	10260329	-
VESPA	Vespa GTS 125 i.e. Super	125	4	10260319	-
VESPA	Vespa GTS 250 i.e.	250	4	10260329	-
VESPA	Vespa GTS 300 i.e. Super	300	4	10260329	-
VESPA	Vespa GTV 125	125	4	10260319	-
VESPA	Vespa GTV 250 i.e.	250	4	10260329	-
VESPA	Vespa GTV 300 i.e. euro 3	300	4	10260329	-
VESPA	Vespa L 125	125	4	10260319	-
VESPA	Vespa L 200	200	4	10260329	-
VESPA	Vespa LX *50 2T	50	2	10260254	10260254
VESPA	Vespa LX *50 4T	50	4	10260256	10260256
VESPA	Vespa LX 125 3V i.e. euro 3 > 2012	125	4	10260436	-
VESPA	Vespa LX 125 4T	125	4	10260319	-
VESPA	Vespa LX 125 4T i.e. euro 3	125	4	10260319	-
VESPA	Vespa LX 150 3V i.e. euro 3 > 2013	150	4	10260436	-
VESPA	Vespa LX 150 4T	150	4	10260319	-
VESPA	Vespa LX 150 4T i.e. euro 3	150	4	10260319	-
VESPA	Vespa LXV 125 i.e. euro 3	125	4	10260319	-
VESPA	Vespa Primavera 125 3V i.e. euro 3 > 2014	125	4	10260436	-
VESPA	Vespa S (dal 2007)	50	2	10260254	10260254
VESPA	Vespa S *50 2T	50	2	10260254	10260254
VESPA	Vespa S *50 4T- 4V	50	4	10260256	-
VESPA	Vespa S 125 3V i.e. 4T euro 3 > 2012	125	4	10261436	-
VESPA	Vespa S 125 4T euro 3	125	4	10260319	-
VESPA	Vespa S 150 4T euro 3	150	4	10260319	-

B>LOCK
ASSEMBLY SYSTEM

B-LOCK è l'esclusivo sistema di montaggio della bronzina di scorrimento mozzo variatore, principalmente sui variatori per maxi scooter, effettuato senza nessun tipo di deformazione della stessa. Con l'impiego di questa tecnologia, oltre ad avere un perfetto accoppiamento senza rischi di rottura o fuoriuscita, la bronzina mantiene le sue dimensioni iniziali, garantendo costanza di prestazioni a caldo e nell'uso intensivo, assicurando una durata nel tempo superiore anche a quella dei variatori originali.

B-LOCK is the unique assembly system of variator bush, mainly on variators for maxi scooter, performed without any deformation. Using this technology, besides having a perfect coupling without risk of breakage or leakage, the bush keeps its own dimension, ensuring constant performance in hot and intensive use, as well as a superior durability even to the original variators.

Variatori OVERSLIDE Speed Variator OVERSLIDE

Frutto della raffinata tecnologia Pinasco, questi variatori permettono di incrementare l'escursione complessiva rispetto ai componenti di serie, migliorando notevolmente la funzionalità e le prestazioni degli scooter. Il kit è abbinato al cuscinetto assiale spring slider che elimina la dannosa torsione della molla durante l'escursione del variatore migliorando le prestazioni e la fluidità di marcia.

The fruit of Pinasco technology these variator extend the overall operating range compared to OEM components, resulting in substantial improvement to the functionality and performance of the scooter. The kit is combined with axial bearing Spring Slider that eliminates harmful torsion spring during the excursion variator improving performance and fluidity of running.



B>LOCK
ASSEMBLY SYSTEM

MARCA	MODELLO	CC	TEMPI	OVERSLIDE	OVERSLIDE RULLI Ø19
BRAND	MODEL	CC	STROKE	OVERSLIDE	OVERSLIDE ROLLERS Ø19
VESPA	Vespa 946 - 125 ABS i.e.	125	4	10261436	-
VESPA	Vespa ET2 *50 - Carburatore	50	2	10261255	-
VESPA	Vespa ET2 *50- 2000	50	2	10261275	10261254
VESPA	Vespa ET4 *50 4T	50	4	10261256	10261256
VESPA	Vespa ET4 125	125	4	10261301	-
VESPA	Vespa ET4 125 (Leader Engine)	125	4	10261319	-
VESPA	Vespa ET4 150 (Leader Engine)	150	4	10261319	-
VESPA	Vespa Granturismo 125 GT	125	4	10261319	-
VESPA	Vespa GT 200	200	4	10261329	-
VESPA	Vespa GTS 125 i.e. Super	125	4	10261319	-
VESPA	Vespa GTS 250 i.e.	250	4	10261329	-
VESPA	Vespa GTS 300 i.e. Super	300	4	10261329	-
VESPA	Vespa GTV 125	125	4	10261319	-
VESPA	Vespa GTV 250 i.e.	250	4	10261329	-
VESPA	Vespa GTV 300 i.e. euro 3	300	4	10261329	-
VESPA	Vespa L 125	125	4	10261319	-
VESPA	Vespa L 200	200	4	10261329	-
VESPA	Vespa LX *50 2T	50	2	10261254	10261254
VESPA	Vespa LX *50 4T	50	4	10261256	10261256
VESPA	Vespa LX 125 3V i.e. euro 3 > 2012	125	4	10261436	-
VESPA	Vespa LX 125 4T	125	4	10261319	-
VESPA	Vespa LX 125 4T i.e. euro 3	125	4	10261319	-
VESPA	Vespa LX 150 3V i.e. euro 3 > 2013	150	4	10261436	-
VESPA	Vespa LX 150 4T	150	4	10261319	-
VESPA	Vespa LX 150 4T i.e. euro 3	150	4	10261319	-
VESPA	Vespa LXV 125 i.e. euro 3	125	4	10261319	-
VESPA	Vespa Primavera 125 3V i.e. euro 3 > 2014	125	4	10261436	-
VESPA	Vespa S (dal 2007)	50	2	10261254	10261254
VESPA	Vespa S *50 2T	50	2	10261254	10261254
VESPA	Vespa S *50 4T- 4V	50	4	10261256	-
VESPA	Vespa S 125 3V i.e. 4T euro 3 > 2012	125	4	10261436	-
VESPA	Vespa S 125 4T euro 3	125	4	10261319	-
VESPA	Vespa S 150 4T euro 3	150	4	10261319	-

Frizione Pinasco Pinasco Clutch

Frizione completa alleggerita in fusione di alluminio, aumenta notevolmente la ripresa garantendo riprese più scattanti, il kit viene fornito con molle di diversa durezza per una regolazione ideale

Complete lightened clutch made of aluminium. It increases the acceleration. Some springs with different strength are included in the kit.



MARCA	MODELLO	CC	TEMPI	CODICE
BRAND	MODEL	CC	STROKE	ITEM
VESPA	Vespa ET2 *50 - Carburatore	50	2	10090103 *
VESPA	Vespa ET2 *50- 2000	50	2	10090103 *
VESPA	Vespa LX *50 2T	50	2	10090103 *
VESPA	Vespa S (dal 2007)	50	2	10090103 *
VESPA	Vespa S *50 2T	50	2	10090103 *

Cinghie di Trasmissione Transmission Belts

Cinghie di trasmissione realizzate con mescola di gomma e inserti di kevlar nel tessuto radiale che assicurano un grip ottimale sulla puleggia e eccellenti doti di affidabilità in qualsiasi tipo di impiego.

Transmission belts made with a mix of rubber and Kevlar inserts in which provide an optimal grip on the pulley and excellent skills in reliability and any type of use.

MARCA	MODELLO	CC	TEMPI	CODICE
BRAND	MODEL	CC	STROKE	ITEM
VESPA	Vespa ET2 *50 - Carburatore	50	2	10301414
VESPA	Vespa ET4 125	125	4	10301430
VESPA	Vespa ET4 125 (Leader Engine)	125	4	10301433
VESPA	Vespa ET4 150 (Leader Engine)	150	4	10301433
VESPA	Vespa Granturismo 125 GT	125	4	10301433
VESPA	Vespa GT 200	200	4	10301436
VESPA	Vespa GTV 125	125	4	10301433
VESPA	Vespa L 125	125	4	10301433
VESPA	Vespa L 200	200	4	10301436
VESPA	Vespa LX *50 2T	50	2	10301440
VESPA	Vespa LX 125 4T	125	4	10301433
VESPA	Vespa LX 150 4T	150	4	10301433
VESPA	Vespa S (dal 2007)	50	2	10301440
VESPA	Vespa S *50 2T	50	2	10301440
VESPA	Vespa S 125 4T euro 3	125	4	10301433



Spring Slider

Esclusivo dispositivo, coperto da brevetto internazionale, costituito da un cuscinetto assiale ultrapiatto abbinato ad una specifica molla di contrasto: isolando la molla di contrasto dalla torsione delle pulegge condotte, allunga la vita della molla migliorando notevolmente prestazioni ed affidabilità.

This exclusive item has a international patent. It is made up of an ultraflat axial bearing combined with a particular return spring: isolation of the return spring from the torsion of the driven pulleys lengthens the working life of the spring, thus notably improving performance and reliability.



MARCA	MODELLO	CC	TEMPI	SPRING SLIDER	MOLLE RINFORZATE	MOLLE RACING
BRAND	MODEL	CC	STROKE	SPRING SLIDER	REINFORCED SPRINGS	RACING SPRINGS
VESPA	Vespa 946 - 125 ABS i.e.	125	4	10412098	10320025	-
VESPA	Vespa ET2 *50 - Carburatore	50	2	10412077	10322006	10322011
VESPA	Vespa ET2 *50- 2000	50	2	10412077	10322006	10322011
VESPA	Vespa ET4 *50 4T	50	4	10412077	10322006	10322011
VESPA	Vespa ET4 125	125	4	10412081	-	-
VESPA	Vespa ET4 125 (Leader Engine)	125	4	10412085	10322029	-
VESPA	Vespa ET4 150 (Leader Engine)	150	4	10412085	10322029	-
VESPA	Vespa Granturismo 125 GT	125	4	10412085	10322029	-
VESPA	Vespa GT 200	200	4	10412085	10322029	-
VESPA	Vespa GTS 125 i.e. Super	125	4	10412085	10322029	-
VESPA	Vespa GTS 250 i.e.	250	4	10412085	10322029	-
VESPA	Vespa GTS 300 i.e. Super	300	4	10412085	10322029	-
VESPA	Vespa GTV 125	125	4	10412085	10322029	-
VESPA	Vespa GTV 250 i.e.	250	4	10412085	10322029	-
VESPA	Vespa GTV 300 i.e. euro 3	300	4	10412085	10322029	-
VESPA	Vespa L 125	125	4	10412085	10322029	-
VESPA	Vespa L 200	200	4	10412085	10322029	-
VESPA	Vespa LX *50 2T	50	2	10412077	10322006	10322011
VESPA	Vespa LX *50 4T	50	4	10412077	10322006	10322011
VESPA	Vespa LX 125 3V i.e. euro 3 > 2012	125	4	10412098	10320025	-
VESPA	Vespa LX 125 4T	125	4	10412085	10322029	-
VESPA	Vespa LX 125 4T i.e. euro 3	125	4	10412085	10322029	-
VESPA	Vespa LX 150 3V i.e. euro 3 > 2013	150	4	10412098	10320025	-
VESPA	Vespa LX 150 4T	150	4	10412085	10322029	-
VESPA	Vespa LX 150 4T i.e. euro 3	150	4	10412085	10322029	-
VESPA	Vespa LXV 125 i.e. euro 3	125	4	10412085	10322029	-
VESPA	Vespa Primavera 125 3V i.e. euro 3 > 2014	125	4	10412098	10320025	-
VESPA	Vespa S (dal 2007)	50	2	10412077	10322006	10322011
VESPA	Vespa S *50 2T	50	2	10412077	10322006	10322011
VESPA	Vespa S *50 4T- 4V	50	4	10412077	10322006	10322011
VESPA	Vespa S 125 3V i.e. 4T euro 3 > 2012	125	4	10412098	10320025	-
VESPA	Vespa S 125 4T euro 3	125	4	10412085	10322029	-
VESPA	Vespa S 150 4T euro 3	150	4	10412085	10322029	-

Molle di Contrasto Variatore Variator Return Springs

Molle di contrasto specifiche per scooter elaborati, indispensabili per una messa a punto ottimale della trasmissione automatica. Realizzate con acciai silicati, avvolgimento sinistrorso e disponibili con diversi carichi, a seconda delle esigenze.

Specific return springs for scooters are indispensable for optimal performance of the automatic transmission. These are made from silicate steels with counter-clockwise winding and are available with different loads to meet all requirements.



MARCA	MODELLO	CC	TEMPI	BIANCO +20%	GIALLO +40%	ROSSO +60%	NERO +80%	BLU +100%
BRAND	MODEL	CC	STROKE	WHITE +20%	YELLOW +40%	RED +60%	BLACK +80%	BLUE +100%
VESPA	Vespa 946 - 125 ABS i.e.	125	4	-	10320025	-	-	-
VESPA	Vespa ET2 *50 - Carburatore	50	2	10320016	10320006	10320011	10320013	10320014
VESPA	Vespa ET2 *50- 2000	50	2	10320016	10320006	10320011	10320013	10320014
VESPA	Vespa ET4 *50 4T	50	4	10320016	10320006	10320011	10320013	10320014
VESPA	Vespa ET4 125	125	4	-	-	-	-	-
VESPA	Vespa ET4 125 (Leader Engine)	125	4	10320029	-	-	-	-
VESPA	Vespa ET4 150 (Leader Engine)	150	4	10320029	-	-	-	-
VESPA	Vespa Granturismo 125 GT	125	4	10320029	-	-	-	-
VESPA	Vespa GT 200	200	4	10320029	-	-	-	-
VESPA	Vespa GTS 125 i.e. Super	125	4	10320029	-	-	-	-
VESPA	Vespa GTS 250 i.e.	250	4	10320029	-	-	-	-
VESPA	Vespa GTS 300 i.e. Super	300	4	10320029	-	-	-	-
VESPA	Vespa GTV 125	125	4	10320029	-	-	-	-
VESPA	Vespa GTV 250 i.e.	250	4	10320029	-	-	-	-
VESPA	Vespa GTV 300 i.e. euro 3	300	4	10320029	-	-	-	-
VESPA	Vespa L 125	125	4	10320029	-	-	-	-
VESPA	Vespa L 200	200	4	10320029	-	-	-	-
VESPA	Vespa LX *50 2T	50	2	10320016	10320006	10320011	10320013	10320014
VESPA	Vespa LX *50 4T	50	4	10320016	10320006	10320011	10320013	10320014
VESPA	Vespa LX 125 3V i.e. euro 3 > 2012	125	4	-	10320025	-	-	-
VESPA	Vespa LX 125 4T	125	4	10320029	-	-	-	-
VESPA	Vespa LX 125 4T i.e. euro 3	125	4	10320029	-	-	-	-
VESPA	Vespa LX 150 3V i.e. euro 3 > 2013	150	4	-	10320025	-	-	-
VESPA	Vespa LX 150 4T	150	4	10320029	-	-	-	-
VESPA	Vespa LX 150 4T i.e. euro 3	150	4	10320029	-	-	-	-
VESPA	Vespa LXV 125 i.e. euro 3	125	4	10320029	-	-	-	-
VESPA	Vespa Primavera 125 3V i.e. euro 3 > 2014	125	4	-	10320025	-	-	-
VESPA	Vespa S (dal 2007)	50	2	10320016	10320006	10320011	10320013	10320014
VESPA	Vespa S *50 2T	50	2	10320016	10320006	10320011	10320013	10320014
VESPA	Vespa S *50 4T- 4V	50	4	10320016	10320006	10320011	10320013	10320014
VESPA	Vespa S 125 3V i.e. 4T euro 3 > 2012	125	4	-	10320025	-	-	-
VESPA	Vespa S 125 4T euro 3	125	4	10320029	-	-	-	-
VESPA	Vespa S 150 4T euro 3	150	4	10320029	-	-	-	-



Kit Molle Frizione Rinforzate Powered Clutch Springs Kit

Molle frizione per scooter e maxi scooter realizzate in acciaio al silicio con diversi carichi in base al regime d'innesto. Tarature facilmente riconoscibili dalle varie colorazioni.

Clutch springs for scooters and maxi scooters made from silicon steel with differing loads depending on the coupling speed. The calibrations are colour-coded.



MARCA	MODELLO	CC	TEMPI	CODICE
BRAND	MODEL	CC	STROKE	ITEM
VESPA	Vespa 946 - 125 ABS i.e.	125	4	10371057
VESPA	Vespa ET2 *50 - Carburatore	50	2	10371052
VESPA	Vespa ET2 *50- 2000	50	2	10371052
VESPA	Vespa ET4 *50 4T	50	4	-
VESPA	Vespa ET4 125	125	4	-
VESPA	Vespa ET4 125 (Leader Engine)	125	4	10371057
VESPA	Vespa ET4 150 (Leader Engine)	150	4	10371057
VESPA	Vespa Granturismo 125 GT	125	4	10371057
VESPA	Vespa GT 200	200	4	10371057
VESPA	Vespa GTS 125 i.e. Super	125	4	-
VESPA	Vespa GTS 250 i.e.	250	4	10371057
VESPA	Vespa GTS 300 i.e. Super	300	4	10371057
VESPA	Vespa GTV 125	125	4	10371057
VESPA	Vespa GTV 250 i.e.	250	4	10371057
VESPA	Vespa GTV 300 i.e. euro 3	300	4	-
VESPA	Vespa L 125	125	4	10371057
VESPA	Vespa L 200	200	4	10371057
VESPA	Vespa LX *50 2T	50	2	10371052
VESPA	Vespa LX *50 4T	50	4	-
VESPA	Vespa LX *50 4V euro 2	50	4	-
VESPA	Vespa LX 125 3V i.e. euro 3 > 2012	125	4	10371057
VESPA	Vespa LX 125 4T	125	4	10371057
VESPA	Vespa LX 125 4T i.e. euro 3	125	4	10371057
VESPA	Vespa LX 150 3V i.e. euro 3 > 2013	150	4	10371057
VESPA	Vespa LX 150 4T	150	4	10371057
VESPA	Vespa LX 150 4T i.e. euro 3	150	4	10371057
VESPA	Vespa LXV 125 i.e. euro 3	125	4	10371057
VESPA	Vespa Primavera 125 3V i.e. euro 3 > 2014	125	4	10371057
VESPA	Vespa S (dal 2007)	50	2	10371052
VESPA	Vespa S *50 2T	50	2	10371052
VESPA	Vespa S *50 4T- 4V	50	4	-
VESPA	Vespa S 125 3V i.e. 4T euro 3 > 2012	125	4	10371057
VESPA	Vespa S 125 4T euro 3	125	4	10371057
VESPA	Vespa S 150 4T euro 3	150	4	10371057

OPTIPULL Semipuleggia Condotta Mobile Mobile Pulley System OPTIPULL

Speciale puleggia condotta con camme di apertura riviste per ottimizzare il funzionamento della trasmissione ed eliminare tutti i dannosi cali di giri e di potenza trasmessa alla ruota: ogni correttore di coppia è dotato di cave con due diverse angolazioni.

Special driven pulley with opening cams to optimize the operation of the transmission and to eliminate all harmful falloffs in engine speed and power transmitted to the wheel: each torque adjuster is fitted with guides with two different runnels.



MARCA	MODELLO	CC	TEMPI	CODICE
BRAND	MODEL	CC	STROKE	ITEM
VESPA	Vespa ET2 *50 - Carburatore	50	2	10404093
VESPA	Vespa ET2 *50- 2000	50	2	10404095
VESPA	Vespa ET4 *50 4T	50	4	10404095
VESPA	Vespa LX *50 2T	50	2	10404095
VESPA	Vespa LX *50 4T	50	4	10404095
VESPA	Vespa S (dal 2007)	50	2	10404095
VESPA	Vespa S *50 2T	50	2	10404095



Ingranaggi di Trasmissione | *Transmission Gears*

Ingranaggi di trasmissione a denti dritti rasati con rapporto calcolato per motori elaborati. Realizzati in acciaio cementato, rettificato e temprato, sono estremamente resistenti e silenziosi.

Transmission gears with trimmed straight teeth and ratio for modified engines. Made from casehardened, ground and hardened steel, they are extremely resistant and silent in operation.

MARCA	MODELLO	CC	TEMPI	CODICE	Z
BRAND	MODEL	CC	STROKE	ITEM	Z
VESPA	Vespa ET2 *50 - Carburatore	50	2	10274681 cal. 17,67	15-38
VESPA	Vespa ET2 *50- 2000	50	2	10274652	14-39
VESPA	Vespa ET4 125	125	4	10274614	14-47
VESPA	Vespa ET4 125 (Leader Engine)	125	4	10274654	16-42
VESPA	Vespa L 125	125	4	10274654	16-42
VESPA	Vespa L 200	200	4	10274654	16-42
VESPA	Vespa LX *50 2T	50	2	10274653	16-37
VESPA	Vespa S (dal 2007)	50	2	10274653	16-37
VESPA	Vespa S *50 2T	50	2	10274653	16-37



Ammortizzatori | *Shock Absorbers*

Gli ammortizzatori oleopneumatici PINASCO a doppio effetto rappresentano l'evoluzione tecnologica nel campo delle sospensioni regolabili rispettando le normative CE. Gli ammortizzatori PINASCO sono realizzati con materiale di altissima qualità MADE IN ITALY, ghiera di regolazione in alluminio ricavate dal pieno, supporto molla in acciaio lavorato a CNC e cromato, molla a doppio effetto calibrata in acciaio armonico. La forza di reazione di un ammortizzatore è data dalla resistenza che l'olio in esso contenuto incontra nel passaggio attraverso le valvole, costituite da fori calibrati e da otturatori a dischi precariati. La sospensione, tramite una ghiera di registro millimetrica, è in grado di precaricare la molla e di creare una taratura di compressione che varia in base alle esigenze del pilota. Gli ammortizzatori PINASCO sono il connubio perfetto tra sportività e piacere di guida e regalano al pilota emozioni uniche ad ogni curva garantendo il massimo della sicurezza sia in tenuta di strada che nelle frenate più brusche.

Pinasco double-action shock absorbers represent technological developments in the field of adjustable suspension according to Europe standards. The Pinasco shock absorbers are MADE IN ITALY with the highest quality material, the adjusting rings are machined from solid, steel spring support are machined CNC and chrome-plated, double action springs are made of calibrated steel. The reaction force of a shock absorber is given by the resistance that the oil contained in it encounters when passing through the valves, consisting of calibrated holes and discs. With an adjusting millimetric ring the suspension is able to preload the spring and to create a calibration compression which changes according to the needs of the driver. The shock absorbers are the perfect combination of sportiness and driving pleasure, they give unbelievable driving emotions and maximum safety.

CODICE	APPLICAZIONE	CC	TEMPI	ANTERIORI	POSTERIORI
ITEM	MODEL	CC	STROKE	FRONT	REAR
VESPA	Vespa 946 - 125 ABS i.e.	125	4	25441005	-
VESPA	Vespa ET2 *50 - Carburatore	50	2	-	-
VESPA	Vespa ET2 *50- 2000	50	2	-	-
VESPA	Vespa ET4 *50 4T	50	4	-	-
VESPA	Vespa ET4 125	125	4	-	-
VESPA	Vespa ET4 125 (Leader Engine)	125	4	-	-
VESPA	Vespa ET4 150 (Leader Engine)	150	4	-	-
VESPA	Vespa Granturismo 125 GT	125	4	25441005	25441006
VESPA	Vespa GT 200	200	4	25441005	25441006
VESPA	Vespa GTS 125 i.e. Super	125	4	25441005	25441006
VESPA	Vespa GTS 250 i.e.	250	4	25441005	25441006
VESPA	Vespa GTS 300 i.e. Super	300	4	25441005	25441006
VESPA	Vespa GTV 125	125	4	25441005	25441006
VESPA	Vespa GTV 250 i.e.	250	4	25441005	25441006
VESPA	Vespa GTV 300 i.e. euro 3	300	4	25441005	25441006
VESPA	Vespa L 125	125	4	-	-
VESPA	Vespa L 200	200	4	-	-
VESPA	Vespa LX *50 2T	50	2	25441007	25441008
VESPA	Vespa LX *50 4T	50	4	25441007	25441008
VESPA	Vespa LX *50 4V euro 2	50	4	25441007	25441008
VESPA	Vespa LX 125 3V i.e. euro 3 > 2012	125	4	25441007	25441008
VESPA	Vespa LX 125 4T	125	4	25441007	25441008
VESPA	Vespa LX 125 4T i.e. euro 3	125	4	25441007	25441008
VESPA	Vespa LX 150 3V i.e. euro 3 > 2013	150	4	25441007	25441008
VESPA	Vespa LX 150 4T	150	4	25441007	25441008
VESPA	Vespa LX 150 4T i.e. euro 3	150	4	25441007	25441008
VESPA	Vespa LXV 125 i.e. euro 3	125	4	25441007	25441008
VESPA	Vespa Primavera 125 3V i.e. euro 3 > 2014	125	4	-	-
VESPA	Vespa S (dal 2007)	50	2	-	-
VESPA	Vespa S *50 2T	50	2	-	-
VESPA	Vespa S *50 4T- 4V	50	4	-	-
VESPA	Vespa S 125 3V i.e. 4T euro 3 > 2012	125	4	-	-
VESPA	Vespa S 125 4T euro 3	125	4	-	-
VESPA	Vespa S 150 4T euro 3	150	4	-	-



Gruppi Termici in Alluminio Aluminum Cylinder Kits

Gruppi termici Pinasco in alluminio, l'ideale per chi vuole dare un po' di brio al proprio cinquantino. I kit non necessitano di particolari conoscenze tecniche per essere montati e si adattano facilmente a tutti i ciclomotori CIAO, SI, BRAVO. L'alluminio con riporto di Nicasil conferisce ai gruppi termici Pinasco una robustezza eccezionale e una resistenza unica garantendo prestazioni superiori in tutti i regimi di utilizzo.

Pinasco aluminum cylinder kit to give some verve to your moped 50cc. The installation of these kits does not require technical experience and the kit easily adapts to all CIAO SI and BRAVO. The aluminum with Nicasil gives to Pinasco engines strength and resistance really incredible and higher performances at any regime of utilization.

**+ SPEED
- TORQUE**



25027891

KIT PIAGGIO CIAO 60CC SP.010
CILINDRO IN ALLUMINIO - NERO
ALUMINUM CYLINDER KIT PIAGGIO CIAO
60CC PIN Ø10 - BLACK

25027892

KIT PIAGGIO CIAO 60CC SP.12
CILINDRO IN ALLUMINIO - NERO
ALUMINUM CYLINDER KIT PIAGGIO CIAO
60CC PIN Ø12 - BLACK

25028891

KIT PIAGGIO SI 60CC SP.10
CILINDRO IN ALLUMINIO - NERO
ALUMINUM CYLINDER KIT PIAGGIO SI
60CC PIN Ø10 - BLACK

25028892

KIT PIAGGIO SI 60CC SP.12
CILINDRO IN ALLUMINIO - NERO
ALUMINUM CYLINDER KIT PIAGGIO SI
60CC PIN Ø12 - BLACK

**- SPEED
+ TORQUE**



25028493

KIT PIAGGIO CIAO 75CC SP.010
CILINDRO IN ALLUMINIO - GRIGIO
ALUMINUM CYLINDER KIT PIAGGIO CIAO
75CC PIN Ø10 - GREY

25028494

KIT PIAGGIO CIAO 75CC SP.12
CILINDRO IN ALLUMINIO - GRIGIO
ALUMINUM CYLINDER KIT PIAGGIO CIAO
75CC PIN Ø12 - GREY

25028903

KIT PIAGGIO SI 75CC SP.10 CILINDRO
IN ALLUMINIO - GRIGIO
ALUMINUM CYLINDER KIT PIAGGIO SI
75CC PIN Ø10 - GREY

25028904

KIT PIAGGIO SI 75CC SP.12 CILINDRO
IN ALLUMINIO - GRIGIO
ALUMINUM CYLINDER KIT PIAGGIO SI
75CC PIN Ø12 - GREY

**+ SPEED
- TORQUE**



25028491

KIT PIAGGIO CIAO 75CC SP.010
CILINDRO IN ALLUMINIO - NERO
ALUMINUM CYLINDER KIT PIAGGIO CIAO
75CC PIN Ø10 - BLACK

25028492

KIT PIAGGIO CIAO 75CC SP.12
CILINDRO IN ALLUMINIO - NERO
ALUMINUM CYLINDER KIT PIAGGIO CIAO
75CC PIN Ø12 - BLACK

25028901

KIT PIAGGIO SI 75CC SP.10
CILINDRO IN ALLUMINIO - NERO
ALUMINUM CYLINDER KIT PIAGGIO SI
75CC PIN Ø10 - BLACK

25028902

KIT PIAGGIO SI 75CC SP.12
CILINDRO IN ALLUMINIO - NERO
ALUMINUM CYLINDER KIT PIAGGIO SI
75CC PIN Ø12 - BLACK

Carter Lamellare Doppia Aspirazione **Double Reed Valve Intake Crankcase**

Carter per ciclomotore Piaggio ad aspirazione laterale lamellare realizzato con diametri da 42 o 46mm che permette il montaggio di 2 carburatori SHA 13/13. L'aspirazione avviene tramite un sistema a 2 lamelle posizionate al centro del cuscinetto a sfere di destra. Per il funzionamento ottimale del sistema è necessario forare l'albero motore originale o montare l'albero Pinasco "COMPETIZIONE" art. 26081854 Spinotto Ø 12mm. Il kit comprende tutti i componenti necessari al montaggio.

Crankcase for Piaggio moped with lateral reed valve intake, made in 42mm or 46mm, which allows the installation of two carburetors SHA 13/13. It works with 2 reeds positioned at the center of the right side bearing. To get the best you have to drill the original crankshaft or fit the crankshaft Pinasco "COMPETIZIONE" item 26081854 Piston Pin Ø 12mm. The kit includes all required components for assembly.

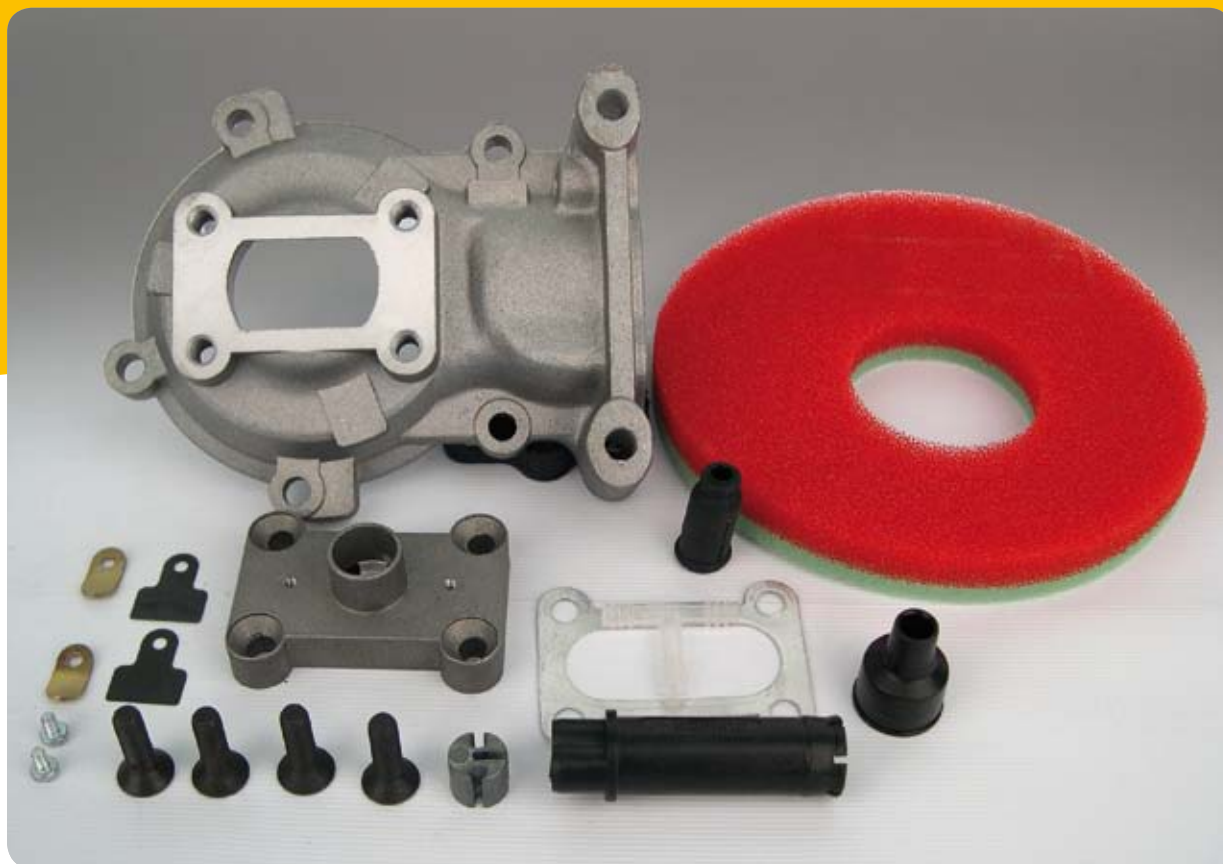

25020881

CARTER LAMELLARE
DOPPIA ASPIRAZIONE Ø42 CIAO - SI - BRAVO
CARTER DOUBLE VALVE
INTAKE Ø42 CIAO - SI - BRAVO

25020882

CARTER LAMELLARE
DOPPIA ASPIRAZIONE Ø46 CIAO - SI - BRAVO
CARTER DOUBLE VALVE
INTAKE Ø46 CIAO - SI - BRAVO

Carburatore 13/13 **Carburettor 13/13**

25294892 Carburatore Piaggio Ciao PX
CARBURETTOR PIAGGIO CIAO PX

25294893 Carburatore Piaggio SI
CARBURETTOR PIAGGIO SI



Alberi Motore Anticipati Advanced Crankshafts

Albero Anticipato ad alte prestazioni utilizzato alla "Monferraglia".
L'albero motore Pinasco, costruito in acciaio cementato, cromato, anticipato e lucidato nel lato ammissione, garantisce elevate prestazioni in ogni condizione di guida, anche le più gravose.

*High Performance Advanced Crankshaft often used in "Monferraglia".
The Pinasco crankshaft, built in hardened steel, chromed, advanced and polished on admission side, guarantees high performance in all driving conditions, even heaviest.*



25080854 ALBERO MOTORE ANTICIPATO Ciao - Si Spinotto 12
ADVANCED CRANKSHAFT Ciao - Si Piston Pin 12

25080855 ALBERO MOTORE ANTICIPATO Ciao - Si Spinotto 10
ADVANCED CRANKSHAFT Ciao - Si Piston Pin 10

Alberi Motore COMPETIZIONE Crankshafts COMPETIZIONE

Albero Anticipato Competizione ad altissime prestazioni per uso competizione.
L'albero costruito in acciaio cementato, cromato nel lato ammissione e lucidato per essere inattaccabile alla polvere è stato anticipato e sbilanciato con inserti in tungsteno per aumentare le prestazioni sin dai bassi regimi, la gabbia a rulli è argentata per aumentare la resistenza e la scorrevolezza. Spallamento circolare con foro per l'ammissione lamellare Pinasco; monta un cuscinetto 35x17x10mm. L'albero Competizione Pinasco garantisce prestazioni elevatissime in ogni condizione di guida, anche le più gravose.

*High Performance, Racing, Advanced Crankshaft.
The Pinasco "COMPETIZIONE" crankshaft, built in hardened steel, chromed, advanced and polished on admission side. It's unbalanced with tungsten inserts to increase the performance even at low speed, the silvered roller cage increases the strength and smoothness. Reed valve intake side with a hole for Pinasco crankcase double reed valve intake; you can fit a bearing 35x17x10mm. The Pinasco "COMPETIZIONE" crankshaft ensures high performance in any driving conditions, even heaviest.*



26081854 ALBERO MOTORE "COMPETIZIONE"
CIAO - SI SPINOTTO 12
CRANKSHAFT "COMPETIZIONE"
CIAO - SI PISTON PIN 12



Pinasco sponsor tecnico Monferraglia 2013-2014

Molle Frizione per ciclomotore Clutch Springs for Moped

Molle frizione per ciclomotore con puleggia fissa realizzate in acciaio al silicio con diversi carichi in base al regime di innesto. Tarature facilmente riconoscibili dalle varie colorazioni. Sono fondamentali per impostare il regime di innesto della frizione centrifuga e quindi caratterizzare lo spunto da fermo.

Clutch springs for moped, with fixed pulley, made of silicon steel with different loads. Easy setting recognizable by different colors. They are essentials to set the clutch engagement and the acceleration.



25091054

KIT MOLLE FRIZIONE RINFORZATE
REINFORCED SPRING KITS

Molle Forcella CIAO Fork Springs for CIAO

Molle rinforzate +20% per forcella originale Ciao
Reinforced springs +20% for original fork Ciao

25320100

COPPIA MOLLE FORCELLA RINFORZATE
PIAGGIO CIAO
PAIR FOR FORK REINFORCED SPRING
PIAGGIO CIAO

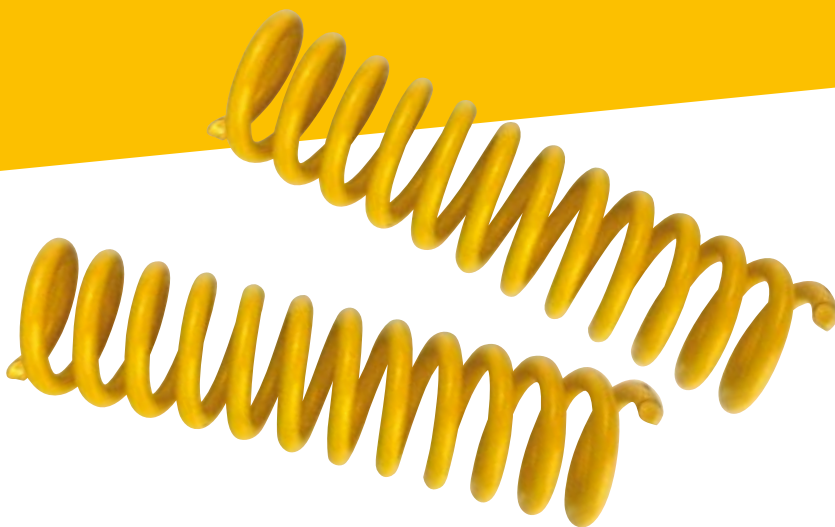

Molla di Contrasto Variatore Variator Return Spring

25320957

MOLLA DI CONTRASTO VIARIATORE CIAO
VARIATOR RETURN SPRING FOR CIAO

OVERDRIVE Pinasco per Ciclomotore Pinasco OVERDRIVE for Moped

Il variatore Pinasco Overdrive per ciclomotore è stato studiato per garantire prestazioni elevatissime, perfetta intercambiabilità ai componenti originali e affidabilità, caratteristiche che hanno reso il marchio Pinasco famoso nel mondo. La maggiore escursione complessiva consente l'inserimento di un rapporto più corto in accelerazione ed uno più lungo in velocità massima con ovvi vantaggi in termini di resa complessiva.

The Pinasco Overdrive variator for moped is designed to ensure high performance, reliability and perfect interchangeability with the original components, features which have made famous the Pinasco brand all over the world. The overall bigger drives allow a shorter ratio for acceleration and a longer one at maximum speed, with advantages in terms of overall performance.

25260217

VIARIATORE CIAO
VARIATOR FOR CIAO



Carburatori | Carburettors



06001800 CARBURATORE SHA 12 12 SI
CARBURETTOR SHA 12 12 SI

06001821 CARBURATORE SHA 12 10 CIAO
CARBURETTOR SHA 12 10 CIAO

06001851 CARBURATORE SHA 13 13 SI
CARBURETTOR SHA 13 13 SI

06002035 CARBURATORE SHA 12 12 CIAO
CARBURETTOR SHA 12 12 CIAO

06002044 CARBURATORE SHA 13 13 CIAO
CARBURETTOR SHA 13 13 CIAO

06002046 CARBURATORE SHA 13 13 CIAO
CARBURETTOR SHA 13 13 CIAO



06000583 CARBURATORE SI 24 24 E MIX
CARBURETTOR SI 24 24 E MIX

06000585 CARBURATORE SI 20 20 D MIX
CARBURETTOR SI 20 20 D MIX

06000586 CARBURATORE SI 24 24 E
CARBURETTOR SI 24 24 E

06000587 CARBURATORE SI 20 20 D
CARBURETTOR SI 20 20 D

06000617 CARBURATORE SI 26 26E MIX
CARBURETTOR SI 26 26E MIX

06000618 CARBURATORE SI 26 26G MIX
CARBURETTOR SI 26 26G MIX



06000753 CARBURATORE SHB 16 10
CARBURETTOR SHB 16 10

06000764 CARBURATORE SHB 16 16
CARBURETTOR SHB 16 16



06000834 CARBURATORE SHB 27 24
CARBURETTOR SHB 27 24

06000843 CARBURATORE SHB 22 17B
CARBURETTOR SHB 22 17B



06000879 CARBURATORE 16 16F
CARBURETTOR 16 16F

06000917 CARBURATORE SHB 16 10F
CARBURETTOR SHB 16 10F

06000926 CARBURATORE SHB 16 12M
CARBURETTOR SHB 16 12M

06000936 CARBURATORE SHB 16 12N
CARBURETTOR SHB 16 12N



06000959 CARBURATORE SHBB 22 22
CARBURETTOR SHBB 22 22



06000773 CARBURATORE SHBC 19 19
CARBURETTOR SHBC 19 19

06000896 CARBURATORE SHBC 18 16A
CARBURETTOR SHBC 18 16A

06000938 CARBURATORE SHBC 18 16N
CARBURETTOR SHBC 18 16N

06000958 CARBURATORE SHBC 18 16P
CARBURETTOR SHBC 18 16P



06009364 CARBURATORE VHST 28 BS
CARBURETTOR VHST 28 BS



06000866 CARBURATORE SHBC 19 19E
CARBURETTOR SHBC 19 19E

06000943 CARBURATORE SHBC 19 19E
CARBURETTOR SHBC 19 19E



06009303 CARBURATORE VHSH 30 CS
CARBURETTOR VHSH 30 CS



06009784 CARBURATORE VHSB 34 LD
CARBURETTOR VHSB 34 LD

Carburatori | Carburettors



- 06001515** CARBURATORE SHA 14 12L
CARBURETTOR SHA 14 12L
- 06001682** CARBURATORE SHA 14 14L
CARBURETTOR SHA 14 14L
- 06002013** CARBURATORE SHA 15 15G
CARBURETTOR SHA 15 15G
- 06002043** CARBURATORE SHA 15 15
CARBURETTOR SHA 15 15
- 06002151** CARBURATORE SHA 16 16
CARBURETTOR SHA 16 16
- 06002152** CARBURATORE SHA 16 16G
CARBURETTOR SHA 16 16G
- 06002183** CARBURATORE SHA 14 14L
CARBURETTOR SHA 14 14L



- 06002506** CARBURATORE PHBG 19 AS
CARBURETTOR PHBG 19 AS
- 06002557** CARBURATORE PHBG 21 AS
CARBURETTOR PHBG 21 AS
- 06002575** CARBURATORE PHBG 19 CS MIX
CARBURETTOR PHBG 19 CS MIX
- 06002633** CARBURATORE PHBG 21 CS MIX
CARBURETTOR PHBG 21 CS MIX
- 06002695** CARBURATORE PHBG 19 DS
MIX + DEPRESSORE
CARBURETTOR PHBG 19 DS
MIX + DEPRESSORE
- 06002696** CARBURATORE PHBG 21 DS
MIX + DEPRESSORE
CARBURETTOR PHBG 21 DS
MIX + DEPRESSORE
- 06002913** CARBURATORE PHBG 18 BS
CARBURETTOR PHBG 18 BS



- 06003046** CARBURATORE PHBN 12 HS
CARBURETTOR PHBN 12 HS
- 06003062** CARBURATORE PHBN 16 FS
CARBURETTOR PHBN 16 FS
- 06003067** CARBURATORE PHBN 17,5 LS
CARBURETTOR PHBN 17,5 LS
- 06003069** CARBURATORE PHBN 12 GS
CARBURETTOR PHBN 12 GS



- 06000785** CARBURATORE SHBC 19 19D
CARBURETTOR SHBC 19 19D



- 06001012** CARBURATORE PHVA 17 5 ED
CARBURETTOR PHVA 17 5 ED
- 06001389** CARBURATORE PHVA 17 5 TS
CARBURETTOR PHVA 17 5 TS
- 06001391** CARBURATORE PHVA 12 PS
CARBURETTOR PHVA 12 PS
- 06001438** CARBURATORE PHVA 17 5 US
CARBURETTOR PHVA 17 5 US
- 06008330** CARBURATORE PHVA 12 QD
CARBURETTOR PHVA 12 QD
- 06008348** CARBURATORE PHVA 12 QD
CARBURETTOR PHVA 12 QD
- 06008402** CARBURATORE PHVA 12 QD
CARBURETTOR PHVA 12 QD



- 06002715** CARBURATORE PHBL 24 AS
CARBURETTOR PHBL 24 AS
- 06002724** CARBURATORE PHBL 24 BS
CARBURETTOR PHBL 24 BS
- 06002731** CARBURATORE PHBL 25 BS
CARBURETTOR PHBL 25 BS
- 06002733** CARBURATORE PHBL 24 AD
CARBURETTOR PHBL 24 AD
- 06002762** CARBURATORE PHBL 24 BD MIX
CARBURETTOR PHBL 24 BD MIX
- 06002841** CARBURATORE PHBL 26 BS
CARBURETTOR PHBL 26 BS



- 06003302** CARBURATORE PHBH 28 BS
CARBURETTOR PHBH 28 BS
- 06003303** CARBURATORE PHBH 26 BS
CARBURETTOR PHBH 26 BS
- 06003343** CARBURATORE PHBH 30 BS
CARBURETTOR PHBH 30 BS

Ricambi | Spare parts



BUSTA GUARNIZIONI
GASKET KIT

09052526
09052533
09052537
09052540
09052541
09052543
09052553
09052555
09052612
09052620
09052621
09052622
09052625
09052627



KIT DISP. AVVIAM. AUTOM.
AUTOMATIC STARTER DEVICE

09053077
09053078
09053079
09053080
09053081
09053082



KIT AVVIAM. A FILO
CABLE STARTER KIT

09053002
09053003
09053004
09053005
09053008
09053009
09053011
09053130
09053141



KIT TUBETTO
TUBE KIT

09053036 90
09053037 70
09053038 50
09053039 40
09053073 32
09053074 50
09053075 70
09053129 VHST



09014872
09014985
09015059
COPERCHIO CAMERA MISC.
MIXTURE CHAMBER COVER



09053042
09053043
09053044
09053047

KIT PIPETTA
PIPE KIT



PIPETTA
PIPE

09003364
09006475
09006517
09008106
09009249
09009250
09010918



09003362
09006109
09006210

FILTRO BENZINA
FUEL FILTER



09053053

KIT GALLEGGIANTE
FLOAT KIT



09004567
09006122
09007420
09009450

GALLEGGIANTE
FLOAT



VASCHETTA
FLOAT CHAMBER

09009444
09013412
09013502
09013503
09013678
09014181
09014363
09014478
09014699
09015354
09015396
09015769



09002838

SPILLO CHIUS. BENZ.
FUEL NEEDLE



09004559

SPILLO CHIUS. BENZ.
FUEL NEEDLE



09008080

SPILLO CHIUS. BENZ. CON MOLLA
FUEL NEEDLE W/SPRING



09011668

SPILLO CHIUS. BENZ. CON MOLLA
FUEL NEEDLE W/SPRING



09012202

SPILLO CHIUS. BENZ. CON MOLLA
FUEL NEEDLE W/SPRING



09015360

SPILLO CHIUS. BENZ. CON MOLLA
FUEL NEEDLE W/SPRING



09008649

09009436

09010375

09016954

VALVOLA A SPILLO
NEEDLE VALVE



09009632

09010586

09010638

09012476

09014162

09014166

09015870

COPERCHIO VALVOLA
VALVE COVER

Ricambi | Spare parts



- 09001486** GETTO
MAIN JET
- 09053148** KIT GETTO 50-52-55-58-60-62-65-68-70-72
MAIN JET KIT 50-52-55-58-60-62-65-68-70-72
- 09053149** KIT GETTO 75-78-80-82-85-88-90-92-95-98
MAIN JET KIT 75-78-80-82-85-88-90-92-95-98
- 09053150** KIT GETTO 100-102-105-108-110-112-115-118-120-122
MAIN JET KIT 100-102-105-108-110-112-115-118-120-122



- 09006413** GETTO
MAIN JET
- 09053151** KIT GETTO 50-52-55-58-60-62-65-68-70-72
MAIN JET KIT 50-52-55-58-60-62-65-68-70-72
- 09053152** KIT GETTO 75-78-80-82-85-88-90-92-95-98
MAIN JET KIT 75-78-80-82-85-88-90-92-95-98
- 09053153** KIT GETTO 100-102-105-108-110-112-115-118-120-122
MAIN JET KIT 100-102-105-108-110-112-115-118-120-122
- 09053154** KIT GETTO 125-128-130-132-135-138-140-142-145-148
MAIN JET KIT 125-128-130-132-135-138-140-142-145-148



- 09004576** GETTO
MAIN JET
- 09053155** KIT GETTO 105-108-110-112-115-118-120-122-125-128
MAIN JET KIT 105-108-110-112-115-118-120-122-125-128



- 09053157** KIT GETTO
VARIABLE VHSH
VARIABLE JET KIT
VHSH



- 09005353** EMULSIONATORE BE
DIFFUSER BE
- 09009892** GETTO MINIMO SI
MINIMUM JET SI



- 09005827** CALIBRATORE
GAUGE



- 09009564** POLVERIZZATORE AQ
ATOMIZER AQ



- 09002265** SPILLO CONICO D
CONICAL NEEDLE D
- 09008530** SPILLO CONICO K
CONICAL NEEDLE K
- 09009477** SPILLO CONICO X
CONICAL NEEDLE X
- 09009595** SPILLO CONICO W
CONICAL NEEDLE W
- 09016250** SPILLO CONICO A
CONICAL NEEDLE A



- 09006108**
- 09006231**
- 09007405**
- 09009475**
- 09010569**
- 09013685**
- 09015362**
- 09016620**
- VALVOLA GAS
THROTTLE VALVE



- 09053022** KIT VITE REG. MISC. MIN.
IDLE MIX ADJ. SCREW KIT
- 09053029** KIT VITE REG. VALV. GAS
THROTTLE VALVE ADJ. SC
- 09053072** KIT VITE REG. VALV. GAS
THROTTLE VALVE ADJ. SC
- 09053086** KIT VITE REG. VALVOLA
THROTTLE VALVE ADJ. SC
- 09053090** KIT VITE REG. VALVOLA
THROTTLE VALVE ADJ. SC
- 09053091** KIT VITE REG. ARIA
AIR ADJ. SCREW KIT
- 09053119** KIT VITE REG. VALV. VHST
THROTTLE VALVE ADJ. SC VHST



VITE
SCREW

- 09003357**
- 09006140**
- 09007412**
- 09009517**
- 09011836**
- 09011837**
- 09013709**



KIT FASCETTA
CLAMP KIT

- 09053016**
- 09053017**
- 09053018**
- 09053020**
- 09053021**



- 09006117** ELEMENTO FILTRANTE
FILTER ELEMENT



RIDUZIONE ISOLANTE
INSULATING
REDUCTION

- 09004477**
- 09006448**
- 09007417**
- 09008376**
- 09010757**
- 09010811**
- 09011362**



MOLLA
SPRING

- 09003346**
- 09003606**
- 09005951**
- 09006455**
- 09007413**
- 09009336**



Tutto quello che ami...

La storia delle Vespa truccate raccontata da Andrea Pinasco in un libro dedicato a tutti gli appassionati, i giovani che vogliono conoscere la storia e le imprese di

un marchio che è entrato nella leggenda delle preparazioni, e i meno giovani che vogliono ripercorrere i ricordi di un'epoca passata ma mai tramontata.

Il libro "QUELLI DELLE VESPA TRUCCATE" è una raccolta di fotografie e aneddoti dedicati al mondo della Vespa con la prefazione del mitico Carlo Perelli, per anni direttore responsabile della rivista Motociclismo, oggi direttore di Motociclismo d'Epoca; un libro che non può mancare nella raccolta personale dedicata alla Vespa.

The history of the tuned Vespa shared by Andrea Pinasco in a book dedicated to the fans, young people who want to learn the history and ventures of a brand that has become a legend of tuning, and the

older ones who want to retrace the memories of a bygone era but never waned. The book "THOSE OF VESPA TUNING" is a collection of photographs and stories dedicated to the world of Vespa with a preface by the legendary Carlo Perelli, for many years editor of "Motociclismo" now director of "Motociclismo d'Epoca", a book that cannot be lacking in your personal collection dedicated to Vespa.

Andrea Pinasco
**Quelli
delle Vespa truccate**

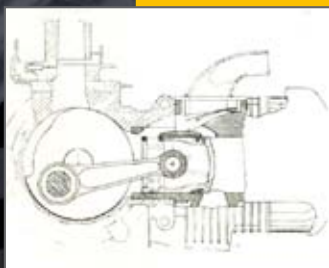
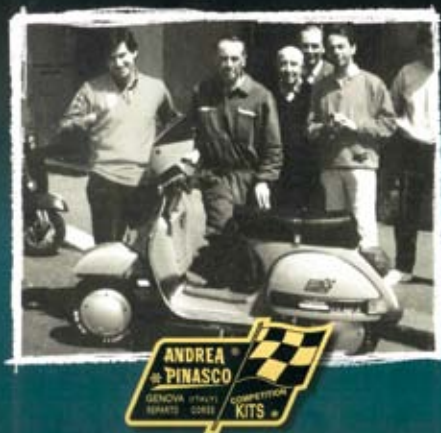

su PINASCOSTORE

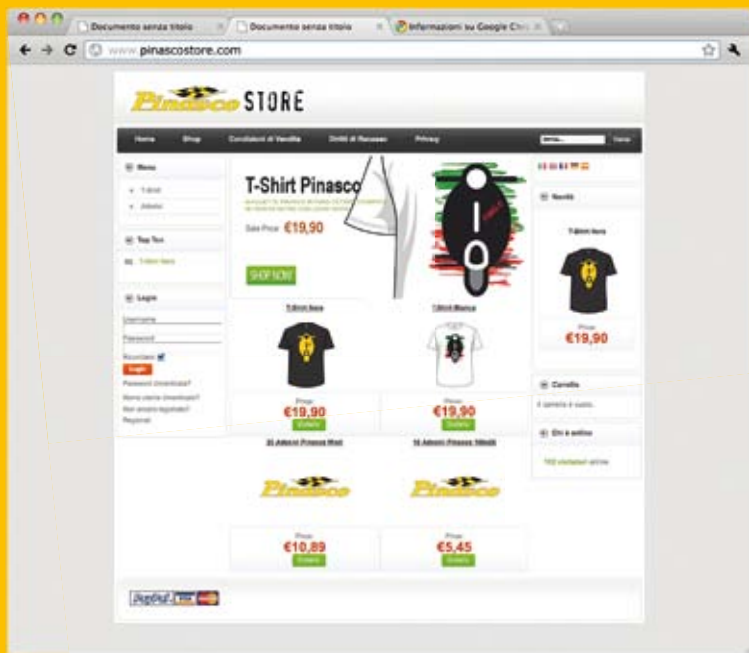

Sul sito www.pinascostore.com puoi acquistare i gadget Pinasco originali.

Il libro "Quelli delle vespe truccate" con la raccolta di aneddoti e fotografie dedicati al mondo della vespa.

Le T-Shirt Pinasco sono realizzate in puro cotone nei colori bianco o nero e stampate in fronte e retro con i loghi Vespa.

Il set di adesivi Pinasco in PVC resistenti all'acqua e alla luce.

On the web site www.pinascostore.com you can buy original gadgets Pinasco.

The book "Quelli delle Vespa Truccate" is a collection of stories and pictures dedicated to the world of Vespa.

T-Shirt Pinasco made of pure cotton in black and white and printed logos Pinasco in double-sided.

Set of stickers Pinasco PVC, water and UV rays resistant.

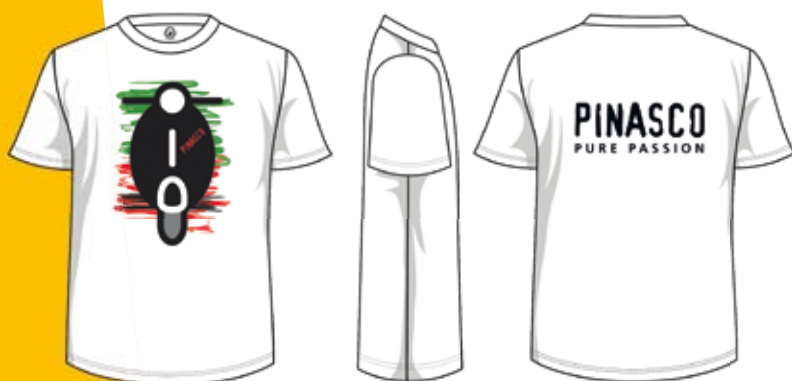

www.pinascostore.com



Pinasco[®]
PURE PASSION

ITALY

tel. +39 049 767472
fax +39 049 8847722

www.pinasco.com